



euro3plast

made in italy



**KHILIA** collection 2015



# khilia collection 2015

---

collection	p.	2
special colors	p.	52
mini	p.	58
gloss	p.	72
laccati • lacquered	p.	82
lights	p.	88
mini lights	p.	116
accessori • accessories	p.	132
utilizzo • suggestions	p.	136
avvertenze • warnings	p.	144
merchandising tools	p.	146
dati tecnici • technical data	p.	157
colors	p.	210

# khilia collection

---

Pratici, eleganti e rispettosi dell'ambiente, arredano sia gli ambienti esterni che quelli interni creando angoli dall'effetto suggestivo. Sono tutti realizzati con resine termoplastiche (PE) resistenti agli urti, agli agenti atmosferici (-65°, +85°), ai raggi U.V. e sono interamente riciclabili.

These practical and elegant products are environmentally friendly that look good both indoors and out, helping to create attractive and picturesque features. All are made from polyethylene (PE) resin and so offer maximum resistance to shocks, atmospheric agents (-65°to +85°), UV rays and are completely recyclable.

Praktisch, elegant und umweltbewusst, richten sie sowohl Außenbereiche als auch Innenräume ein und schaffen dabei Ecken mit faszinierenden Effekten. Sie bestehen allesamt aus schlagfesten, wetterfesten (-65°, +85°) und gegenüber von UV – Strahlen beständigen Thermoplast - Harzen (PE) und sind vollständig recyclingfähig.

Prácticos, elegantes y respetuosos del medioambiente, decoran los ambientes exteriores e interiores creando rincones con efectos sugestivos. Todos realizados con resinas termoplásticas (PE) y resistentes a los golpes, a los agentes atmosféricos (-65°, +85°) y a los rayos UV. Además, todos los productos son íntegramente reciclables.

Pratiques, élégants et respectueux de l'environnement. Conçus pour l'ameublement des grands espaces, tant à l'extérieur qu'à l'intérieur, où ils créent des angles aux effets évocateurs. Tous les articles sont réalisés en résines thermoplastiques (PE) résistant aux chocs, aux agents atmosphériques (-65°, +85°) et aux rayons U.V. et ils sont entièrement recyclables.



100%  
Recyclable



Lightweight



Antishock



U.V.  
Resistant



-65°C  
+85°C  
Resistant

---

# index

---

<b>akan</b> cassetta	p. 26
<b>akan</b> vaso	p. 27
<b>etria</b>	p. 16
<b>icle</b>	p. 30
<b>ikon</b>	p. 6
<b>ilie</b>	p. 10
<b>kiam</b>	p. 12
<b>kube</b> cassetta	p. 34
<b>kube</b> vaso	p. 32
<b>kube</b> panca	p. 50
<b>kube</b> sgabello	p. 51
<b>kube high</b> cassetta alta	p. 39
<b>kube high</b> vaso alto	p. 38
<b>kube high slim</b> cassetta alta	p. 43
<b>kube high slim</b> vaso alto	p. 42
<b>kube high slim</b> modulo	p. 46
<b>kube tower</b> cassetta	p. 49
<b>kube tower</b> vaso	p. 48
<b>misia</b>	p. 31
<b>niscal</b>	p. 24
<b>opus</b>	p. 28
<b>quadrum</b>	p. 15
<b>tulum</b>	p. 14





ikon



ikon

vaso • pot  
pflanzkübel • maceta • pot

art. 2603 ø 40 (cm. 40 x 36 h.) lt. 23

art. 2604 ø 50 (cm. 50 x 44 h.) lt. 47

art. 2605 ø 60 (cm. 60 x 53 h.) lt. 82

art. 2896 ø 70 (cm. 70 x 62 h.) lt. 130

art. 2541 ø 80 (cm. 80 x 71 h.) lt. 202

art. 2542 ø 100 (cm. 100 x 89 h.) lt. 398

art. 2543 ø 120 (cm. 120 x 107 h.) lt. 680

art. 2786 ø 140 (cm. 140 x 125 h.) lt. 1066

art. 2787 ø 160 (cm. 160 x 143 h.) lt. 1594

C2

G9

87

86

D7

E5





## ikon

sottovaso • saucer  
untersetzer • plato • soucoupe

art. 2606 Ø **40** (cm.29 x 3 h.)

art. 2607 Ø **50** (cm.36 x 3,5h.)

art. 2608 Ø **60** (cm.42,5x4 h.)

art. 2897 Ø **70** (cm.50,5x 4,5h.)

art. 2598 Ø **80** (cm.56 x 5 h.)

art. 2599 Ø **100** (cm. 71 x 6 h.)

art. 2600 Ø **120** (cm. 85 x 7 h.)

art. 2814 Ø **140** (cm. 99x8,5h.)

art. 2815 Ø **160** (cm.113x9,5h.)

# ikon



## ikon

vaso • pot  
pflanzkübel • maceta • pot

art. 2603 Ø 40 (cm. 40 x 36 h.) lt. 23

art. 2604 Ø 50 (cm. 50 x 44 h.) lt. 47

art. 2605 Ø 60 (cm. 60 x 53 h.) lt. 82

art. 2896 Ø 70 (cm. 70 x 62 h.) lt. 130

art. 2541 Ø 80 (cm. 80 x 71 h.) lt. 202

art. 2542 Ø 100 (cm. 100 x 89 h.) lt. 398

art. 2543 Ø 120 (cm. 120 x 107 h.) lt. 680

art. 2786 Ø 140 (cm. 140 x 125 h.) lt. 1066

art. 2787 Ø 160 (cm. 160 x 143 h.) lt. 1594



## ikon

sottovaso • saucer  
untersetzer • plato • soucoupe

art. 2606 Ø 40 (cm.29 x 3 h.)

art. 2607 Ø 50 (cm.36 x 3,5h.)

art. 2608 Ø 60 (cm.42,5x 4 h.)

art. 2897 Ø 70 (cm.50,5x 4,5h.)

art. 2598 Ø 80 (cm.56 x 5 h.)

art. 2599 Ø 100 (cm. 71 x 6 h.)

art. 2600 Ø 120 (cm. 85 x 7 h.)

art. 2814 Ø 140 (cm. 99x8,5h.)

art. 2815 Ø 160 (cm.113x9,5h.)

# ilie



## ilie

vaso • pot  
pflanzkübel • maceta • pot

art. 2497 ø 37 (cm. 37 x 75 h.) lt. 13

art. 2498 ø 42 (cm. 42 x 90 h.) lt. 19

art. 2415 ø 47 (cm. 47 x 98 h.) lt. 26

art. 2506 ø 57 (cm. 57 x 126 h.) lt. 54

## kit riserva d'acqua

water reserve kit • wasserreservoir kit  
kit reserva de agua • kit réserve d'eau

art. A4256 ø 20 kit riserva d'acqua lt. 1,3

art. A4239 ø 25 kit riserva d'acqua lt. 2,5

art. A4240 ø 32 kit riserva d'acqua lt. 4

C2

87

86

E5

C1



# kiam



## kiam

vaso quadro • square pot  
pflanzkübel quadratisch • maceta cuadrada • pot carré

art. 2499 cm. **35** (cm. 35 x 35 x 75 h.) lt. 13

art. 2500 cm. **40** (cm. 40 x 40 x 90 h.) lt. 20

C2

87

86

E5

C1



# tulum



## tulum

vaso • pot  
pflanzkübel • maceta • pot

art. 2373 ø 35 (cm. 35 x 51 h.) lt. 18

art. 2374 ø 43 (cm. 43 x 63 h.) lt. 33

art. 2375 ø 56 (cm. 56 x 102 h.) lt. 91



# quadrum



## quadrum

vaso quadro • square pot  
pflanzkübel quadratisch • maceta cuadrada • pot carré

art. 2419 cm. **37** (cm. 37x37x 73h.) lt. 16

art. 2420 cm. **51** (cm. 51x51x100h.) lt. 41

# etria



## etria

vaso con doppia parete • pot with double wall  
pflanzkübel doppelwandig • maceta con doble pared • pot avec double paroi

art. 2903 ø 18 (cm. 18x14,5 h.) lt. 1,8

art. 2453 ø 24 (cm. 24x20 h.) lt. 5

art. 2318 ø 34 (cm. 34x28 h.) lt. 14

art. 2319 ø 44 (cm. 44x36 h.) lt. 30

art. 2320 ø 54 (cm. 54 x 44 h.) lt. 56

art. 2447 ø 64 (cm. 64 x 52 h.) lt. 86

art. 2454 ø 74 (cm. 74 x 61 h.) lt. 131

C2

G9

87

86

E5

# etria uno



## etria uno

vaso • pot  
pflanzkübel • maceta • pot

art. 2904 ø 18 (cm. 18x14,5 h.) lt. 2,4

art. 2860 ø 24 (cm. 24x20 h.) lt. 6

art. 2861 ø 34 (cm. 34x28 h.) lt. 18

art. 2862 ø 44 (cm. 44x36 h.) lt. 39

art. 2863 ø 54 (cm. 54 x 44 h.) lt. 73

art. 2864 ø 64 (cm. 64 x 52 h.) lt. 123

art. 2865 ø 74 (cm. 74 x 61 h.) lt. 192

C2

G9

87

86

E5

# pastel colors

---







etria

etria

vaso con doppia parete • pot with double wall  
pflanzkübel doppelwandig • maceta con doble pared • pot avec double paroi

art. 2903 ø 18 (cm. 18x14,5 h.) lt. 1,8

art. 2453 ø 24 (cm. 24x20 h.) lt. 5

art. 2318 ø 34 (cm. 34x28 h.) lt. 14

art. 2319 ø 44 (cm. 44x36 h.) lt. 30

art. 2320 ø 54 (cm. 54 x 44 h.) lt. 56

art. 2447 ø 64 (cm. 64 x 52 h.) lt. 86

art. 2454 ø 74 (cm. 74 x 61 h.) lt. 131

M9

N1

L4

N2

NO

69

# etria uno



## etria uno

vaso • pot  
pflanzkübel • maceta • pot

art. 2904 ø 18 (cm. 18x14,5 h.) lt. 2,4

art. 2860 ø 24 (cm. 24x20 h.) lt. 6

art. 2861 ø 34 (cm. 34x28 h.) lt. 18

art. 2862 ø 44 (cm. 44x36 h.) lt. 39

art. 2863 ø 54 (cm. 54 x 44 h.) lt. 73

art. 2864 ø 64 (cm. 64 x 52 h.) lt. 123

art. 2865 ø 74 (cm. 74 x 61 h.) lt. 192

M9

N1

L4

N2

NO

69







# niscal



## niscal

vaso • pot  
pflanzkübel • maceta • pot

art. 2496 ø 37 (cm. 37 x 34 h.) lt. 12

art. 2484 ø 47 (cm. 47 x 43 h.) lt. 25

art. 2485 ø 57 (cm. 57 x 53 h.) lt. 45

87

86

E5

C1

69



# akan cassetta

---



akan

cassetta • plant box  
pflanzkasten • jardinera • jardinière

art. 2465 cm. 80 (cm. 80x40x 33h.) lt. 60

---

# akan vaso

---



## akan

vaso quadro • square pot  
pflanzkübel quadratisch • maceta cuadrada • pot carré

art. 2486 cm. **40** (cm. 40x40x 33h.) It. 25

art. 2494 cm. **50** (cm. 50x50x42h.) It. 51

---



opus

**opus**

vaso • pot  
pflanzkübel • maceta • pot

art. 2495 ø 37 (cm. 37 x 34 h.) lt. 14

art. 2482 ø 47 (cm. 47 x 43 h.) lt. 26

art. 2483 ø 57 (cm. 57 x 53 h.) lt. 47



# icle

---



---

## icle

vaso • pot  
pflanzkübel • maceta • pot

---

art. 2390 cm. **100** (cm. 19 x 98 h.)

---

art. 2391 cm. **120** (cm. 20 x 117 h.)

---



# misia



## misia

vaso • pot  
pflanzkübel • maceta • pot

art. 2461 ø 30 (cm. 30 x 24 h.) lt. 4

art. 2416 ø 40 (cm. 40 x 32 h.) lt. 12

art. 2417 ø 50 (cm. 50 x 40 h.) lt. 19

art. 2418 ø 60 (cm. 60 x 48 h.) lt. 43

art. 2445 ø 70 (cm. 70 x 56 h.) lt. 69

art. 2446 ø 80 (cm. 80 x 64 h.) lt. 103

art. 2460 ø 90 (cm. 90 x 72 h.) lt. 147

# kube vaso



## kube

vaso • pot  
pflanzkübel • maceta • pot

art. 2538 cm. **30** (cm. 30 x 30 x 30 h.) lt. 9  
art. 2514 cm. **40** (cm. 40 x 40 x 40 h.) lt. 22  
art. 2515 cm. **50** (cm. 50 x 50 x 50 h.) lt. 45

## kube

con ruote • with rollers  
mit rollen • con ruedas • avec roues

art. 2587 cm. **30** (cm. 30 x 30 x 31 h.) lt. 9  
art. 2588 cm. **40** (cm. 40 x 40 x 41 h.) lt. 22  
art. 2589 cm. **50** (cm. 50 x 50 x 51 h.) lt. 45

## kit riserva d'acqua

water reserve kit • wasserreservoir kit  
kit reserva de agua • kit réserve d'eau

art. A4255 cm. **17** kit riserva d'acqua lt. 1,2  
art. A4241 cm. **24** kit riserva d'acqua lt. 3  
art. A4242 cm. **30** kit riserva d'acqua lt. 5



# kube cassetta



## kube

cassetta • plant box  
pflanzkasten • jardineria • jardinière

art. 2601 cm. **80** (cm. 80x30x30h.) lt. 32

art. 2548 cm. **100** (cm. 100x40x40h.) lt. 73

## kube

con ruote • with rollers  
mit rollen • con ruedas • avec roues

art. 2753 cm. **80** (cm. 80x30x31h.) lt. 32

art. 2590 cm. **100** (cm. 100x40x41h.) lt. 73

## kit riserva d'acqua

water reserve kit • wasserreservoir kit  
kit reserva de agua • kit réserve d'eau

art. A4327 cm. **17** kit riserva d'acqua lt. 3,6

art. A4278 cm. **24** kit riserva d'acqua lt. 9







# kube high vaso alto



## kube high

vaso alto • high pot  
pflanzsäule • maceta alta • pot haut

art. 2611 cm. **30** (cm. 30 x 30 x 70 h.) lt. 9

art. 2612 cm. **40** (cm. 40 x 40 x 70 h.) lt. 23

## kube high

con ruote • with rollers  
mit rollen • con ruedas • avec roues

art. 2733 cm. **30** (cm. 30 x 30 x 71 h.) lt. 9

art. 2734 cm. **40** (cm. 40 x 40 x 71 h.) lt. 23

## kit riserva d'acqua

water reserve kit • wasserreservoir kit  
kit reserva de agua • kit réserve d'eau

art. A4255 cm. **17** kit riserva d'acqua lt. 1,2

art. A4241 cm. **24** kit riserva d'acqua lt. 3



# kube high cassetta alta



## kube high

cassetta alta • high plant box  
hoher pflanzkasten • jardinera alta • jardinière haute

art. 2602 cm. **80** (cm. 80x30x70 h.) lt. 32

art. 2586 cm. **100** (cm. 100x40x70 h.) lt. 77,5

## kube high

con ruote • with rollers  
mit rollen • con ruedas • avec roues

art. 2754 cm. **80** (cm. 80x30x71 h.) lt. 32

art. 2591 cm. **100** (cm. 100x40x71 h.) lt. 77,5

## kit riserva d'acqua

water reserve kit • wasserreservoir kit  
kit reserva de agua • kit réserve d'eau

art. A4327 cm. **17** kit riserva d'acqua lt. 3,6

art. A4278 cm. **24** kit riserva d'acqua lt. 9





# kube high slim vaso alto



## kuba high slim

vaso alto • high pot  
pflanzsäule • maceta alta • pot haut

art. 2788 cm. 25 (cm. 25x25x70 h.) lt. 8,8

## kit riserva d'acqua

water reserve kit • wasserreservoir kit  
kit riserva de agua • kit réserve d'eau

art. A4255 cm. 17 kit riserva d'acqua lt. 1,2

C2

G9

87

86

A2

43

A9

E5

# kube high slim cassetta alta



## kube high slim

cassetta alta • high plant box  
hoher pflanzkasten • jardineria alta • jardinière haute

art. 2777 cm. 80 (cm. 80x25x70 h.) lt. 32

## kit riserva d'acqua

water reserve kit • wasserreservoir kit  
kit reserva de agua • kit réserve d'eau

art. A4327 cm. 17 kit riserva d'acqua lt. 3,6





# kube high slim modulo



## kube high slim

modulo • module  
modul • módulo • module

art. 2790 cm. 25 (cm. 25x25x70 h.)

art. 2789 cm. 80 (cm. 80x25x70 h.)







# kube tower vaso alto



## kube tower

vaso alto • high pot  
pflanzsäule • maceta alta • pot haut

art. 2826 cm. 30 (cm.30x30x90h.) lt. 10

## kit riserva d'acqua

water reserve kit • wasserreservoir kit  
kit reserva de agua • kit réserve d'eau

art. A4255 cm. 17 kit riserva d'acqua lt. 1,2

C2

G9

87

E5

# kube tower cassetta alta



## kube tower

cassetta alta • high plant box  
hoher pflanzkasten • jardinera alta • jardinière haute

art. 2825 cm. 70 (cm. 70 x 30 x 90 h.) lt. 29

## kit riserva d'acqua

water reserve kit • wasserreservoir kit  
kit riserva de agua • kit réserve d'eau

art. A4327 cm. 17 kit riserva d'acqua lt. 3,6

C2

G9

87

E5

# kube panca

---



## kube

panca • bench  
bank • banco • banc

art. 2549 cm. 100 (cm.100x40x40h.)

C2

87

86

E5

# kube sgabello



## kube

sgabello • stool  
hocker • taburete • tabouret

art. 2532 cm. 40 (cm. 40x40x40h.)

art. 2533 cm. 50 (cm. 50x50x50h.)



# khilia special colors

---

Caratterizzato da tonalità intense: i prodotti assumono un'anima industriale e mantenendo una base nera si vestono di tonalità come l'arancio e il verde.

Characterized by intense shades: the products take on an industrial soul; and while keeping a black base, they are dressed in hues such as orange and green.

Bezeichnend sind kräftige Farbtöne: Das Motto der Artikel wird industrial und, indem der schwarze Grund beibehalten wird, nehmen sie dabei Farben wie orange und grün an.

Caracterizado por tonalidades intensas: los productos adquieren un alma industrial y, manteniendo una base negra, se embellecen con coloraciones como el naranja y el verde.

Les produits s'agrémentent de couleurs vives ! Tout en conservant leur caractère industriel et leur base noire, ils s'habillent de teintes telles que l'orange et le vert.

# index

---

<b>kube</b> panca	p.	57
<b>kube</b> sgabello	p.	57
<b>kube high</b> cassetta alta	p.	56
<b>kube high</b> vaso alto	p.	56
<b>kube tower</b> cassetta alta	p.	56
<b>kube tower</b> vaso alto	p.	56

# special colors







# kube



## kube high

cassetta alta • high plant box  
hoher pflanzkasten • jardinera alta • jardinière haute

art. 2602 cm. 80 (cm. 80x30x70h.) lt. 32

## kube high

vaso alto • high pot  
pflanzsäule • maceta alta • pot haut

art. 2611 cm. 30 (cm.30x30x70h.) lt. 9

## kube tower

cassetta alta • high plant box  
hoher pflanzkasten • jardinera alta • jardinière haute

art. 2825 cm. 70 (cm. 70 x 30 x 90 h.) lt. 29

## kube tower

vaso alto • high pot  
pflanzsäule • maceta alta • pot haut

art. 2826 cm. 30 (cm.30x30x90h.) lt. 10

kube



kube

panca • bench  
bank • banco • banc

art. 2549 cm. 100 (cm.100x40x40h.)

kube

sgabello • stool  
hocker • taburete • tabouret

art. 2532 cm. 40 (cm.40x40x40h.)

# khilia mini

---

Piccoli vasi colorati, da disporre in contesti sia indoor che outdoor, capaci di arredare tavoli, scrivanie, davanzali di ambienti pubblici o privati. Questa linea propone gli stessi materiali e la stessa qualità di tutti i vasi Khilia collection, in un formato ridotto.

Small coloured pots for indoor or outdoor settings to enhance tables, desks, window sills in private or public spaces. This product line proposes the same materials and quality as the pots in the Khilia collection, but in smaller sizes.

Kleine bunte Kübel für den Innen und Außen als Tisch-, Schreibtisch- oder Fensterbankdekoration privat oder in Gesellschaftsräumen. Die Artikel dieser Serie werden aus demselben, hochwertigen Material und derselben Qualität wie die Produkte der Khilia collection hergestellt – sie sind nur kleiner!

Pequeñas macetas de colores de interior y exterior, para decorar mesas, escritorios, ventanas, en ambientes públicos o privados. Esta línea ofrece los mismos materiales y la misma calidad de toda la colección de macetas Khilia, en un formato reducido.

Petits pots colorés, à installer soit à l'intérieur soit à l'extérieur, décoration de tables, bureaux, halls d'entrée des lieux publics et privés. Cette ligne de produits apporte la même qualité et est composée des mêmes matériaux que l'ensemble des pots Khilia collection, dans un format réduit.

# index

---

<b>mini ikon</b>	p.	62
<b>mini kube</b> vaso	p.	64
<b>mini kube</b> cassetta	p.	66
<b>mini kube</b> con riserva d'acqua	p.	68
<b>mini kube</b> vaso con riserva d'acqua	p.	70
<b>mini kube</b> cassetta con riserva d'acqua	p.	70
<b>portacassetta</b>	p.	70





# mini ikon



## mini ikon

vaso • pot  
pflanzkübel • maceta • pot

art. 2635 ø 20 (cm. 20x17,5 h.) lt. 1,7

C2

G9

86

A2

43

A9





# mini kube vaso

---



---

## mini kube

vaso • pot  
pflanzkübel • maceta • pot

art. 2827 cm. 18 (cm. 18 x 18 x 18 h.) lt. 2,7

art. 2634 cm. 20 (cm. 20 x 20 x 20 h.) lt. 2,7

---

C2

G9

86

A2

43

A9



# mini kube cassetta



## mini kube

cassetta • plant box  
pflanzkasten • jardineria • jardinière

art. 2828 cm. 50 (cm. 50 x 18 x 18 h.) lt. 9

art. 2776 cm. 60 (cm. 60 x 20 x 20 h.) lt. 11,5

## portacassetta

bracket • halter  
portajardineria • accroche

art. A4415 cm. 50 (cm. 52x26x26,5h.)

C2

G9

86

A2

43

A9



# mini kube con riserva d'acqua

---





**cestino riserva acqua**  
water reserve basket  
korb für wasserreservoir  
cesta reserva de agua  
panier réserve d'eau



**indicatore del livello dell'acqua**  
water level indicator  
wasserstandsanzeiger  
indicator del nivel de agua  
indicateur de niveau d'eau



**argilla espansa**  
expanded clay  
blähton  
arcilla expandida  
argile expansée

## indoor:

## outdoor:

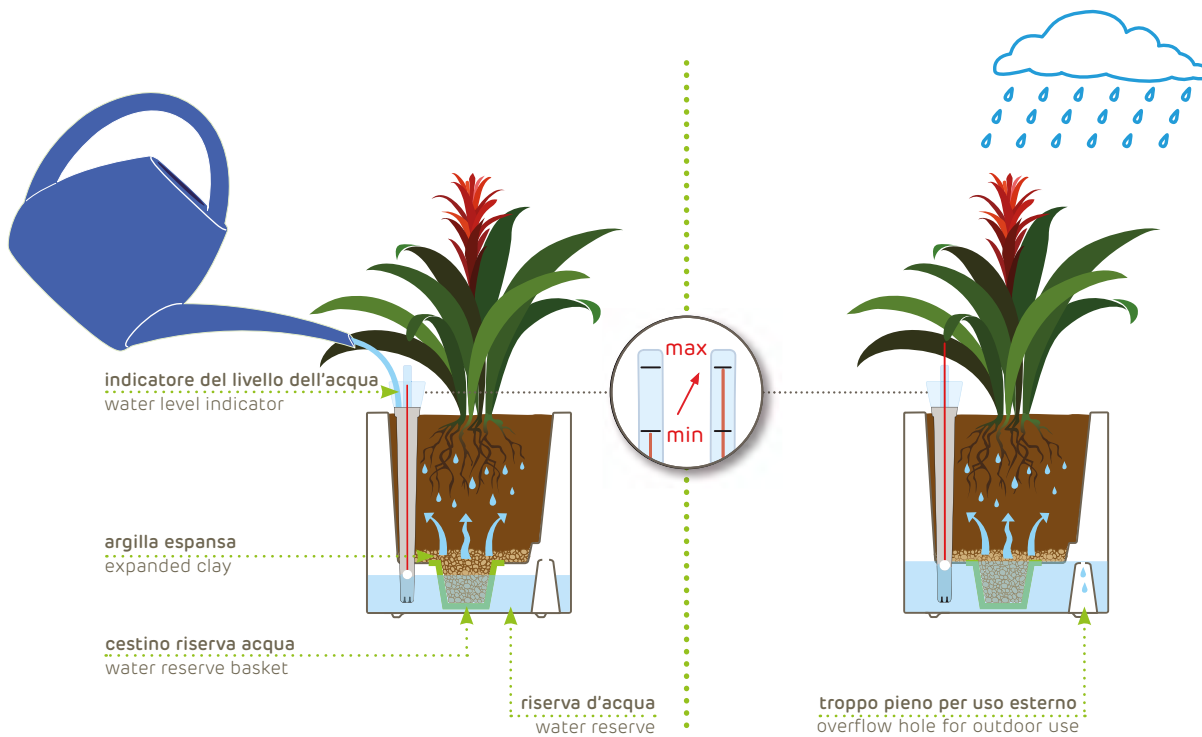

# mini kube con riserva d'acqua



## mini kube

vaso con riserva d'acqua  
pot with water reserve  
pflanzkübel mit wasserreservoir  
maceta con reserva de agua  
pot avec réserve d'eau

art. 2853 cm. **18** (cm. 18x18x18 h.)

riserva d'acqua lt. 1 • water reserve lt. 1

## mini kube

cassetta con riserva d'acqua  
plant box with water reserve  
pflanzkasten mit wasserreservoir  
jardinera con reserva de agua  
jardinière avec réserve d'eau

art. 2852 cm. **50** (cm. 50x18x18 h.)

riserva d'acqua lt. 3 • water reserve lt. 3

## portacassetta

bracket • halter  
portajardinera • accroche

art. A4415 cm. **50** (cm. 52x26x26,5h.)

C2

G9

86

A2

43

A9





# khilia gloss

---

Superfici lucide e colori cangianti sono le caratteristiche di questa nuova linea dal tratto giovane ma deciso.

I vasi Khilia gloss non subiscono nessun successivo processo di verniciatura, vengono prodotti direttamente nella versione lucida e colorata, pronti per arredare con la loro personalità ogni tipologia di ambiente.

Glossy surfaces and sparkling colours are the outstanding features of this new line with a young yet strong appeal.

The Khilia gloss pots do not undergo any further glazing processes as they are produced directly in the glossy coloured version ready to decorate all possible settings with their unique personality.

Glänzende Oberflächen und anziehende Farben zeichnen diese junge, klare Linie aus.

Die Khilia-gloss Serie ist nicht zusätzlich lackiert sondern wird sofort in dieser glänzenden durchgefärbten Version hergestellt - ein Blickpunkt in jeder Einrichtung.

Superficies brillantes y de colores cambiantes son la característica de ésta nueva línea joven seleccionada. El vaso Khilia gloss no experimenta ningún proceso sucesivo de lacado pero son producidos directamente en la versión lacada y coloreada, listos para diseñar con otra personalidad cualquier tipo de ambiente.

Surfaces brillantes et couleurs chatoyantes sont les caractéristiques de cette nouvelle ligne au trait jeune mais précis.

Les vases Khilia gloss ne subissent aucun processus de laquage mais sont fabriqués directement dans leur version brillante et colorée, prêts à meubler avec leur personnalité tous types de pièce.

# index

---

<b>ilie</b> vaso gloss	p. 76
<b>kiam</b> vaso quadro gloss	p. 77
<b>kube</b> vaso gloss	p. 74
<b>kuno</b> vaso gloss	p. 78
<b>misia</b> vaso gloss	p. 75

# kube



## kube

vaso gloss • gloss pot  
pflanzkübel gloss • maceta gloss • pot gloss

art. 2583 cm. 30 (cm. 30 x 30 x 30 h.) lt. 9

art. 2584 cm. 40 (cm. 40 x 40 x 40 h.) lt. 22

art. 2585 cm. 50 (cm. 50 x 50 x 50 h.) lt. 45

## kube

con ruote • with rollers  
mit rollen • con ruedas • avec roues

art. 2592 cm. 30 (cm. 30 x 30 x 31 h.) lt. 9

art. 2593 cm. 40 (cm. 40 x 40 x 41 h.) lt. 22

art. 2594 cm. 50 (cm. 50 x 50 x 51 h.) lt. 45

## kit riserva d'acqua

water reserve kit • wasserreservoir kit  
kit reserva de agua • kit réserve d'eau

art. A4255 cm. 17 kit riserva d'acqua lt. 1,2

art. A4241 cm. 24 kit riserva d'acqua lt. 3

art. A4242 cm. 30 kit riserva d'acqua lt. 5

# misia



## misia

vaso gloss • gloss pot

pflanzkübel gloss • maceta gloss • pot gloss

art. 2464 Ø 40 (cm. 40 x 32 h.) lt. 12

art. 2487 Ø 50 (cm. 50 x 40 h.) lt. 19

art. 2488 Ø 60 (cm. 60 x 48 h.) lt. 43



ilie

## ilie

vaso gloss • gloss pot  
pflanzkübel gloss • maceta gloss • pot gloss

art. 2640 ø 27 (cm. 27 x 56 h.) lt. 5

art. 2579 ø 32 (cm. 32 x 67 h.) lt. 9

art. 2509 ø 37 (cm. 37 x 75 h.) lt. 13

art. 2518 ø 47 (cm. 47 x 98 h.) lt. 26

art. 2580 ø 57 (cm. 57 x 126 h.) lt. 54

## kit riserva d'acqua

water reserve kit • wasserreservoir kit  
kit reserva de agua • kit réserve d'eau

art. A4256 ø 20 kit riserva d'acqua lt. 1,3

art. A4239 ø 25 kit riserva d'acqua lt. 2,5

art. A4240 ø 32 kit riserva d'acqua lt. 4

C2

86

88

G8

D7

E5

# kiam



## kiam

vaso quadro gloss • gloss square pot  
pflanzkübel quadratisch gloss • maceta cuadrada gloss • pot carré gloss

art. 2637 cm. **25** (cm. 25 x 25 x 56 h.) lt. 4,5

art. 2581 cm. **30** (cm. 30 x 30 x 67 h.) lt. 9

art. 2638 cm. **35** (cm. 35 x 35 x 75 h.) lt. 14

art. 2582 cm. **40** (cm. 40 x 40 x 90 h.) lt. 23

## kit riserva d'acqua

water reserve kit • wasserreservoir kit  
kit reserva de agua • kit réserve d'eau

art. A4255 cm. **17** kit riserva d'acqua lt. 1,2

art. A4373 cm. **17** kit riserva d'acqua lt. 1,2

art. A4241 cm. **24** kit riserva d'acqua lt. 3

# kuno



## kuno

vaso gloss • gloss pot  
pflanzkübel gloss • maceta gloss • pot gloss

art. 2536 ø 40 (cm. 40 x 40 h.) lt. 14

art. 2534 ø 50 (cm. 50 x 50 h.) lt. 28

art. 2535 ø 60 (cm. 60 x 60 h.) lt. 52

## kit riserva d'acqua

water reserve kit • wasserreservoir kit  
kit riserva de agua • kit réserve d'eau

art. A4256 ø 20 kit riserva d'acqua lt. 1,3

art. A4239 ø 25 kit riserva d'acqua lt. 2,5

art. A4240 ø 32 kit riserva d'acqua lt. 4









# khilia laccati • lacquered

---

Una collezione dove il colore è protagonista.

Sottoposti a un elaborato processo di laccatura che assicura un risultato perfetto e duraturo nel tempo, i vasi Khilia rispondono alle esigenze di una clientela che ricerca complementi versatili e contemporanei caratterizzati dalla forza del colore e dalla potenza espressiva della finitura laccata, esclusiva e preziosa.

Colour plays a major role in this collection.

Khilia pots undergo a complex lacquered process that guarantees a perfect, long-lasting finish. Khilia pots meet the demands of customers seeking versatile, contemporary furnishing objects characterised by the force of their lacquered colour and the expressive power of their exclusive unique finish.

Die Kollektion, in der die Farbe die Hauptrolle spielt.

Diese Khilia Artikel, die eine Speziallackierung haben, die Perfektion und Dauerhaftigkeit garantiert, sind die Antwort auf die Nachfrage der Kunden, die andersartige Artikel suchen, die sich gleichzeitig durch tolle Farben ausdrucksstark charakterisieren und sich andererseits durch die Speziallackierung exklusiv und wertvoll darstellen.

Una colección donde el color es el protagonista.

Debido a un elaborado proceso de lacado que asegura un resultado perfecto y duradero en el tiempo, la maceta Khilia responde a la exigencia de una clientela que busca complementos versátiles y contemporáneos caracterizados por la fuerza del color y de la potencia expresiva del acabado lacado, exclusivo y elegante.

Une collection où la couleur est reine.

Soumis à un processus de laquage élaboré qui assure un résultat parfait et durable dans le temps, les vases Khilia Laqués répondent aux exigences d'une clientèle qui recherche des éléments éclectiques et contemporains caractérisés par la force de la couleur et la puissance exprimée par la finition laquée, exclusive et précieuse.

# index

---

**ilie** vaso laccato p. 84

**ikon** vaso laccato p. 86

**quadrum** vaso quadro laccato p. 85

# ilie



## ilie

vaso laccato • lacquered pot  
pflanzkübel lackiert • maceta lacada • pot laqué

art. L2497 ø 37 (cm. 37 x 75 h.) lt. 13

art. L2498 ø 42 (cm. 42 x 90 h.) lt. 19

art. L2415 ø 47 (cm. 47 x 98 h.) lt. 26

art. L2506 ø 57 (cm. 57 x 126 h.) lt. 54

## kit riserva d'acqua

water reserve kit • wasserreservoir kit  
kit reserva de agua • kit réserve d'eau

art. A4256 ø 20 kit riserva d'acqua lt. 1,3

art. A4239 ø 25 kit riserva d'acqua lt. 2,5

art. A4240 ø 32 kit riserva d'acqua lt. 4

# quadrum

---



## quadrum

vaso quadro laccato • lacquered square pot  
pflanzkübel quadratisch lackiert • maceta cuadrada lacado • pot carré laqué

art. L2419 cm. **37** (cm. 37x37x 73 h.) lt. 16

art. L2420 cm. **51** (cm. 51x51x100 h.) lt. 41

# ikon



## ikon

vaso laccato • lacquered pot  
pflanzkübel lackiert • maceta lacada • pot laqué

art. L2603 ø 40 (cm. 40 x 36 h.) lt. 23

art. L2604 ø 50 (cm. 50 x 44 h.) lt. 47

art. L2605 ø 60 (cm. 60 x 53 h.) lt. 82

art. L2896 ø 70 (cm. 70 x 62 h.) lt. 130

art. L2541 ø 80 (cm. 80 x 71 h.) lt. 202

art. L2542 ø 100 (cm. 100 x 89 h.) lt. 398

art. L2543 ø 120 (cm. 120 x 107 h.) lt. 680

art. L2786 ø 140 (cm. 140 x 125 h.) lt. 1066

art. L2787 ø 160 (cm. 160 x 143 h.) lt. 1594





# khilia lights

---

Funzionali di giorno e scenografiche di notte, le lampade di questa collezione grazie alla possibilità di essere dotate di kit illuminanti garantiti e certificati sia per l'indoor che per l'outdoor, sanno arredare con la forza e la bellezza della luce ogni ambiente creando atmosfere suggestive ed esclusive.

Functional by day and scenographic by night, the lamps in this collection can be fitted with lighting kits that are guaranteed and certified for indoor and outdoor use. The finishing power and beauty of the light creates an exclusive and evocative atmosphere in any setting.

Funktionell am Tag und szeneträchtig während der Nacht sind die beleuchteten Elemente dieser Kollektion. Dank der Möglichkeit, aussen und innen eingesetzt zu werden durch entsprechende Beleuchtungs-Kits werden sie so zu Einrichtungsgegenständen, die durch die Kraft und die Schönheit des Lichtes jedem Ambiente eine suggestive und exklusive Atmosphäre verleihen.

Funcional de dia y escenográfica de noche, la lampara de ésta colección gracias a la posibilidad de estar dotada de kit luminoso garantiza y certifica su utliidad tanto para interior como exterior, diseñada con la fuerza y la belleza de la luz en cada ambiente, creando una atmósfera sugestiva y exclusiva.

Fonctionnelles de jour et scénographiques de nuit, les lampes de cette collection, grâce à la possibilité d'être dotées de kit lumineux garantis et certifiés aussi bien pour l'intérieur que pour l'extérieur, savent meubler toutes les pièces en créant des atmosphères suggestives et exclusives.

Tutte le lampade presenti in questo catalogo dispongono di un kit luce già installato.

All the lamps included in this catalogue are supplied with a light kit already installed.

Alle Leuchten dieses Kataloges werden inklusive eines montierten Beleuchtungs-Kits geliefert.

Todas las lámparas descritas en este catálogo disponen de un kit de luces ya instalado.

Tous les luminaireux présents dans ce catalogue sont équipés d'un kit d'éclairage déjà installé.

# index

---

<b>ikon</b> light	p. 100
<b>ikon</b> lighting colors	p. 108
<b>ilie</b> light	p. 95
<b>ilie</b> gloss lighting colors	p. 110
<b>kiam</b> light	p. 94
<b>kiam</b> gloss lighting colors	p. 112
<b>kube</b> sgabello light	p. 90
<b>kube</b> panca light	p. 93
<b>kube high</b> cassetta light	p. 101
<b>kube high</b> vaso light	p. 92
<b>kube high slim</b> cassetta light	p. 103
<b>kube high slim</b> vaso light	p. 102
<b>kube high slim</b> modulo light	p. 104
<b>kube tower</b> cassetta light	p. 107
<b>kube tower</b> vaso light	p. 106
<b>quadrum</b> light	p. 91
<b>sfera</b> light	p. 96
<b>sfera</b> con piedistallo light	p. 98

# kube sgabello light



## kube sgabello light (indoor)

art. 2705 cm. **40** (cm. 40x40x40h.)

art. 2708 cm. **50** (cm. 50x50x50h.)

## kube sgabello light (outdoor)

art. 2706 cm. **40** (cm. 40x40x40h.)

art. 2709 cm. **50** (cm. 50x50x50h.)

## kube rgb led light (indoor/outdoor)

art. 2707 cm. **40** (cm. 40x40x40h.)

art. 2710 cm. **50** (cm. 50x50x50h.)

# quadrum light

---



**quadrum** light (indoor)

**quadrum** light (outdoor)

**quadrum** rgb led light (indoor)

**quadrum** rgb led light (outdoor)

art. 2711 cm. **51** (cm. 51x51x100 h.)

art. 2712 cm. **51** (cm. 51x51x100 h.)

art. 2713 cm. **51** (cm. 51 x 51 x 100 h.)

art. 2714 cm. **51** (cm. 51x51x100 h.)

# kube high vaso light



## kube high light (indoor)

art. 2737 cm. 30 (cm. 30x30x70 h.)

art. 2741 cm. 40 (cm. 40x40x70 h.)

## kube high light (outdoor)

art. 2738 cm. 30 (cm. 30x30x70 h.)

art. 2742 cm. 40 (cm. 40x40x70 h.)

## kube high rgb led light (indoor)

art. 2739 cm. 30 (cm. 30 x 30 x 70 h.)

art. 2743 cm. 40 (cm. 40 x 40 x 70 h.)

## kube high rgb led light (outdoor)

art. 2740 cm. 30 (cm. 30x30x70 h.)

art. 2744 cm. 40 (cm. 40x40x70 h.)

# kube panca light

---



**kube** panca light (indoor)

art. 2755 cm. **100** (cm.100x40x40h.)

**kube** panca light (outdoor)

art. 2756 cm. **100** (cm.100x40x40h.)

**kube** rgb led light (indoor/outdoor)

art. 2757 cm. **100** (cm.100x40x40h.)

# kiam light



## kiam light (indoor)

art. 2693 cm. **35** (cm. 35 x 35 x 75 h.)

art. 2697 cm. **40** (cm. 40 x 40 x 90 h.)

## kiam light (outdoor)

art. 2694 cm. **35** (cm. 35 x 35 x 75 h.)

art. 2698 cm. **40** (cm. 40 x 40 x 90 h.)

## kiam rgb led light (indoor)

art. 2695 cm. **35** (cm. 35 x 35 x 75 h.)

art. 2699 cm. **40** (cm. 40 x 40 x 90 h.)

## kiam rgb led light (outdoor)

art. 2696 cm. **35** (cm. 35 x 35 x 75 h.)

art. 2700 cm. **40** (cm. 40 x 40 x 90 h.)



# ilie light



## ilie light (indoor)

art. 2661 ø 37 (cm. 37 x 75 h.)  
 art. 2665 ø 42 (cm. 42 x 90 h.)  
 art. 2669 ø 47 (cm. 47 x 98 h.)  
 art. 2673 ø 57 (cm. 57 x 126 h.)

## ilie light (outdoor)

art. 2662 ø 37 (cm. 37 x 75 h.)  
 art. 2666 ø 42 (cm. 42 x 90 h.)  
 art. 2670 ø 47 (cm. 47 x 98 h.)  
 art. 2674 ø 57 (cm. 57 x 126 h.)

## ilie rgb led light (indoor)

art. 2663 ø 37 (cm. 37 x 75 h.)  
 art. 2667 ø 42 (cm. 42 x 90 h.)  
 art. 2671 ø 47 (cm. 47 x 98 h.)  
 art. 2675 ø 57 (cm. 57 x 126 h.)

## ilie rgb led light (outdoor)

art. 2664 ø 37 (cm. 37 x 75 h.)  
 art. 2668 ø 42 (cm. 42 x 90 h.)  
 art. 2672 ø 47 (cm. 47 x 98 h.)  
 art. 2676 ø 57 (cm. 57 x 126 h.)

# sfera light

---



## sfera light (indoor)

art. 2639 Ø 45 (cm. 45 x 40 h.)

art. 2715 Ø 55 (cm. 55 x 50 h.)

art. 2718 Ø 65 (cm. 65 x 60 h.)

## sfera light (outdoor)

art. 2651 Ø 45 (cm. 45 x 40 h.)

art. 2716 Ø 55 (cm. 55 x 50 h.)

art. 2719 Ø 65 (cm. 65 x 60 h.)

## sfera rgb led light (indoor/outdoor)

art. 2749 Ø 45 (cm. 45 x 40 h.)

art. 2717 Ø 55 (cm. 55 x 50 h.)

art. 2720 Ø 65 (cm. 65 x 60 h.)



# sfera con piedistallo light

---



**sfera con piedistallo light (indoor)**

art. 2759 Ø 65 (cm. 65 x 70 h.)

**sfera con piedistallo light (outdoor)**

art. 2760 Ø 65 (cm. 65 x 70 h.)

**sfera rgb led light (indoor/outdoor)**

art. 2761 Ø 65 (cm. 65 x 70 h.)



# ikon light



## ikon light (indoor)

art. 2721	Ø 40	(cm. 40 x 36 h.)
art. 2725	Ø 50	(cm. 50 x 44 h.)
art. 2729	Ø 60	(cm. 60 x 53 h.)
art. 2899	Ø 70	(cm. 70 x 62 h.)
art. 2641	Ø 80	(cm. 80 x 71 h.)
art. 2653	Ø 100	(cm. 100 x 89 h.)
art. 2657	Ø 120	(cm. 120 x 107 h.)
art. 2806	Ø 140	(cm. 140 x 125 h.)
art. 2810	Ø 160	(cm. 160 x 143 h.)

## ikon light (outdoor)

art. 2722	Ø 40	(cm. 40 x 36 h.)
art. 2726	Ø 50	(cm. 50 x 44 h.)
art. 2730	Ø 60	(cm. 60 x 53 h.)
art. 2900	Ø 70	(cm. 70 x 62 h.)
art. 2642	Ø 80	(cm. 80 x 71 h.)
art. 2654	Ø 100	(cm. 100 x 89 h.)
art. 2658	Ø 120	(cm. 120 x 107 h.)
art. 2807	Ø 140	(cm. 140 x 125 h.)
art. 2811	Ø 160	(cm. 160 x 143 h.)

## ikon rgb led light (indoor)

art. 2723	Ø 40	(cm. 40 x 36 h.)
art. 2727	Ø 50	(cm. 50 x 44 h.)
art. 2731	Ø 60	(cm. 60 x 53 h.)
art. 2901	Ø 70	(cm. 70 x 62 h.)
art. 2643	Ø 80	(cm. 80 x 71 h.)
art. 2655	Ø 100	(cm. 100 x 89 h.)
art. 2659	Ø 120	(cm. 120 x 107 h.)
art. 2808	Ø 140	(cm. 140 x 125 h.)
art. 2812	Ø 160	(cm. 160 x 143 h.)

## ikon rgb led light (outdoor)

art. 2724	Ø 40	(cm. 40 x 36 h.)
art. 2728	Ø 50	(cm. 50 x 44 h.)
art. 2732	Ø 60	(cm. 60 x 53 h.)
art. 2902	Ø 70	(cm. 70 x 62 h.)
art. 2644	Ø 80	(cm. 80 x 71 h.)
art. 2656	Ø 100	(cm. 100 x 89 h.)
art. 2660	Ø 120	(cm. 120 x 107 h.)
art. 2809	Ø 140	(cm. 140 x 125 h.)
art. 2813	Ø 160	(cm. 160 x 143 h.)

# kube high casseta light



## kube high light (indoor)

art. 2745 cm. **80** (cm. 80x30x70h.)

art. 2701 cm. **100** (cm.100x40x70h.)

## kube high light (outdoor)

art. 2746 cm. **80** (cm. 80x30x70h.)

art. 2702 cm. **100** (cm.100x40x70h.)

## kube high rgb led light (indoor)

art. 2747 cm. **80** (cm. 80x30x70h.)

art. 2703 cm. **100** (cm.100x40x70h.)

## kube high rgb led light (outdoor)

art. 2748 cm. **80** (cm. 80x30x70h.)

art. 2704 cm. **100** (cm.100x40x70h.)

# kube high slim vaso light



**kube high slim** light (indoor)

**kube high slim** light (outdoor)

**kube high slim** rgb led light (indoor)

**kube high slim** rgb led light (outdoor)

art. 2796 cm. 25 (cm. 25 x 25 x 70 h.)

art. 2797 cm. 25 (cm. 25 x 25 x 70 h.)

art. 2798 cm. 25 (cm. 25 x 25 x 70 h.)

art. 2799 cm. 25 (cm. 25 x 25 x 70 h.)



# kube high slim casseta light



**kube high slim** light (indoor)

**kube high slim** light (outdoor)

**kube high slim** rgb led light (indoor)

**kube high slim** rgb led light (outdoor)

art. 2792 cm. **80** (cm. 80 x 25 x 70 h.)

art. 2793 cm. **80** (cm. 80 x 25 x 70 h.)

art. 2794 cm. **80** (cm. 80 x 25 x 70 h.)

art. 2795 cm. **80** (cm. 80 x 25 x 70 h.)

# kube high slim modulo



## kube high slim light (indoor)

art. 2800 cm. **25** (cm. 25 x 25 x 70 h.)

art. 2803 cm. **80** (cm. 80 x 25 x 70 h.)

## kube high slim light (outdoor)

art. 2801 cm. **25** (cm. 25 x 25 x 70 h.)

art. 2804 cm. **80** (cm. 80 x 25 x 70 h.)

## kube high slim rgb led light (indoor/outdoor)

art. 2802 cm. **25** (cm. 25 x 25 x 70 h.)

art. 2805 cm. **80** (cm. 80 x 25 x 70 h.)



# kube tower vaso light



**kube tower** light (indoor)

art. 2831 cm. **30** (cm. 30 x 30 x 90 h.)

**kube tower** light (outdoor)

art. 2832 cm. **30** (cm. 30 x 30 x 90 h.)

**kube tower** rgb led light (indoor)

art. 2833 cm. **30** (cm. 30 x 30 x 90 h.)

**kube tower** rgb led light (outdoor)

art. 2834 cm. **30** (cm. 30 x 30 x 90 h.)

# kube tower casseta light



**kube tower** light (indoor)

art.2835 cm. **70** (cm. 70x30x90 h.)

**kube tower** light (outdoor)

art.2836 cm. **70** (cm. 70x30x90 h.)

**kube tower** rgb led light (indoor)

art.2837 cm. **70** (cm. 70 x 30 x 90 h.)

**kube tower** rgb led light (outdoor)

art.2838 cm. **70** (cm. 70x30x90 h.)

# ikon lighting colors



non illuminato • not enlightened

## ikon light (indoor)

art. 2721	Ø 40	(cm. 40 x 36 h.)
art. 2725	Ø 50	(cm. 50 x 44 h.)
art. 2729	Ø 60	(cm. 60 x 53 h.)
art. 2899	Ø 70	(cm. 70 x 62 h.)
art. 2641	Ø 80	(cm. 80 x 71 h.)
art. 2653	Ø 100	(cm. 100 x 89 h.)
art. 2657	Ø 120	(cm. 120 x 107 h.)

## ikon light (outdoor)

art. 2722	Ø 40	(cm. 40 x 36 h.)
art. 2726	Ø 50	(cm. 50 x 44 h.)
art. 2730	Ø 60	(cm. 60 x 53 h.)
art. 2900	Ø 70	(cm. 70 x 62 h.)
art. 2642	Ø 80	(cm. 80 x 71 h.)
art. 2654	Ø 100	(cm. 100 x 89 h.)
art. 2658	Ø 120	(cm. 120 x 107 h.)



illuminato • enlightened

Utilizzando un particolare materiale tinto in massa che lascia filtrare i raggi luminosi dall'interno, è possibile ottenere un oggetto che diffonde luce colorata utilizzando un semplice kit luce standard. Di giorno la lampada si presenta come una scultura colorata, mentre di notte si accende creando suggestive atmosfere.

Using a particular dyed material, it filters the light rays from the inside, you can get an object that diffuses colored light using a simple light standards kit. By day the lamp seems a colored sculpture, while at night it glows creating evocative moods.

# ilie gloss lighting colors

---



non illuminato • not enlightened

---

## ilie light (indoor)

art. 2677 ø 37 (cm. 37 x 75 h.)

art. 2681 ø 47 (cm. 47 x 98 h.)

art. 2685 ø 57 (cm. 57 x 126 h.)

---

---

## ilie light (outdoor)

art. 2678 ø 37 (cm. 37 x 75 h.)

art. 2682 ø 47 (cm. 47 x 98 h.)

art. 2686 ø 57 (cm. 57 x 126 h.)

---





illuminato • enlightened

Utilizzando un particolare materiale tinto in massa che lascia filtrare i raggi luminosi dall'interno, è possibile ottenere un oggetto che diffonde luce colorata utilizzando un semplice kit luce standard. Di giorno la lampada si presenta come una scultura colorata, mentre di notte si accende creando suggestive atmosfere.

Using a particular dyed material, it filters the light rays from the inside, you can get an object that diffuses colored light using a simple light standards kit. By day the lamp seems a colored sculpture, while at night it glows creating evocative moods.

# kiam gloss lighting colors

---



non illuminato • not enlightened

---

**kiam** light (indoor)

art. 2689 cm. **40** (cm. 40x40x90h.)

---

**kiam** light (outdoor)

art. 2690 cm. **40** (cm. 40x40x90h.)



illuminato • enlightened

Utilizzando un particolare materiale tinto in massa che lascia filtrare i raggi luminosi dall'interno, è possibile ottenere un oggetto che diffonde luce colorata utilizzando un semplice kit luce standard. Di giorno la lampada si presenta come una scultura colorata, mentre di notte si accende creando suggestive atmosfere.

Using a particular dyed material, it filters the light rays from the inside, you can get an object that diffuses colored light using a simple light standards kit. By day the lamp seems a colored sculpture, while at night it glows creating evocative moods.

# kit led rgb light

---

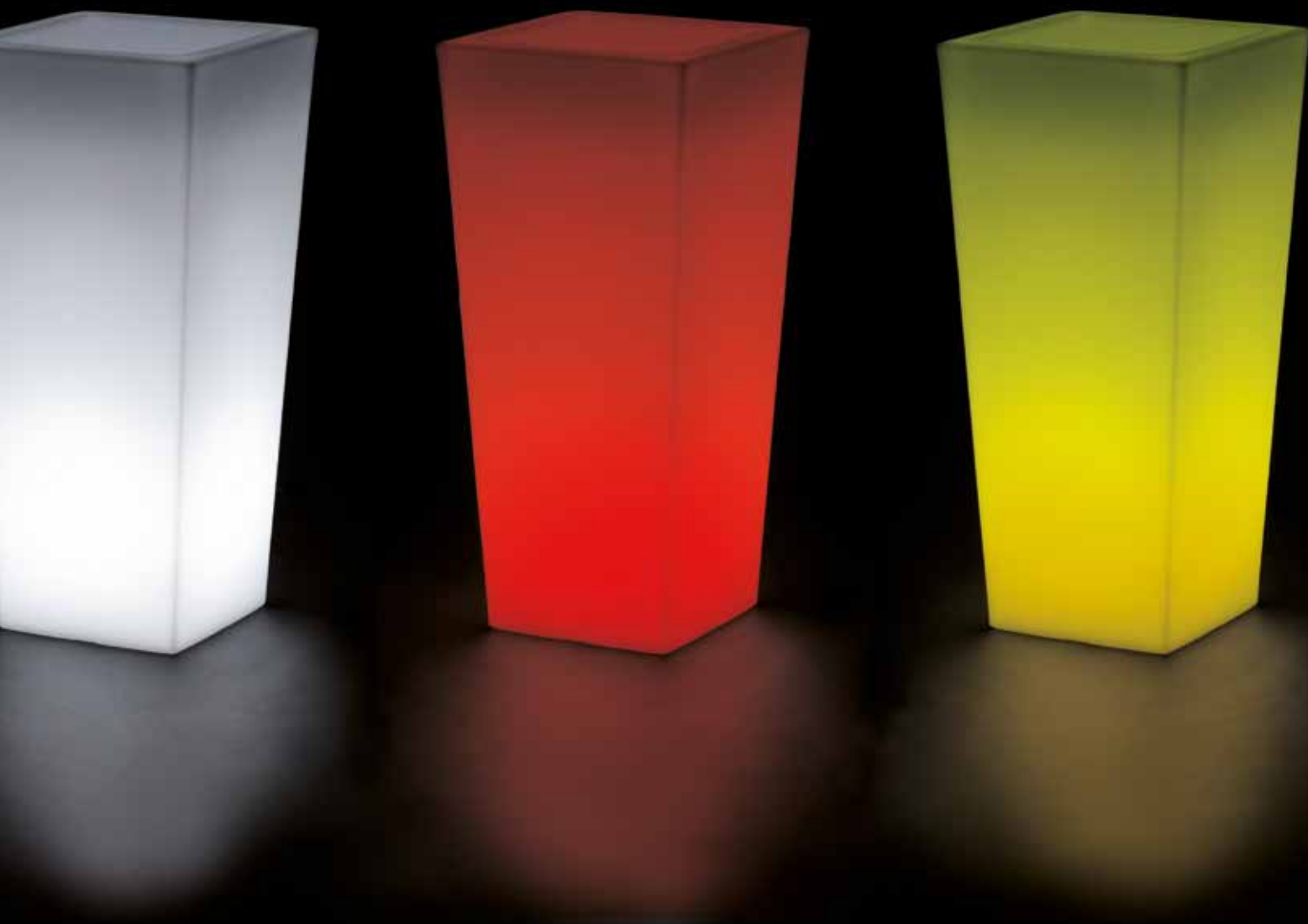

Il kit professionale applicabile a tutti i prodotti "Lights" di Khilia collection utilizza la tecnologia a risparmio energetico LED RGB, attraverso la quale è possibile trasformare ogni oggetto in una scultura luminosa e colorata. A seconda dello scenario, del contesto, o della particolare suggestione che si vuole creare, si può scegliere il colore della luce più adatto, o semplicemente lasciare che la lampada trasformi il colore lentamente in sequenza, regalando un coinvolgente spettacolo cromatico.

The professional kit, applicable to all Khilia collection "Lights", uses RGB LED technology to save energy, through which you can turn any object into a glowing colorful sculpture. Depending on the scenario, context, or that particular suggestion to be created, you can choose the most suitable light color, or simply let the lamp turn the color slowly in sequence, giving a fascinating show of color.

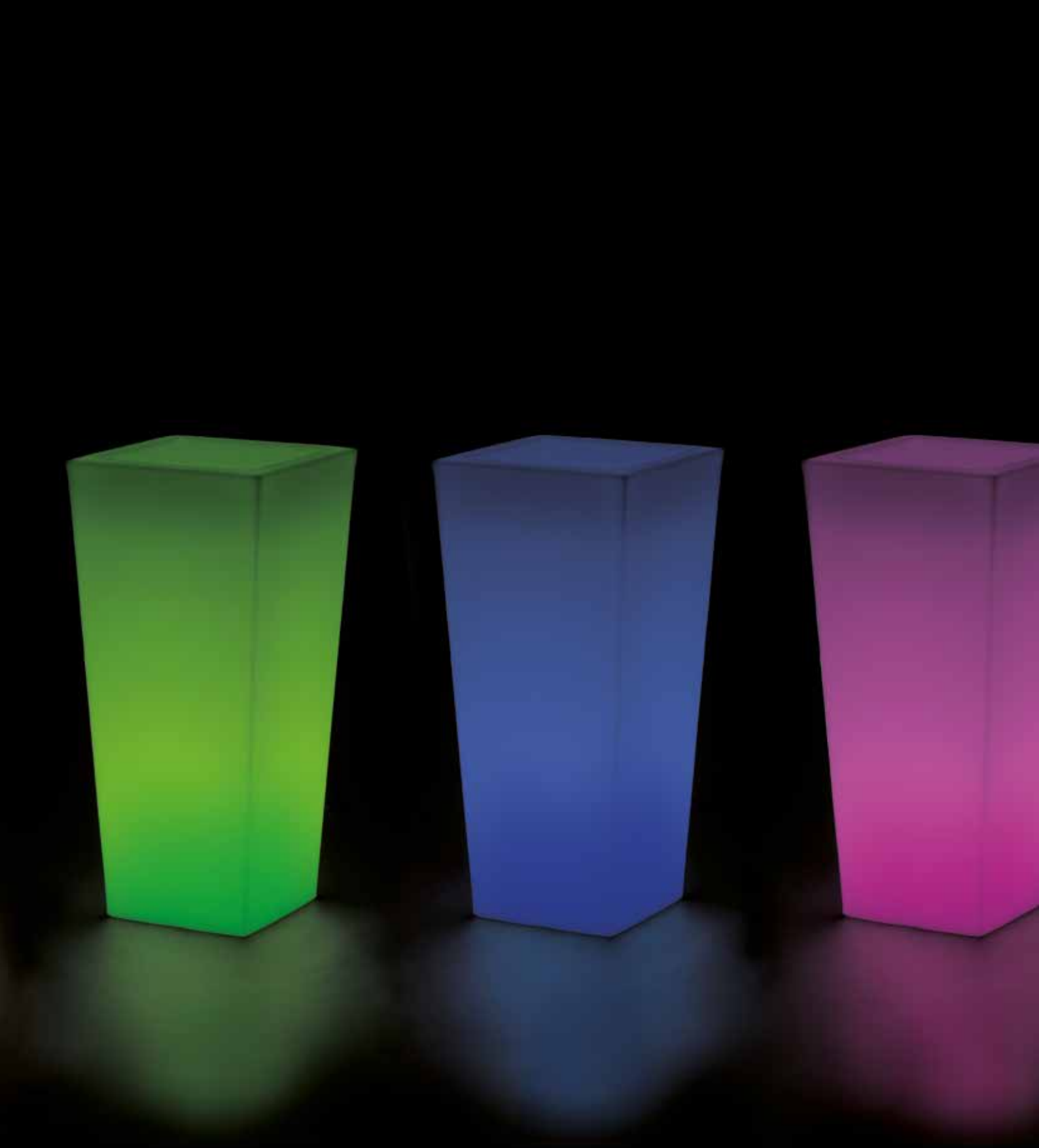

# khilia mini lights

---

Piccoli oggetti illuminati da un kit a LED bianchi da utilizzare in svariati contesti, per arredare ricreando piccoli punti di luce d'atmosfera.

Small bright objects by a white LED kit to use in a variety of contexts, to furnish and create small points of light, conferring atmosphere.

Mit weißem LED-Kit beleuchtete kleine Objekte, vielseitig einsetzbar, um zu dekorieren, kleine "Licht-Punkte" zu setzen und Atmosphäre zu schaffen.

Pequeños objetos iluminados por un kit de LED blanco para ser utilizado en diversos contextos para decorar, recreando pequeños puntos de luz en la atmósfera.

Petits objets lumineux avec un Kit LED blanc pouvant être utilisés dans différentes lieux permettant la création de petites ambiances conviviales.

# index

---

<b>mini ikon</b> light	p. 118
<b>mini kube</b> light	p. 120
<b>mini kube</b> cassetta light	p. 122
<b>mini kube</b> vaso light	p. 119
<b>mini sfera</b> light	p. 121

# mini ikon light

---



mini ikon light (indoor)

---

art. 2782 Ø 20 (cm. 20 x 17,5 h.)



# mini kube vaso light



mini kube vaso light (indoor)

art. 2783 cm. 20 (cm.20x20x20h.)

# mini kube light

---



mini kube light (indoor)

---

art. 2784 cm. 20 (cm.20 x20 x20 h.)

# mini sfera light



mini sfera light (indoor)

art. 2636 Ø 20 (cm. 20 x 18 h.)



mini kube cassetta light

mini kube cassetta light (indoor)

art. 2791 cm. 60 (cm. 60 x 20 x 20 h.)

# khilia kit luce

---

<b>khilia kit luce</b> per interni	p. 124
<b>khilia kit luce</b> per esterni	p. 125
<b>kit led rgb</b> per interni/esterni	p. 126
<b>kit led rgb a batteria con spina</b> per interni/esterni	p. 128
<b>kit mini led light</b> per interni	p. 130

# khilia kit luce per interni



art. A4279

khilia kit luce in PC per **interni**

**indoor** PC khilia light kit

khilia beleuchtungs-kit aus PC für den **indoor-einsatz**

kit luz khilia en policarbonato para **interiores**

kit lumineux khilia pour l'**intérieur** en PC

**dettagli • details • details • detalles • détails**

**piastra in policarbonato** • polycarbonate plate • platte aus polycarbonat • placa de policarbonato • plaque en polycarbonate

**cavo trasparente** • transparent cable • transparentes kabel • cable transparente • câble transparent

**pulsantiera a pedale** • foot swich • fuschalter • interruptor de pie • interrupteur à pied

**spina europea bipolare** • european bipolar plug • bipolarer eurostecker • clavija europea bipolar • prise europenne bipolaire

**lunghezza cavo** • wire length • kabellnge • longitud cable • longueur du cble: **cm. 370**

luce • light • licht • luz • ampoule

1 x 20 W



# khilia kit luce per esterni



art. A4280

khilia kit luce in PC **per esterni**

**outdoor** PC khilia light kit

khilia beleuchtung-kit aus PC für den **outdoor-einsatz**

kit luz khilia en policarbonato para **exteriores**

kit lumineux khilia pour **extérieur** en PC

**dettagli - details - details - detalles - détails**

**piastra in policarbonato** • polycarbonate plate • platte aus polycarbonat • placa de policarbonato • plaque en polycarbonate

**guscio in policarbonato** • polycarbonate shell • hülse aus polycarbonat • carcasa de policarbonato • cloche en polycarbonate

**guarnizione a tenuta** • gasket seal • dichtung • junta con empaquetadura • joint d'étanchéité

**cavo nero - black cable** • schwarzes kabel • cable negro • câble noir

**spina schuko antispruzzo** • anti-splash schuko plug • spritzgeschützter schukostecker • clavija schuko antisalpicadura

prise schuko anti-éclaboussure

**lunghezza cavo** • wire length • kabellänge • longitud cable • longueur du câble: cm. **290**

**luce • light • licht • luz • ampoule**

1 x 20 W



Tutti i vasi light outdoor di Khilia collection sono dotati di fori di drenaggio, all'interno e sul fondo del vaso, per favorire la fuoriuscita dell'acqua in eccesso.

All the outdoor light pots of the Khilia collection have drainage holes inside and on the base of the pot to allow excess water to drain away.

Alle beleuchteten Kübel für den outdoor-Einsatz der Khilia collection sind mit Abflusslöchern im Innern und am Boden des Topfes versehen, um ein Abfließen von überschüssigem Wasser zu ermöglichen.

La parte interna y el fondo de todas las macetas light outdoor de la colección Khilia disponen de agujeros de drenaje para favorecer la salida del agua en exceso.

Tous les pots lumineux outdoor de Khilia collection sont équipés d'orifices de drainage, à l'intérieur et sur le fond, pour favoriser l'écoulement de l'eau en excès.

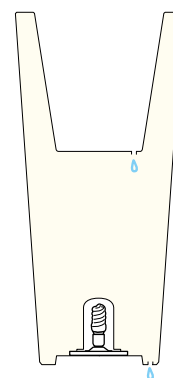

# kit led rgb per interni/esterni



art. A4307

kit led rgb per **interni/esterni**  
rgb led light kit **indoor/outdoor**

**dettagli - details - details - detalles - détails**

**telecomando** • remote control • fernbedienung • control remoto • télécommande

**cavo nero** • black cable • schwarzes kabel • cable negro • câble noir

**spina europea bipolare** • european bipolar plug • bipolarer eurostecker • clavija europea bipolar • prise européenne bipolaire

**trasformatore in 12V a parete** • 12V wall transformer • wandtransformator 12V • transformador de 12V de pared  
transformateur mural 12V

**predisposizione per base di stabilizzazione** • arrangement for stability base • vorrichtung für die stabilisierungsbasis  
predisposición para base estabilizadora • prévu pour base stabilisante

**lunghezza cavo** • wire length • kabellänge • longitud cable • longueur du câble: **cm. 500**

**luce • light • licht • luz • ampoule**

**modulo 60 led rgb 15W**

15W 60 led rgb module

60 led rgb modul 15W

módulo 60 de luces led rgb de 15 W

15W 60 led rgb module



IP 67



**Tutti i vasi light outdoor di Khilia collection sono dotati di fori di drenaggio, all'interno e sul fondo del vaso, per favorire la fuoriuscita dell'acqua in eccesso.**

All the outdoor light pots of the Khilia collection have drainage holes inside and on the base of the pot to allow excess water to drain away.

Alle beleuchteten Kübel für den outdoor-Einsatz der Khilia collection sind mit Abflusslöchern im Innern und am Boden des Topfes versehen, um ein Abfließen von überschüssigem Wasser zu ermöglichen.

La parte interna y el fondo de todas las macetas light outdoor de la colección Khilia disponen de agujeros de drenaje para favorecer la salida del agua en exceso.

Tous les pots lumineux outdoor de Khilia collection sont équipés d'orifices de drainage, à l'intérieur et sur le fond, pour favoriser l'écoulement de l'eau en excès.

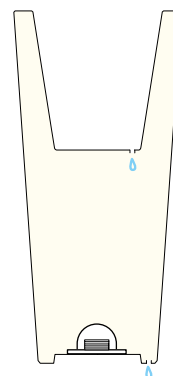



# funzionamento del telecomando a distanza

## remote control operation

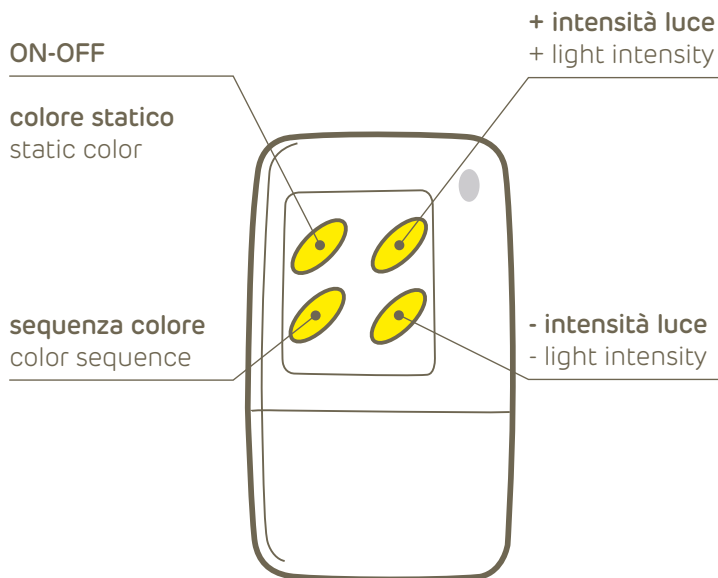

**colore statico:**  
premendo il tasto, rgb led light cambia colore potendo scegliere tra le colorazioni bianco, verde, rosso, azzurro, giallo, fucsia.

press the button to change the colour; available colours are white, green, red blue, yellow, fuchsia.

**sequenza colore:**  
premendo il tasto, rgb led light emette una luce che cambia colore in sfumatura, con andamento automatico ripetendo la sequenza predefinita verde, azzurro, fucsia, rosso, giallo.

press the colour sequence button and the rgb led light kit emits a light that fades through a colour sequence, automatically repeating the default order green, blue, fuchsia, red, yellow.

**+ intensità luce:**  
premendo il tasto + in modalità "colore statico" aumenterà l'intensità della luce.  
premendo il tasto + in modalità "sequenza colore" si aumenterà la velocità del cambio colore.

press the + button to increase the light intensity during the static colour.  
press the + button to increase the sequence speed during the colour sequence.

**- intensità luce:**  
premendo il tasto - in modalità "colore statico" diminuirà l'intensità della luce.  
premendo il tasto - in modalità sequenza colore si diminuirà la velocità del cambio colore.

press the • button to reduce the light intensity during the static colour.  
press the • button to reduce the sequence speed during the colour sequence.

Ogni rgb led light kit può essere associato a 10 telecomandi, ed ogni telecomando può essere associato a un numero infinito di rgb led light kit.

Each rgb led light kit can be associated to 10 remote controls, and every remote control can be associated to an infinite number of rgb led light kits.

# kit led rgb a batteria con spina



art. A4364

kit led rgb a batteria con spina per **interni/esterni**  
rgb led light kit with battery with plug **indoor/outdoor**

**dettagli • details • details • detalles • détails**

**kit led rgb powered by smart&green**

**autonomia 6 ore circa alla massima intensità** • autonomy 6 hours on average at maximum power • laufzeit: durchschnittlich 6 stunden bei maximaler leistung • 6 horas de autonomía a la máxima intensidad • autonomie 6 heures environ en puissance maximale

**telecomando** • remote control • fernbedienung • control remoto • télécommande

**base di ricarica con spina europea bipolare** • european bipolar plug charger • bipolarer eurostecker aufladegerät • clavija europea bipolar cargado • prise européenne bipolaire chargeur

**diffusore in polietilene resistente ai raggi u.v. e agli urti** • polyethylene plastic diffuser, resistant to u.v. and shocks  
diffusor aus polyethylenplastik, uv • beständig und stoßfest • difusor de plástico polietileno, resistente a los rayos u.v. y a los golpes  
diffuseur en plastique polyéthylène, résistant aux u.v. et aux chocs

**batteria litio polimeri 1750 mAh** • battery li-polymer 1750 mAh • akku li-polymer 1750 mAh • baterí li-polímero 1750 mAh  
batterie li-polymère 1750 mAh

**luce • light • licht • luz • ampoule**

**52 led bianchi e colorati ad alta intensità che producono 160.000 colori**

52 high intensity white and color led offering 160.000 colors

52 weiße und farbige leds mit hoher leuchtstärke, die 160.000 farben liefern

52 led blancas y de colores de alta intensidad, reproduciendo 160.000 colores

52 led blanches et couleurs hautes intensités fournissant 160.000 couleurs



IP 68



**Tutti i vasi light Outdoor di Khilia collection sono dotati di fori di drenaggio, all'interno e sul fondo del vaso, per favorire la fuoriuscita dell'acqua in eccesso.**

All the outdoor light pots of the Khilia collection have drainage holes inside and on the base of the pot to allow excess water to drain away.

Alle beleuchteten Kübel für den outdoor-Einsatz der Khilia collection sind mit Abflusslöchern im Innern und am Boden des Topfes versehen, um ein Abfließen von überschüssigem Wasser zu ermöglichen.

La parte interna y el fondo de todas las macetas light outdoor de la colección Khilia disponen de agujeros de drenaje para favorecer la salida del agua en exceso.

Tous les pots lumineux outdoor de Khilia collection sont équipés d'orifices de drainage, à l'intérieur et sur le fond, pour favoriser l'écoulement de l'eau en excès.

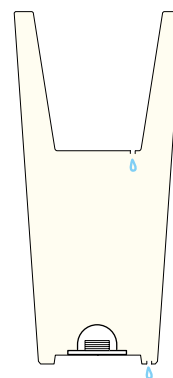

## funzionamento dei comandi nel kit rgb led light kit operation

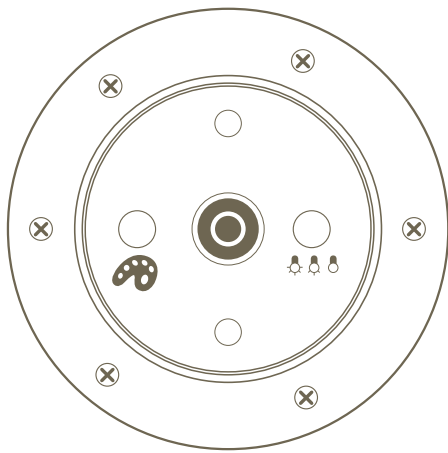

	x1	x2	x3	x4	x5
<b>Modalità/ Intensità</b>	ON Bianco	Media	Debole	Effetto Candela	OFF
<b>Mode/ Intensity</b>	ON White	Average	Low	Candle Effect	OFF
<b>Betriebsart/ Leuchtstärke</b>	ON Weiß	Mittel	Schwach	Kerzenef- fekt	OFF
<b>Modo/ Intensidad</b>	ON Blanco	Media	Débil	Efecto vela	OFF
<b>Mode/ Intensité</b>	ON Blanc	Moyenne	Faible	Effet Bougie	OFF

	x1	x2	x3
<b>Modalità</b>	Scorrimento dei colori	Blocco del colore in corso	Ripresa dello scorrimento
<b>Mode</b>	Scroll the colors	Stop on the current color	Resume scrolling
<b>Betriebsart</b>	Ablaufen der Farben	Stoppen auf der aktuellen Farbe	Wiederaufnahme des Ablaufens
<b>Modo</b>	Desfile de los colores	Parada en el color en curso	Reanudación del desfile
<b>Mode</b>	Défilement des couleurs	Arrêt sur la couleur en cours	Reprise du défilement

## funzionamento del telecomando a distanza remote control operation

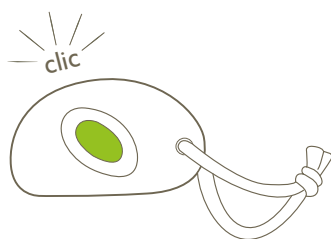

	x1	x2	x3	x4	x5	x6
<b>IT</b>	ON Bianco	Rosso	Verde	Blu	Colori rotolano	OFF
<b>EN</b>	ON White	Red	Green	Blue	Color rolling	OFF
<b>DE</b>	ON Weiß	Rot	Grün	Blau	Farben rollieren	OFF
<b>ES</b>	ON Blanco	Rojo	Verde	Azul	Colores de rodadura	OFF
<b>FR</b>	ON Blanc	Rouge	Vert	Bleu	Défilement couleurs	OFF

# kit mini led light per interni



art. A4303

kit mini led light per **interni**  
mini led light kit **indoor**

**dettagli • details • details • detalles • détails**

**cavo trasparente** • transparent cable • transparentes kabel • cable transparente • câble transparent

**spina europea bipolare** • european bipolar plug • bipolarer eurostecker • clavija europea bipolar • prise européenne bipolaire

**trasformatore in 12V a parete** • 12V wall transformer • wandtransformator 12V • transformador de 12V de pared  
transformateur mural 12V

**pulsantiera** • swich • swich • interruptor • télécommande

**luce • light • licht • luz • ampoule**

**modulo 6 led bianchi 1,5 W**

1,5 W white 6 led module

modul mit 6 weißen led's – 1,5 Watt

módulo 6 led blanco 1,5 W

module 6 led blanches 1,5 W





# khilia accessori • accessories

---

Euro3plast mette a disposizione dei pratici accessori da aggiungere ai vasi di Khilia collection. Kit riserva d'acqua, in diverse forme e dimensioni, abbinabili a svariati articoli sia per un uso indoor che outdoor.

Euro3plast provides practical accessories to add to the Khilia collection pots.

The water reserve kit, in various shapes and sizes, can be combined with a range of indoor and outdoor items.

Euro3plast bietet praktisches Zubehör an, in Verbindung mit den Töpfen der Khilia collection. Das Wasserreservoir kit-Kit, erhältlich in verschiedenen Formen und Größen, kann mit vielen Indoor- und Outdoor-Gefäßen kombiniert werden.

Euro3plast ofrece prácticos accesorios que se añaden a la colección de macetas Khilia collection.

Kit de reserva de agua, en diferentes formas y tamaños, junto con varios artículos para su uso tanto en interior como exterior.

Euro3plast met à disposition des accessoires pratiques à ajouter aux pots de Khilia collection. Kit réserve d'eau, en différentes formes et dimensions, utiles à plusieurs articles soit pour un usage intérieur ou extérieur.

# index

---

kit riserva d'acqua

p. 134

# kit riserva d'acqua

---





La collezione Khilia vi propone una soluzione semplice ed intuitiva mettendo a vostra disposizione un pratico kit per dotare i vasi di un'utile riserva d'acqua. Grazie ad una griglia ed all'argilla che rilascia lentamente l'umidità all'interno del vaso, le piante possono ricevere l'acqua necessaria dall'ampio bacino sottostante, diventando autosufficienti per svariati giorni. L'unica cosa di cui vi dovrete preoccupare sarà quella di controllare di tanto in tanto il livello dell'acqua nell'indicatore.

The Khilia collection offers a simple and intuitive method by providing an easy-to-use kit for fitting pots with a very practical water reserve. The grid and clay slowly release moisture into the pot so the plants receive an adequate amount of water from the large container underneath, which makes the pot self-sufficient for several days. The only thing you have to remember is to check the water level indicator every once in a while.

Die Khilia kollektion bietet hierfür eine einfache Lösung für Sie in Form eines praktischen Kits für eine Wasserbevorrattung. Dank eines Einsatzes und eines speziellen Wasserstandsanzeigers/Einfüllstutzens, der nach und nach die Feuchtigkeit in das Gefäß abgibt, können sich die Pflanzen über mehrere Tage aus dem Reservoir bedienen. Sie müssen lediglich von Zeit zu Zeit den Wasserstandanzeiger kontrollieren.

La colección Khilia le propone una solución simple e intuitiva poniendo a su disposición un práctico kit para dotar a la maceta de una útil reserva de agua. Gracias a una rejilla y una arcilla que proporciona lentamente la humedad en el interior de la maceta, la planta puede recibir el agua necesaria del depósito, abasteciéndose durante varios días. La única cosa que debe preocuparle será la de controlar de vez en cuando el nivel del agua en el indicador.

La collection Khilia vous propose une solution simple et intuitive en mettant à votre disposition un kit pratique pour équiper les pots d'une réserve d'eau utile. Grâce à une grille et à une argile qui diffuse lentement l'humidité à l'intérieur du pot, les plantes peuvent recevoir l'eau nécessaire du réservoir sous-jacent, devenant autonomes pour plusieurs jours. L'unique chose dont vous devrez vous préoccuper sera de vérifier de temps en temps le niveau d'eau sur l'indicateur.



**griglia divisoria**  
separator  
trennboden  
separador  
plateau de séparation

**indicatore del livello dell'acqua**  
water level indicator  
wasserstandsanzeiger  
indicador del nivel de agua  
indicateur de niveau d'eau

**argilla espansa**  
expanded clay  
blähton  
arcilla expandida  
argile expansée

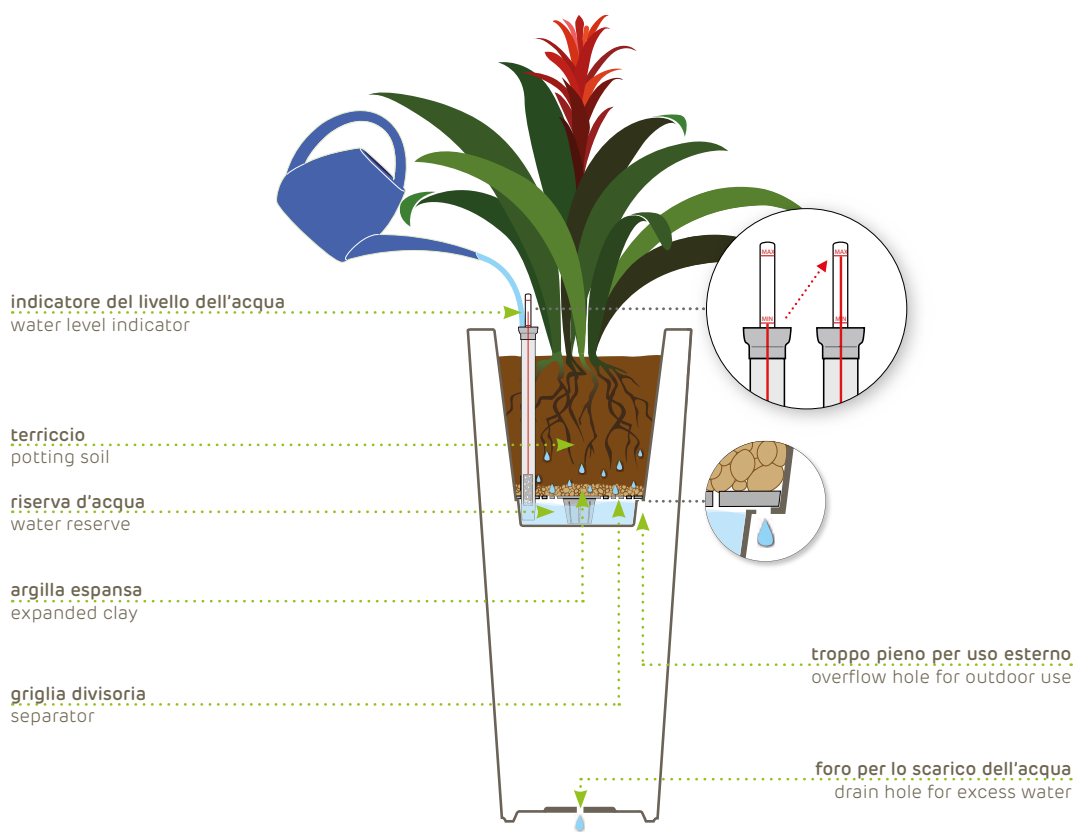

**indicatore del livello dell'acqua**  
water level indicator

**terriccio**  
potting soil

**riserva d'acqua**  
water reserve

**argilla espansa**  
expanded clay

**griglia divisoria**  
separator

**troppo pieno per uso esterno**  
overflow hole for outdoor use

**foro per lo scarico dell'acqua**  
drain hole for excess water

# khilia

utilizzo: coprivaso

## indoor

utilizzo come **coprivaso**  
used as **cachepot**  
nutzung als **übertopf**  
uso como **macetero**  
utilisé comme **cache-pot**

Il vaso Khilia può essere utilizzato come coprivaso. Inserire direttamente la pianta col suo contenitore d'origine all'interno del vaso Khilia: in questo modo il vaso funge da sottovaso e da riserva d'acqua.

The Khilia pot can be used as a cachepot. Place the plant with its original container inside the Khilia pot. It replaces the saucer and acts as a water reserve.

Die Kübel der Khilia Kollektion können als Übertopf verwendet werden. Setzen Sie hierzu die Pflanze mit ihrem ursprünglichen Pflanztopf direkt in den Kübel der Khilia Collection: Auf diese Weise dient der Topf als Untersetzer und Wasserreservoir.

La maceta Khilia puede utilizarse como macetero. Colocar directamente la planta con su recipiente original dentro de la maceta Khilia: de esta forma, la maceta cumple la función de plato y de reserva de agua.

Le pot Khilia peut être utilisé comme cache-pot. Introduire directement la plante dans son pot d'origine à l'intérieur du pot Khilia: le pot sert ainsi de soucoupe et de réserve d'eau.

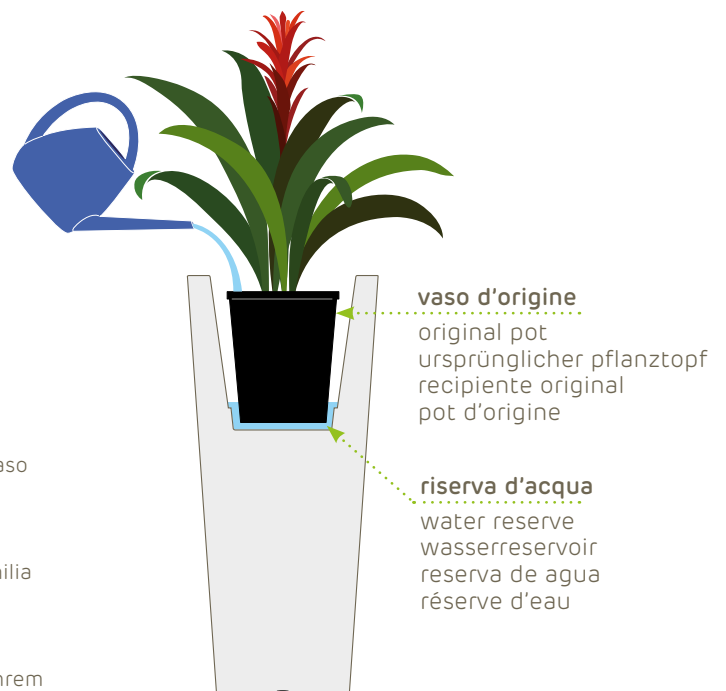

# suggestion: cachepot

## outdoor

utilizzo come **coprivaso**  
used as **cachepot**  
nutzung als **übertopf**  
uso como **macetero**  
utilisé comme **cache-pot**

Se il vaso viene posizionato all'esterno, è necessario praticare un foro all'interno del vaso nel punto indicato e togliere il tappo filettato dal fondo del vaso. In caso di pioggia i fori permetteranno all'acqua in eccesso di fuoriuscire dal vaso. Quindi inserire direttamente la pianta col suo contenitore all'interno del vaso Khilia: in questo modo il vaso funge da sottovaso e da riserva d'acqua.

When using the pot outdoors drill a hole on the inside as indicated in the image on the left and remove the threaded plug from the base of the pot. The holes will allow excess rainwater to drain away.

Place the plant with its original container inside the Khilia pot. It replaces the saucer and acts as a water reserve.

Wenn der Pflanzkübel im Freien aufgestellt wird, muss an der angegebenen Stelle ein Loch gebohrt werden und der Gewindestopfen am Boden des Topfs entfernt werden. Bei Regen kann überschüssiges Wasser durch diese Löcher abfließen. Stellen Sie die Pflanze mit ihrem ursprünglichen Pflanztopf direkt in den Khilia Pflanzkübel: Auf diese Weise dient der Topf als Untersetzer und Wasserreservoir.

Si la maceta se coloca al aire libre, es necesario hacer un agujero en la parte interna de la maceta, en el punto indicado, y quitar el tapón roscado del fondo. En caso de lluvia los agujeros facilitarán la salida del agua en exceso.

Colocar directamente la planta con su recipiente original dentro de la maceta Khilia: de esta forma, la maceta cumple la función de plato y de reserva de agua.

Si le pot est placé à l'extérieur, il est nécessaire d'en percer l'intérieur à l'endroit indiqué et d'enlever le bouchon fileté du fond du pot. En cas de pluie, les orifices permettront l'écoulement de l'eau en excès.

Puis introduire directement la plante dans son pot d'origine à l'intérieur du pot Khilia: le pot sert ainsi de soucoupe et de réserve d'eau.

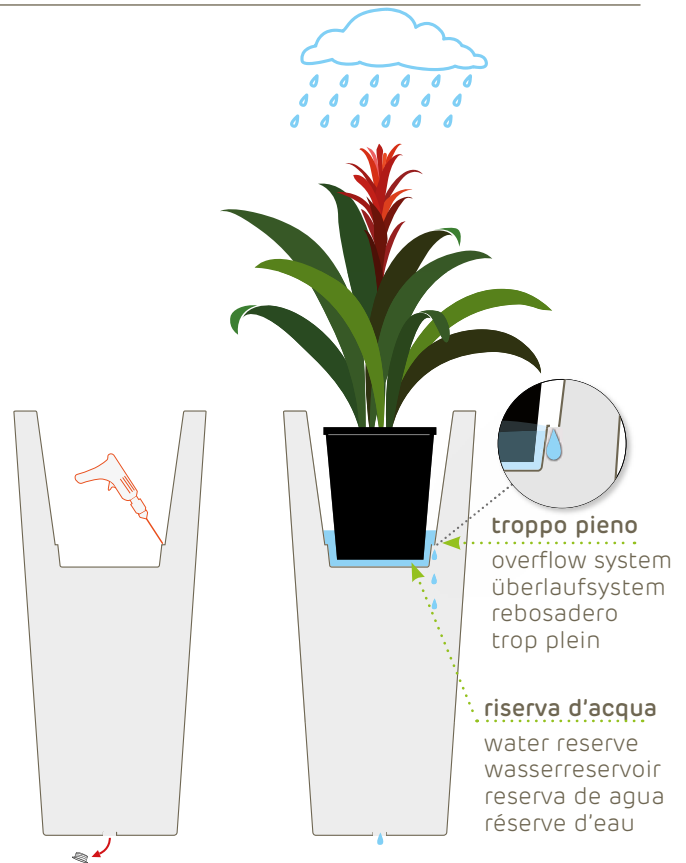

# khilia

utilizzo: vaso

## indoor

utilizzo come **vaso**

used as **pot**

nutzung als **pflanzkübel**

uso como **maceta**

utilisé comme **pot**

1. Versare uno strato di argilla espansa sul fondo del vaso.
  2. Stendere uno strato di tessuto-non-tessuto o di juta.
  3. Coprire quindi con uno strato di terriccio di 3-5 cm.
  4. Togliere la pianta dal suo contenitore d'origine e collocarla nel vaso Khilia.
1. Put some expanded clay into the bottom of the pot.
  2. Add a layer of non-woven fabric or hessian.
  3. Cover the expanded clay with 3-5 cm. of potting soil.
  4. Remove the plant from its original container and place it inside the Khilia pot.
1. Geben Sie eine Schicht Blähton auf den Boden des Pflanzkübels.
  2. Breiten Sie hierüber eine Schicht Vlies oder Jute aus.
  3. Bedecken Sie den Blähton dann mit einer Schicht Blumenerde (ca. 3-5 cm).
  4. Nehmen Sie nun die Pflanze aus ihrem ursprünglichen Pflanztopf und setzen Sie diese in den Khilia Pflanzkübel.
1. Disponer una capa de arcilla expandida en el fondo de la maceta.
  2. Extender una capa de tejido no tejido o de yuta.
  3. Cubrir con una capa de mantillo de humus de 3-5 cm.
  4. Quitar la planta de su recipiente original y colocarla en la maceta Khilia.
1. Verser un lit d'argile expansée sur le fond du pot.
  2. Étendre une épaisseur de tissu non tissé ou de toile de jute.
  3. Puis couvrir avec une couche de terreau de 3-5 cm.
  4. Enlever la plante de son pot d'origine et la planter dans le pot Khilia.

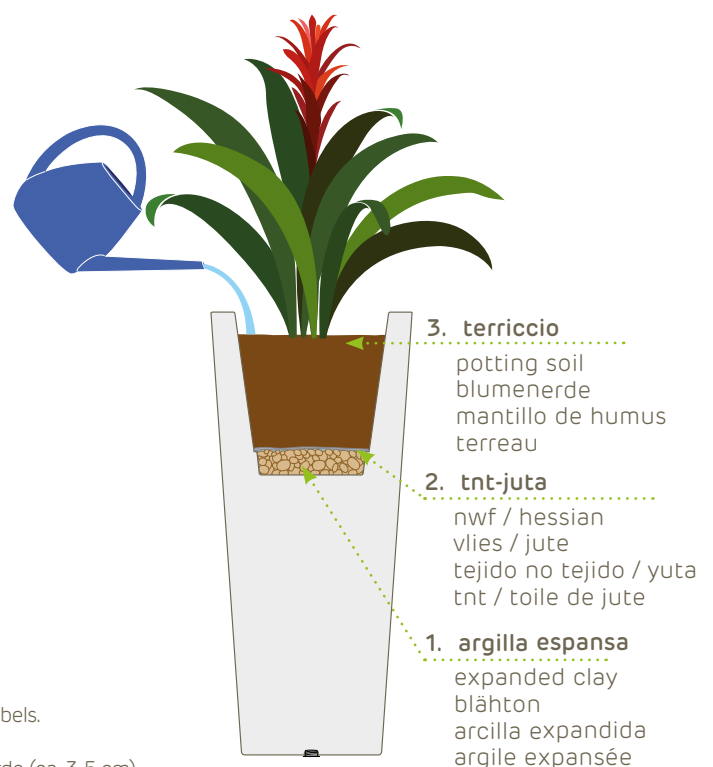

# suggestion: pot

## outdoor

utilizzo come **vaso**

used as **pot**

nutzung als **pflanzkübel**

uso como **maceta**

utilisé comme **pot**

1. Forare l'interno del vaso nel punto indicato (troppo pieno) e togliere il tappo filettato dal fondo del vaso. In caso di pioggia i fori permetteranno all'acqua in eccesso di fuoriuscire dal vaso.
2. Versare uno strato di argilla espansa sul fondo del vaso fino a coprire il foro di "troppo pieno".
3. Stendere uno strato di tessuto-non-tessuto o di juta.
4. Coprire quindi con uno strato di terriccio di 3-5 cm.
5. Collocare la pianta nel vaso.

1. When placed outdoor, it is necessary to drill the pot at the market die at the shown height to help emptying the excess of water in case of heavy rain.
2. Put some expanded clay into the bottom of the pot.
3. Add a layer of hessian.
4. Cover the expanded clay with 3-5 cm. of potting soil.
5. Set the plant down into the pot.

1. Bohren Sie an der angegebenen Stelle (Überlauf) ein Loch in den Pflanzkübel und entfernen Sie den Gewindestopfen am Boden des Topfes. Bei Regen kann überschüssiges Wasser durch diese Löcher abfließen.
2. Geben Sie eine Schicht Blähton auf den Boden des Pflanzkübels, bis das "Überlauf-Loch" bedeckt ist.
3. Breiten Sie hierüber eine Schicht Vlies oder Jute aus.
4. Bedecken Sie den Blähton dann mit einer Schicht Blumenerde (ca. 3-5 cm).
5. Nehmen Sie nun die Pflanze aus ihrem ursprünglichen Pflanztopf und setzen Sie diese in den Khilia Pflanzkübel.

1. Perforar la parte interna de la maceta, en el punto indicado (rebosadero), y quitar el tapón roscado del fondo de la maceta. En caso de lluvia los agujeros facilitarán la salida del agua en exceso.
2. Disponer una capa de arcilla expandida en el fondo de la maceta hasta cubrir el agujero del rebosadero.
3. Extender una capa de tejido no tejido o de yuta.
4. Cubrir con una capa de mantillo de humus de 3-5 cm.
5. Colocar la planta en la maceta.

1. Percer l'intérieur du pot à l'endroit indiqué (trop plein) et enlever le bouchon fileté du fond du pot. En cas de pluie, les orifices permettront l'écoulement de l'eau en excès.
2. Verser un lit d'argile expansée sur le fond du pot jusqu'à ce que l'orifice de "trop plein" soit couvert.
3. Étendre une épaisseur de tissu non tissé ou de toile de jute.
4. Puis couvrir avec une couche de terreau de 3-5 cm.
5. Planter la plante dans le pot.

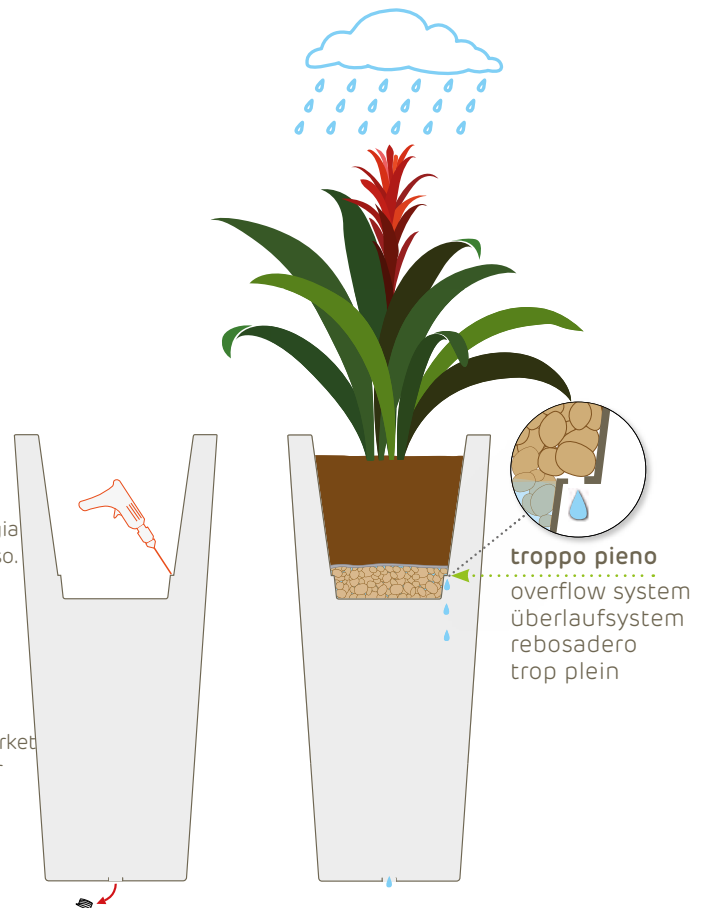

# khilia

utilizzo: coprivaso

suggestions: pot cachepot

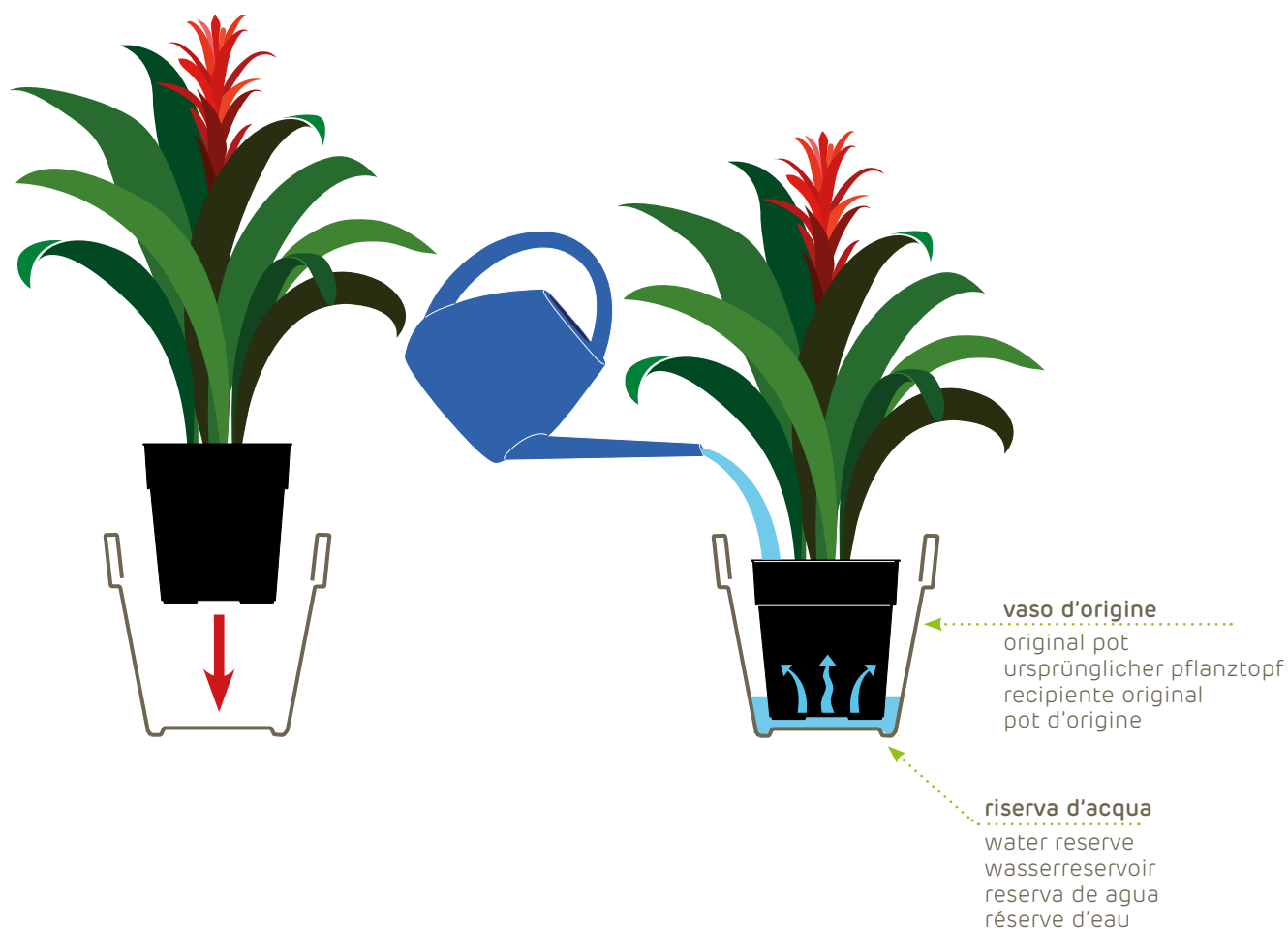

# khilia

utilizzo: vaso con sottovaso

suggestions: pot with saucer

indoor

outdoor



**riserva d'acqua**  
water reserve  
wasserreservoir  
reserva de agua  
réserve d'eau

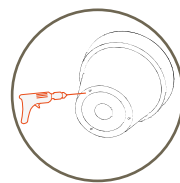

**forare**  
drill  
bohren  
perforar  
percer



**riserva d'acqua**  
water reserve  
wasserreservoir  
reserva de agua  
réserve d'eau

# khilia

stabilità • stability

## stabilità

extra stability

stabilität

estabilidad

stabilité

1. Per dare una maggiore stabilità al vaso, si consiglia di togliere il tappo filettato dal fondo del vaso e riempire l'interno con sabbia oppure ghiaio.
2. In caso di esposizione al sole, per evitare che la pressione all'interno del vaso provochi modifiche nella forma, si consiglia di praticare dei fori nella parte superiore interna del vaso, consentendo così il passaggio dell'aria.

1. To give more stability to the pot remove the threaded plug from the base and fill up with sand or gravel.
2. To prevent the pressure inside the pot from altering its shape, we recommend drilling some air vent holes around the top.

1. Um dem Pflanzkübel eine bessere Stabilität zu geben, wird empfohlen, den Gewindestopfen vom Boden des Topfs zu entfernen und das Topfinnere mit Kies zu befüllen.
2. Damit der Druck im Inneren des Gefäßes keine Änderungen der Form verursacht, wird empfohlen, Löcher in den oberen Teil der inneren Wand zu bohren, sodass die Luft zirkulieren kann.

1. Si se desea dar una mayor estabilidad a la maceta, se aconseja quitar el tapón roscado del fondo y llenar la parte interna con gravilla.
2. Para evitar que la presión dentro de la maceta provoque cambios en la forma, se recomienda perforarla en la parte superior interna de la misma, permitiendo así el paso del aire.

1. Pour donner plus de stabilité au pot, il est conseillé d'enlever le bouchon fileté du fond du pot et de remplir l'intérieur de gravier.
2. Afin d'éviter qu'une pression ne crée des déformations, nous vous conseillons de faire des trous dans la partie supérieure intérieure du pot, permettant ainsi une évacuation d'air.

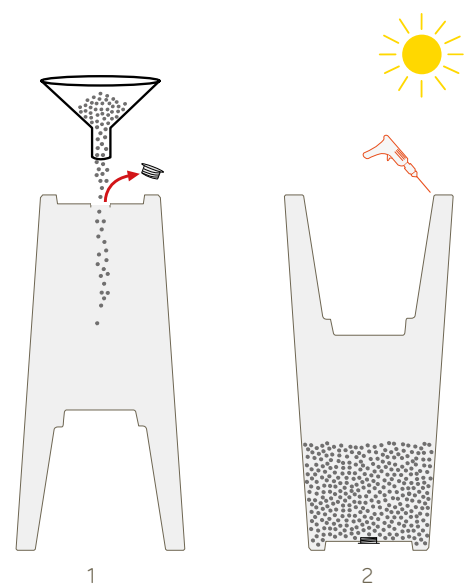



# khilia accessori • accessories

## ruote

rollers  
rollen  
ruedas  
roulettes

Alcuni articoli della linea Khilia collection sono forniti di ruote a pattino con sfera in plastica per facilitarne lo spostamento.

Some articles of the Khilia Collection line are supplied with plastic ball transfers for easy moving.

Einige Artikel der Khilia Collection sind mit Kunststoff-Gleitrollen versehen, um leichter bewegt werden zu können.

Para facilitar el desplazamiento, algunos artículos de la Colección Khilia disponen de ruedas con bola de transferencia de plástico.

Certains articles de la gamme Khilia Collection sont équipés de roulettes avec roulements à billes en plastique pour en faciliter le déplacement.



## portacassetta

bracket  
halter  
portajardinera  
accroche

Portacassetta in metallo per cassetta **mini kube** cm. 50

Holder in metal for **mini kube** plant box cm. 50

Pflanzkasten-halter aus metall für kasten **mini kube** cm. 50

Portajardinera en metal para jardinera **mini kube** cm. 50

Support accroche métal pour la balconnière **mini kube** cm. 50



# khilia awvertenze

## 1. Tutti i prodotti sono utilizzabili sia negli spazi interni che esterni.

The entire range of products can be used indoors or outdoors.

Alle Produkte können sowohl im Indoor- als auch im Outdoor-Bereich genutzt werden.

Todos los artículos pueden utilizarse en espacios internos y externos.

Tous les produits sont utilisables à la fois pour l'intérieur que pour l'extérieur.

## 2. Non posizionare l'articolo su una superficie irregolare o inclinata, per evitare movimenti incontrollati.

Do not position the product on an uneven or sloping surface; this will avoid uncontrolled movements.

Stellen Sie den Artikel nicht auf eine unebenen oder schräge Fläche, um ein Umkippen des Topfes zu vermeiden.

No colocar la maceta sobre una superficie irregular o inclinada para evitar que se produzcan movimientos incontrolables.

Ne pas poser l'article sur une surface irrégulière ou inclinée afin d'en éviter les mouvements incontrôlés.

## 3. Tenere l'articolo lontano da fonti di calore.

Keep the article away from heat sources.

Halten Sie den Artikel von Hitzequellen fern.

Colocar la maceta lejos de fuentes de calor.

Garder l'article loin des sources de chaleur.

## 4. Gli articoli con pareti dritte realizzati con la tecnica "rotazionale" possono presentare delle non planarità (warpage) che potrebbero accentuarsi qualora il prodotto venisse esposto alla luce diretta del sole.

Products with straight walls made using the rotational moulding system may show some warping that could become more obvious if the pot is exposed to direct sunlight.

Artikel mit geraden Wänden, die im Rotations-Verfahren hergestellt werden, können Unebenheiten aufweisen, die sich verstärken könnten, wenn das Produkt dem direkten Sonnenlicht ausgesetzt wird.

Las macetas con paredes rectas realizadas con la técnica de rotomoldeo pueden presentar zonas onduladas que podrían acentuarse si la maceta se expone a la luz directa del sol.

Les articles aux parois carrées et/ou rectangulaires, réalisés selon la technique "rotomoulé", peuvent présenter des irrégularités dans certains cas d'exposition directe à la lumière du soleil.

## 5. Pulire gli articoli con una spugna bagnata con acqua e detergente liquido neutro. Risciacquare con un panno bagnato. Si raccomanda di evitare l'uso di panni abrasivi e di detergenti contenenti solventi e/o alcool etilico. In caso di sporco ostinato richiedere il detergente Euro3plast.

Clean the articles with a damp cloth and neutral liquid detergent. Rinse with a clean damp cloth. Do not use abrasive cloths or cleaning agents containing solvents and/or ethyl alcohol. For stubborn stains use the special Euro3plast detergent.

Die Artikel können mit einem nassen Schwamm und neutralem flüssigen Reinigungsmittel gereinigt werden. Bei Nutzung eines Reinigungsmittels wischen Sie den Artikel nachträglich noch einmal mit einem feuchten Tuch nach. Verwenden Sie keine Tücher, Schwämme oder Reinigungsmittel, die eine schleifende, schmirgelnde Wirkung haben sowie Lösemittel und/oder Äthylalkohol enthalten. Bei hartnäckigem Schmutz können Sie bei Euro3plast ein Reinigungsmittel anfordern.

Limpiar las macetas con una esponja mojada con agua y detergente líquido neutro. Enjuagar con una bayeta mojada. Se recomienda no utilizar bayetas abrasivas o detergentes que contengan disolventes y/o alcohol etílico. En caso de suciedad fuerte utilizar el detergente Euro3plast.

Nettoyer les articles avec une éponge mouillée d'eau et de détergent liquide neutre. Rincer avec un chiffon mouillé. Il est recommandé d'éviter l'utilisation de chiffons abrasifs et de détergents contenant des solvants et/ou de l'alcool éthylique. En cas de saleté incrustée, demander le détergent Euro3plast.

# warnings

---

## LIGHTS

### 1. In caso di sostituzione della lampadina, assicurarsi che la presa di corrente sia scollegata.

Before replacing a bulb make sure that the power plug has been disconnected.  
Stellen Sie beim Auswechseln der Birne sicher, dass die Stromversorgung abgetrennt ist.  
En caso de sustitución de la bombilla, controlar que el enchufe esté desconectado.  
En cas de remplacement de l'ampoule, s'assurer que la prise est débranchée.

### 2. Nel caso in cui RGB LED LIGHT KIT viene smontato dal corpo lampada, evitare il contatto diretto dello sguardo con i LED accesi.

If removing the RGB LED LIGHT KIT from the lamp structure, avoid direct eye contact with the LEDs if lit up.  
Falls das RGB LED BELEUCHTUNGS-KIT vom Lampenkörper demontiert wird, vermeiden Sie den direkten Blickkontakt mit den eingeschalteten LEDs.  
Si el kit de luces led RGB está desmontado del cuerpo de la lámpara, evitar el contacto directo de los ojos con los led encendidos.  
Au cas où le Kit d'éclairage RGB LED serait démonté du corps de la lampe, éviter le contact direct du regard avec les LED allumés.

### 3. Collegare la spina dell'apparecchio in una presa collocata in un luogo protetto dalla pioggia e dagli spruzzi d'acqua.

Connect the plug of the appliance to a power outlet that is located in a sheltered position, protected from rain and water splashes.  
Stecken Sie den Gerätestecker in eine Steckdose, die sich an einem vor Regen und Wasserspritzern geschützten Ort befindet.  
Enchufar el aparato en un enchufe protegido contra la lluvia y las salpicaduras de agua.  
Brancher l'appareil à une prise située dans un endroit protégé de la pluie et des éclaboussures.

### 4. Se il cavo flessibile esterno di questo apparecchio viene danneggiato, deve essere sostituito esclusivamente dal costruttore, dal suo servizio di assistenza, o da personale qualificato equivalente, al fine di evitare pericoli.

If the external flexible cable of this appliance is damaged it must be replaced by either the manufacturer, the manufacturer's customer assistance service or by equivalent qualified personnel, in order to prevent possible hazards.

Wenn das biegsame äußere Kabel der Artikel beschädigt wird, darf es ausschließlich vom Kabelhersteller, von dessen Kundendienst oder von äquivalentem Fachpersonal ausgewechselt werden, um Gefahren zu vermeiden.

Para evitar peligros, si el cable flexible exterior de este aparato está dañado, lo podrá sustituir exclusivamente el fabricante, el servicio de asistencia o personal cualificado.

Si le câble souple externe de l'appareil est endommagé, le faire remplacer exclusivement par le constructeur, son service après-vente ou par du personnel qualifié équivalent, afin d'éviter tout danger.

### 5. Nelle versioni sprovviste di interruttore sul cavo di alimentazione, collegare la spina dell'apparecchio sotto una presa comandata da interruttore.

For models that are not equipped with an inline on/off switch, connect the plug of the appliance to a switch controlled outlet.  
Verbinden Sie die Artikel, welche nicht mit Schalter am Kabel ausgestattet sind mit einer mit Schalter versehenen Steckdose.  
En las versiones que no disponen de interruptor en el cable de alimentación, conectar la clavija del aparato en un enchufe accionado por interruptor.  
Dans les versions exemptes d'interrupteur sur le câble d'alimentation, brancher la fiche de l'appareil à une prise commandée par un interrupteur.

### 6. Tutti i vasi light Outdoor di Khilia collection sono dotati di fori di drenaggio, all'interno e sul fondo del vaso, per favorire la fuoriuscita dell'acqua in eccesso. Nel caso si volesse introdurre una pianta ornamentale, si consiglia di non mettere la terra direttamente all'interno del vaso, ma posizionare un sottovaso e un vaso di contenimento per evitare ostruzioni ai fori di drenaggio e mantenere pulito l'interno del vaso.

The entire Outdoor light pots range from the Khilia collection have drain holes, inside and on the base, to allow excess water to drain away.  
To avoid blocking the drainage holes and to keep the pot clean, we recommend against putting the planting medium or the plant directly in the pot; it is preferable to use the original container and place it with a saucer of suitable size in the Khilia collection pot.

Alle beleuchteten Pflanzgefäße für den Outdoor-Bereich der Khilia collection sind mit Abflusslöchern im Innern und am Boden des Topfes versehen, um ein Abfließen von überschüssigem Wasser zu ermöglichen. Um Verstopfungen an den Abflusslöchern zu vermeiden und den Pflanzkübel sauber zu halten, wird empfohlen, die Erde oder die Pflanze nicht direkt in den Topf zu geben, sondern einen separaten Topf geeigneter Abmessung, sowie einen Untersetzer in den Pflanzkübel der Khilia collection hinein zu stellen.

La parte interna y el fondo de todas las macetas Light Outdoor de la Colección Khilia disponen de agujeros de drenaje para favorecer la salida del agua en exceso. Para evitar que los agujeros de drenaje se obstruyan y para mantener la maceta limpia, se aconseja no poner tierra ni colocar la planta directamente dentro de la maceta, sino colocar un plato o el recipiente original de la planta cuyas dimensiones sean adecuadas a la maceta de la Colección Khilia.

Tous les pots lumineux Outdoor de Khilia collection sont équipés d'orifices de drainage, à l'intérieur et sur le fond, pour favoriser l'écoulement de l'eau en excès. Pour éviter que les orifices de drainage ne se bouchent et garder le pot propre, il est conseillé de ne pas mettre la terre ou la plante directement dans le pot, mais de mettre un pot et un dessous de pot aux dimensions adéquates dans le pot Khilia collection.

# khilia merchandising tools

---

Per i clienti, la visibilità dei prodotti e dei servizi è di massima importanza durante l'acquisto! Euro3plast è in grado di fornire attrezzature innovative per realizzare diverse soluzioni espositive. Il visual Merchandising è dinamico, in continuo cambiamento ed è essenziale usare le tecniche più aggiornate per incrementare le prestazioni di vendita. Sono a vostra disposizione teli da appendere, totem da terra e copripallet per creare pedane di diverse misure, atte ad esporre i prodotti euro3plast!

Product visibility and services are of crucial importance for customers when making a purchase! Euro3plast can provide innovative tools for creating various display solutions. Visual merchandising is dynamic, continually changing and the use of cutting edge techniques is vital to ensure increased sales performance. We can supply hanging banners, floor standing totems and cover pallet to create platforms of various sizes for displaying euro3plast products!

Für den Kunden ist die Optik der Produkte und die Service-Leistung während des Einkaufs von größter Wichtigkeit! Euro3plast ist in der Lage, innovative Merchandising-Instrumente anzubieten. "Visual Merchandising" ist dynamisch und in ständiger Veränderung begriffen. Es ist von grundlegender Bedeutung, die aktualisiertesten Techniken einzusetzen, um die Verkaufsleistungen zu erhöhen. Zu Ihrer Verfügung stehen Banner, Aufsteller und Palettenabdeckungen, um Stellflächen mit verschiedenen Abmessungen zu kreieren, auf denen die Produkte von euro3plast präsentiert werden können!

¡Para los clientes, es fundamental la exposición de los productos y la presentación clara de los servicios durante la compra! Euro3plast puede proporcionar herramientas innovadoras para realizar distintas soluciones expositivas. El mercado visual es dinámico y en continua evolución, y es esencial utilizar las técnicas más actualizadas para incrementar las prestaciones de venta. ¡Se dispone también de pancartas para colgar, tótem para apoyar en el suelo y cubrepalets que crean tarimas de distintas medidas, idóneas a la exposición de los productos euro3plast!

Pour les clients, la visibilité des produits et des services est d'une extrême importance lors de l'achat! Euro3plast est en mesure de fournir des équipements innovants pour réaliser différentes solutions d'exposition. Le merchandising visuel est dynamique, continuellement en évolution et il est essentiel d'utiliser des techniques à jour pour augmenter les actions de vente. Des toiles à suspendre, des totems à poser au sol et des habillage-palet sont à votre disposition pour créer des estrades de différentes dimensions, en mesure d'exposer les produits euro3plast!



**telo khilia**

hanging banner  
 banner • lona • toile tendue

collection		gloss		light	
art. ET263	(cm. 60 x 185 h.)	art. ET264	(cm. 60 x 185 h.)	art. ET265	(cm. 60 x 185 h.)
art. ET243	(cm. 150 x 185 h.)	art. ET244	(cm. 150 x 185 h.)	art. ET245	(cm. 150 x 185 h.)
art. ET240	(cm. 240 x 300 h.)	art. ET241	(cm. 240 x 300 h.)	art. ET242	(cm. 240 x 300 h.)



**cover pallet**

art. ET225 (cm. 121 x 81 x 14 h.)



**totem khilia**

collection		gloss		light	
art. ET215	(cm. 50 x 154 h.)	art. ET214	(cm. 50 x 154 h.)	art. ET216	(cm. 50 x 154 h.)

# khilia collection





# khilia collection







# khilia mini

---





# khilia gloss

---



# khilia light





# khilia collection

---

dati tecnici

technical data

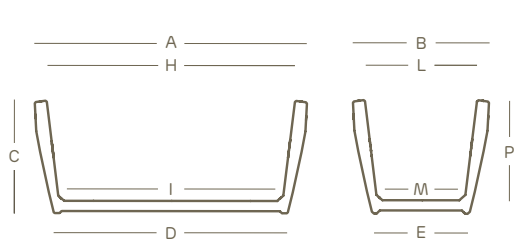

Art. 2465  
cm. 80

A	cm. 80	H	cm. 73
B	cm. 40	I	cm. 65
C	cm. 33	L	cm. 33
D	cm. 69	M	cm. 25
E	cm. 28	P	cm. 29

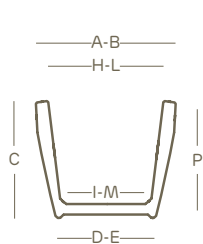

Art. 2486  
cm. 40

Art. 2494  
cm. 50

A-B	cm. 40	A-B	cm. 50
C	cm. 33	C	cm. 42
D-E	cm. 28	D-E	cm. 35
H-L	cm. 33	H-L	cm. 41
I-M	cm. 25	I-M	cm. 32
P	cm. 29	P	cm. 38

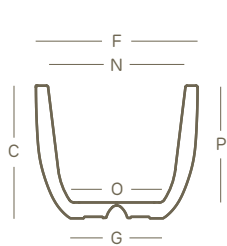

Art. 2903  
ø cm. 18

Art. 2453  
ø cm. 24

Art. 2318  
ø cm. 34

Art. 2319  
ø cm. 44

Art. 2320  
ø cm. 54

Art. 2447  
ø cm. 64

Art. 2454  
ø cm. 74

C	cm. 14	C	cm. 20	C	cm. 28	C	cm. 36	C	cm. 44	C	cm. 52	C	cm. 61
F	cm. 18	F	cm. 24	F	cm. 34	F	cm. 44	F	cm. 54	F	cm. 64	F	cm. 74
G	cm. 11	G	cm. 14	G	cm. 19	G	cm. 25	G	cm. 31	G	cm. 37	G	cm. 43
N	cm. 15	N	cm. 20	N	cm. 29	N	cm. 37	N	cm. 46	N	cm. 54	N	cm. 63
O	cm. 10	O	cm. 13	O	cm. 19	O	cm. 26	O	cm. 33	O	cm. 37	O	cm. 42
P	cm. 12	P	cm. 18	P	cm. 25	P	cm. 32	P	cm. 39	P	cm. 46	P	cm. 53

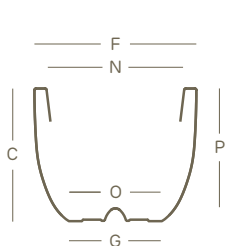

Art. 2904  
ø cm. 18

Art. 2860  
ø cm. 24

Art. 2861  
ø cm. 34

Art. 2862  
ø cm. 44

Art. 2863  
ø cm. 54

Art. 2864  
ø cm. 64

Art. 2865  
ø cm. 74

C	cm. 14	C	cm. 20	C	cm. 28	C	cm. 36	C	cm. 44	C	cm. 52	C	cm. 61
F	cm. 18	F	cm. 24	F	cm. 34	F	cm. 44	F	cm. 54	F	cm. 64	F	cm. 74
G	cm. 11	G	cm. 14	G	cm. 19	G	cm. 25	G	cm. 31	G	cm. 37	G	cm. 43
N	cm. 15	N	cm. 20	N	cm. 29	N	cm. 37	N	cm. 46	N	cm. 54	N	cm. 63
O	cm. 10	O	cm. 13	O	cm. 19	O	cm. 26	O	cm. 33	O	cm. 37	O	cm. 42
P	cm. 12	P	cm. 18	P	cm. 25	P	cm. 32	P	cm. 39	P	cm. 46	P	cm. 53



# icle

pag. 30



Art. 2390	Art. 2391
ø cm. 100	ø cm. 120
C cm. 97	C cm. 117
F cm. 19	F cm. 20
G cm. 9	G cm. 10
N cm. 3	N cm. 4

# ilie

pag. 10

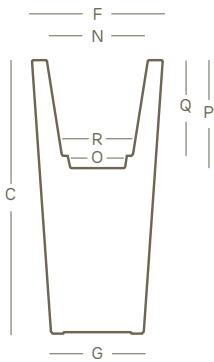

Art. 2497	Art. 2498	Art. 2415	Art. 2506
ø cm. 37	ø cm. 42	ø cm. 47	ø cm. 57
C cm. 75	C cm. 90	C cm. 98	C cm. 126
F cm. 37	F cm. 42	F cm. 47	F cm. 57
G cm. 26	G cm. 29	G cm. 33	G cm. 40
N cm. 28	N cm. 33	N cm. 36	N cm. 44
O cm. 15	O cm. 24	O cm. 20	O cm. 28
P cm. 33	P cm. 31	P cm. 41	P cm. 50
Q cm. 27		Q cm. 35	Q cm. 44
R cm. 20		R cm. 25	R cm. 32

# ikon

pag. 6

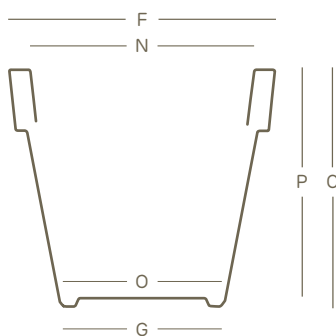

Art. 2603	Art. 2604	Art. 2605	Art. 2896	Art. 2541
ø cm. 40	ø cm. 50	ø cm. 60	ø cm. 70	ø cm. 80
C cm. 36	C cm. 44	C cm. 53	C cm. 62	C cm. 71
F cm. 40	F cm. 50	F cm. 60	F cm. 70	F cm. 80
G cm. 23	G cm. 29	G cm. 35	G cm. 42	G cm. 47
N cm. 34	N cm. 43	N cm. 52	N cm. 60	N cm. 69
O cm. 25	O cm. 30	O cm. 36	O cm. 41	O cm. 50
P cm. 33	P cm. 42	P cm. 51	P cm. 59	P cm. 70

# ikon

pag. 6

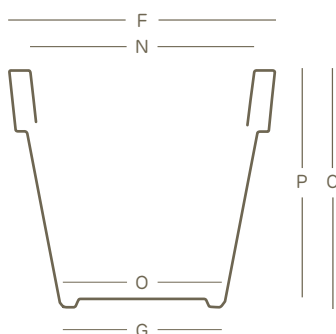

Art. 2542	Art. 2543	Art. 2786	Art. 2787
ø cm. 100	ø cm. 120	ø cm. 140	ø cm. 160
C cm. 89	C cm. 107	C cm. 125	C cm. 143
F cm. 100	F cm. 120	F cm. 140	F cm. 160
G cm. 59	G cm. 72	G cm. 85	G cm. 97
N cm. 86	N cm. 103	N cm. 120	N cm. 138
O cm. 61	O cm. 72	O cm. 83	O cm. 95
P cm. 88	P cm. 106	P cm. 124	P cm. 142

# kiam

pag. 12

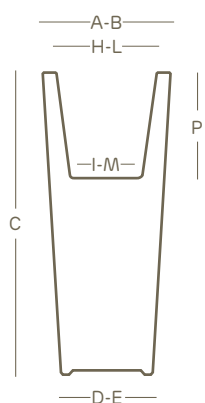

Art. 2499 cm. 35      Art. 2500 cm. 40

A-B	cm. 35	A-B	cm. 40
C	cm. 75	C	cm. 90
D-E	cm. 25	D-E	cm. 28
H-L	cm. 26	H-L	cm. 30
I-M	cm. 20	I-M	cm. 23
P	cm. 24	P	cm. 28

# kube cassetta • plant box

pag. 34

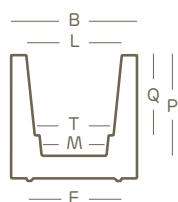
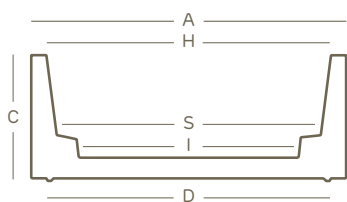

Art. 2601 cm. 80

Art. 2548 cm. 100

A	cm. 80	L	cm. 22	A	cm. 100	L	cm. 30
B	cm. 30	M	cm. 14	B	cm. 40	M	cm. 19
C	cm. 30	P	cm. 25	C	cm. 40	P	cm. 34
D	cm. 72	Q	cm. 19	D	cm. 90	Q	cm. 28
E	cm. 22	S	cm. 51	E	cm. 29	S	cm. 24
H	cm. 73	T	cm. 17	H	cm. 90	T	cm. 72
I	cm. 49			I	cm. 70		

# kube panca • bench

pag. 50

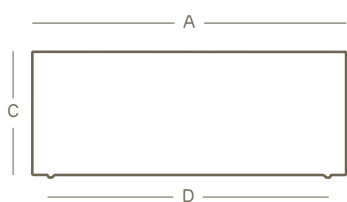

Art. 2549 cm. 100

A	cm. 100
B	cm. 40
C	cm. 40
D	cm. 90
E	cm. 29

# kube sgabello • stool

pag. 51

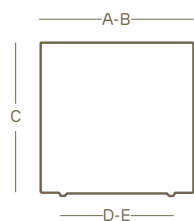

Art. 2532 cm. 40      Art. 2533 cm. 50

A	cm. 40	A	cm. 50
B	cm. 40	B	cm. 50
C	cm. 40	C	cm. 50
D	cm. 29	D	cm. 37
E	cm. 29	E	cm. 37

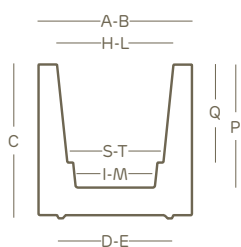

Art. 2538	Art. 2514	Art. 2515
cm. 30	cm. 40	cm. 50
A-B cm. 30	A-B cm. 40	A-B cm. 50
C cm. 30	C cm. 40	C cm. 50
D-E cm. 22	D-E cm. 29	D-E cm. 37
H-L cm. 23	H-L cm. 30	H-L cm. 38
I-M cm. 14	I-M cm. 19	I-M cm. 25
P cm. 25	P cm. 32	P cm. 40
Q cm. 18	Q cm. 26	Q cm. 34
S-T cm. 17	S-T cm. 24	S-T cm. 30

kube high cassetta alta • high plant box

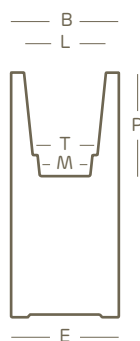
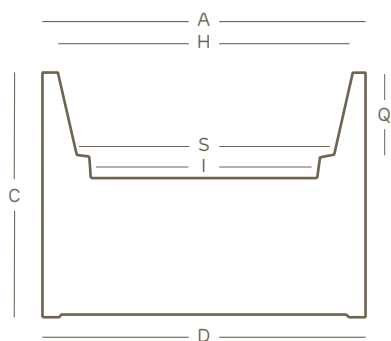

Art. 2602	Art. 2586
cm. 80	cm. 100
A cm. 80	A cm. 100
B cm. 30	B cm. 40
C cm. 70	C cm. 70
D cm. 80	D cm. 100
E cm. 30	E cm. 40
H cm. 73	H cm. 90
I cm. 49	I cm. 70
L cm. 22	L cm. 30
M cm. 14	M cm. 19
P cm. 25	P cm. 34
Q cm. 19	Q cm. 30
S cm. 51	S cm. 72
T cm. 17	T cm. 24

kube high vaso alto • high pot



Art. 2611	Art. 2612
cm. 30	cm. 40
A-B cm. 30	A-B cm. 40
C cm. 70	C cm. 70
D-E cm. 29	D-E cm. 39
H-L cm. 23	H-L cm. 30
I-M cm. 14	I-M cm. 19
P cm. 25	P cm. 33
Q cm. 18	Q cm. 26
S-T cm. 17	S-T cm. 24

kube high slim cassetta alta • high plant box

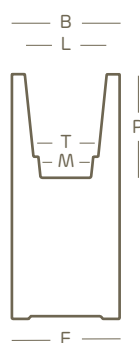
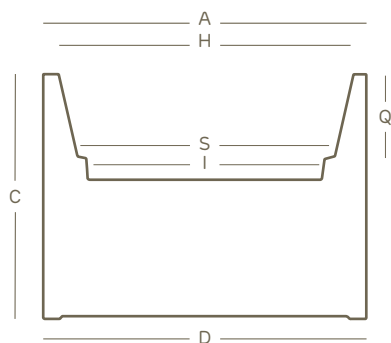

Art. 2777
cm. 80
A cm. 80
B cm. 25
C cm. 70
D cm. 80
E cm. 25
H cm. 75
I cm. 49
L cm. 20
M cm. 14
P cm. 26,5
Q cm. 20
S cm. 68
T cm. 18

## kube high slim modulo • module

pag. 46

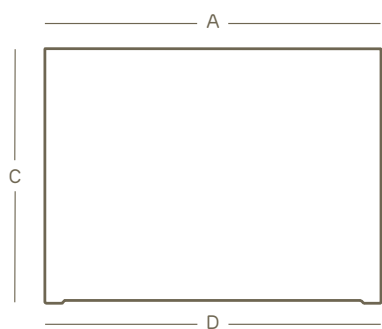

Art. 2789  
cm. 80

A cm. 80  
B cm. 25  
C cm. 70  
D cm. 80  
E cm. 25

## kube high slim modulo • module

pag. 46



Art. 2790  
cm. 25

A-B cm. 25  
C cm. 70  
D-E cm. 25

## kube high slim vaso alto • high pot

pag. 42

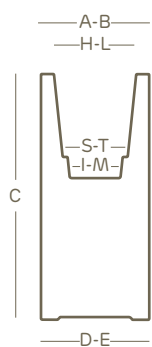

Art. 2788  
cm. 25

A-B cm. 25  
C cm. 70  
D-E cm. 25  
H-L cm. 20  
I-M cm. 14  
P cm. 26,5  
Q cm. 20  
S-T cm. 18

## kube tower cassetta alta • high plant box

pag. 49

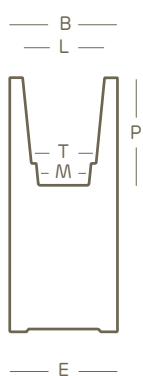
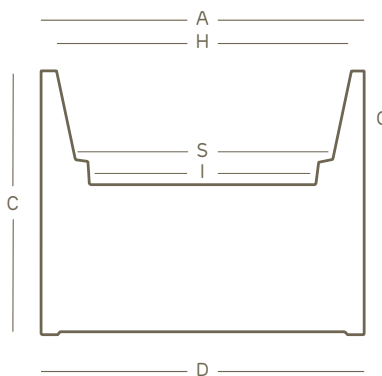

Art. 2825  
cm. 70

A cm. 70  
B cm. 30  
C cm. 90  
D cm. 70  
E cm. 30  
H cm. 63  
I cm. 49,5  
L cm. 23  
M cm. 14  
P cm. 26,5  
Q cm. 20  
S cm. 53  
T cm. 20

# kube tower vaso alto • high pot

pag. 48

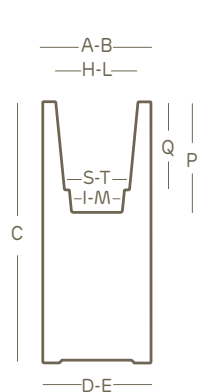

Art. 2826  
cm. 30

A-B cm. 30  
C cm. 90  
D-E cm. 30  
H-L cm. 23  
I-M cm. 14  
P cm. 26,5  
Q cm. 20  
S-T cm. 18

# misia

pag. 31

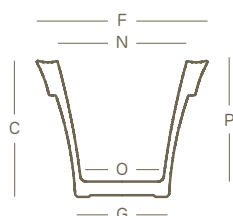

	Art. 2461 ø cm. 30	Art. 2416 ø cm. 40	Art. 2417 ø cm. 50	Art. 2418 ø cm. 60	Art. 2445 ø cm. 70	Art. 2446 ø cm. 80	Art. 2460 ø cm. 90
C	cm. 24	cm. 32	cm. 40	cm. 48	cm. 56	cm. 64	cm. 72
F	cm. 30	cm. 40	cm. 50	cm. 60	cm. 70	cm. 80	cm. 90
G	cm. 16	cm. 21	cm. 27	cm. 32	cm. 37	cm. 43	cm. 48
N	cm. 23	cm. 30	cm. 38	cm. 46	cm. 53	cm. 61	cm. 68
O	cm. 14	cm. 19	cm. 23	cm. 28	cm. 33	cm. 37	cm. 42
P	cm. 21	cm. 28	cm. 35	cm. 42	cm. 49	cm. 56	cm. 64

# niscal

pag. 24

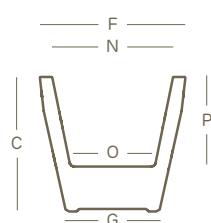

	Art. 2496 ø cm. 37	Art. 2484 ø cm. 47	Art. 2485 ø cm. 57
C	cm. 34	cm. 43	cm. 53
F	cm. 37	cm. 47	cm. 57
G	cm. 22	cm. 31	cm. 37
N	cm. 31	cm. 39	cm. 47
O	cm. 19	cm. 24	cm. 29
P	cm. 23	cm. 28	cm. 35

# opus

pag. 28

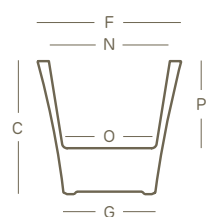

	Art. 2495 ø cm. 37	Art. 2482 ø cm. 47	Art. 2483 ø cm. 57
C	cm. 34	cm. 43	cm. 53
F	cm. 37	cm. 47	cm. 57
G	cm. 22	cm. 30	cm. 36
N	cm. 31	cm. 39	cm. 47
O	cm. 21	cm. 30	cm. 36
P	cm. 26	cm. 28	cm. 34

# quadrum

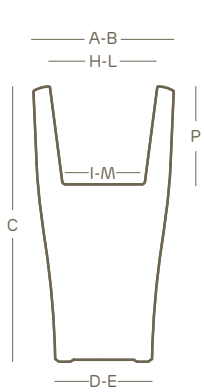

Art. 2419    Art. 2420  
cm. 37        cm. 51

A-B	cm. 37	A-B	cm. 51
C	cm. 73	C	cm. 100
D-E	cm. 26	D-E	cm. 35
H-L	cm. 29	H-L	cm. 39
I-M	cm. 22	I-M	cm. 30
P	cm. 27	P	cm. 35

# tulum

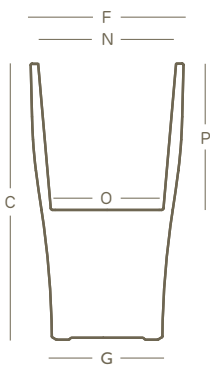

Art. 2373	Art. 2374	Art. 2375
ø cm. 35	ø cm. 43	ø cm. 56

C	cm. 51	C	cm. 63	C	cm. 102
F	cm. 35	F	cm. 43	F	cm. 56
G	cm. 24	G	cm. 29	G	cm. 41
N	cm. 32	N	cm. 39	N	cm. 51
O	cm. 25	O	cm. 30	O	cm. 42
P	cm. 29	P	cm. 35	P	cm. 54

# khilia mini

---

dati tecnici

technical data

# mini ikon

pag. 62

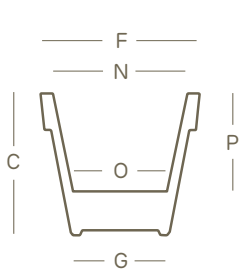

Art. 2635  
 ø cm. 20

C cm. 17,5  
 F cm. 20  
 G cm. 11,5  
 N cm. 16  
 O cm. 11  
 P cm. 12

# mini kube vaso • pot

pag. 64

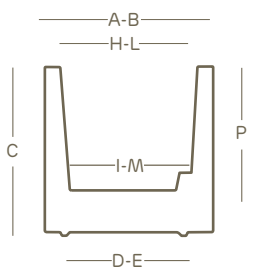

Art. 2827  
 cm. 18

Art. 2634  
 cm. 20

A-B cm. 18	A-B cm. 20
C cm. 18	C cm. 20
D-E cm. 14	D-E cm. 15
H-L cm. 15	H-L cm. 15
I-M cm. 13	I-M cm. 12
P cm. 14	P cm. 14,5

# mini kube vaso con riserva d'acqua • pot with water reserve

pag. 70

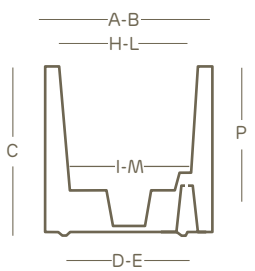

Art. 2853  
 cm. 18

A-B cm. 18  
 C cm. 18  
 D-E cm. 14  
 H-L cm. 15  
 I-M cm. 13  
 P cm. 14

# mini kube cassetta • plant box

pag. 66

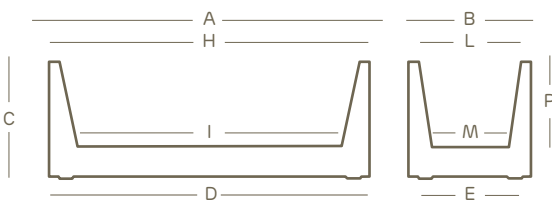

Art. 2828  
 cm. 50

Art. 2776  
 cm. 60

A cm. 50	A cm. 60
B cm. 18	B cm. 20
C cm. 18	C cm. 20
D cm. 46	D cm. 55
E cm. 14	E cm. 14,5
H cm. 47	H cm. 55
I cm. 40,5	I cm. 52
L cm. 15	L cm. 15
M cm. 13	M cm. 13
P cm. 14	P cm. 15,5



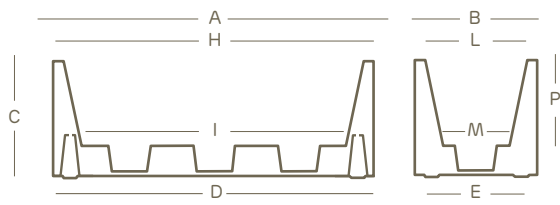

Art. 2852  
cm. 50

- A cm. 50
- B cm. 18
- C cm. 18
- D cm. 46
- E cm. 14
- H cm. 47
- I cm. 40,5
- L cm. 15
- M cm. 13
- P cm. 14



# khilia gloss

---

dati tecnici

technical data

## ilie gloss

pag. 76

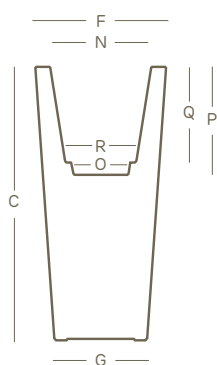

Art. 2640	Art. 2579	Art. 2509	Art. 2518	Art. 2580
ø cm. 27	ø cm. 32	ø cm. 37	ø cm. 47	ø cm. 57
C cm. 56	C cm. 67	C cm. 75	C cm. 98	C cm. 126
F cm. 27	F cm. 32	F cm. 37	F cm. 47	F cm. 57
G cm. 19	G cm. 23	G cm. 26	G cm. 33	G cm. 40
N cm. 20	N cm. 24	N cm. 28	N cm. 36	N cm. 44
O cm. 15	O cm. 15	O cm. 15	O cm. 20	O cm. 28
P cm. 19	P cm. 29	P cm. 33	P cm. 41	P cm. 50
Q cm. 15	Q cm. 23	Q cm. 27	Q cm. 35	Q cm. 44
R cm. 16	R cm. 18	R cm. 20	R cm. 25	R cm. 32

## kiam gloss

pag. 77

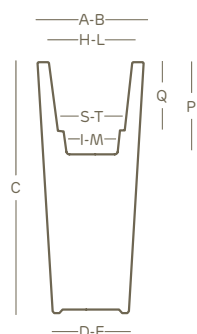

Art. 2637	Art. 2581	Art. 2638	Art. 2582
cm. 25	cm. 30	cm. 35	cm. 40
A-B cm. 25	A-B cm. 30	A-B cm. 35	A-B cm. 40
C cm. 56	C cm. 67	C cm. 75	C cm. 90
D-E cm. 18	D-E cm. 21	D-E cm. 26	D-E cm. 28
H-L cm. 18	H-L cm. 22	H-L cm. 26	H-L cm. 30
I-M cm. 13	I-M cm. 14	I-M cm. 14	I-M cm. 21
P cm. 17	P cm. 26	P cm. 31	P cm. 33
Q cm. 13	Q cm. 19	Q cm. 24	Q cm. 27
S-T cm. 15	S-T cm. 17	S-T cm. 17	S-T cm. 24

## kube gloss vaso • pot

pag. 74

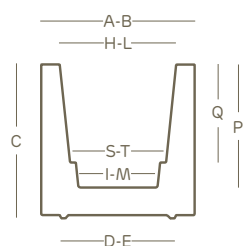

Art. 2583	Art. 2584	Art. 2585
cm. 30	cm. 40	cm. 50
A-B cm. 30	A-B cm. 40	A-B cm. 50
C cm. 30	C cm. 40	C cm. 50
D-E cm. 22	D-E cm. 29	D-E cm. 37
H-L cm. 23	H-L cm. 30	H-L cm. 38
I-M cm. 14	I-M cm. 19	I-M cm. 25
P cm. 25	P cm. 33	P cm. 41
Q cm. 18	Q cm. 27	Q cm. 35
S-T cm. 17	S-T cm. 24	S-T cm. 30

## kuno gloss

pag. 78

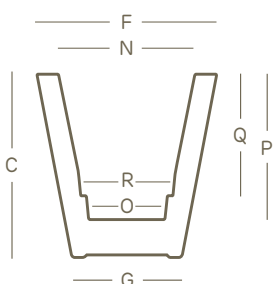

Art. 2536	Art. 2534	Art. 2535
ø cm. 40	ø cm. 50	ø cm. 60
C cm. 40	C cm. 50	C cm. 60
F cm. 40	F cm. 50	F cm. 60
G cm. 24	G cm. 30	G cm. 37
N cm. 30	N cm. 38	N cm. 46
O cm. 17	O cm. 21	O cm. 28
P cm. 32	P cm. 40	P cm. 48
Q cm. 26	Q cm. 36	Q cm. 42
R cm. 20	R cm. 25	R cm. 32

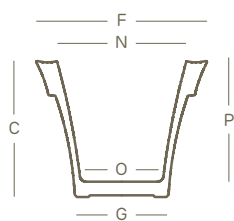

	Art. 2464	Art. 2487	Art. 2488
	ø cm. 40	ø cm. 50	ø cm. 60
C	cm. 32	cm. 40	cm. 48
F	cm. 40	cm. 50	cm. 60
G	cm. 21	cm. 27	cm. 32
N	cm. 30	cm. 38	cm. 46
O	cm. 19	cm. 23	cm. 28
P	cm. 28	cm. 35	cm. 42



# khilia laccati

---

dati tecnici

technical data

## ilie laccato • lacquered

pag. 84

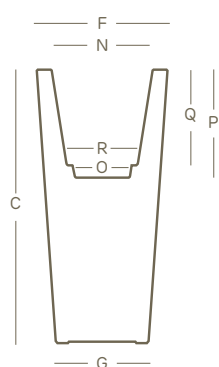

Art. L2497	Art. L2498	Art. L2415	Art. L2506
ø cm. 37	ø cm. 42	ø cm. 47	ø cm. 57
C cm. 75	C cm. 90	C cm. 98	C cm. 126
F cm. 37	F cm. 42	F cm. 47	F cm. 57
G cm. 26	G cm. 29	G cm. 33	G cm. 40
N cm. 28	N cm. 33	N cm. 36	N cm. 44
O cm. 15	O cm. 24	O cm. 20	O cm. 28
P cm. 33	P cm. 31	P cm. 41	P cm. 50
Q cm. 27		Q cm. 35	Q cm. 44
R cm. 20		R cm. 25	R cm. 32

## ikon laccato • lacquered

pag. 86

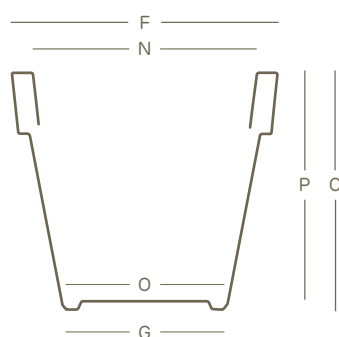

Art. L2603	Art. L2604	Art. L2605	Art. L2896	Art. L2541
ø cm. 40	ø cm. 50	ø cm. 60	ø cm. 70	ø cm. 80
C cm. 36	C cm. 44	C cm. 53	C cm. 62	C cm. 71
F cm. 40	F cm. 50	F cm. 60	F cm. 70	F cm. 80
G cm. 23	G cm. 29	G cm. 35	G cm. 42	G cm. 47
N cm. 34	N cm. 43	N cm. 52	N cm. 60	N cm. 69
O cm. 25	O cm. 30	O cm. 36	O cm. 41	O cm. 50
P cm. 33	P cm. 42	P cm. 51	P cm. 59	P cm. 70

## ikon laccato • lacquered

pag. 86

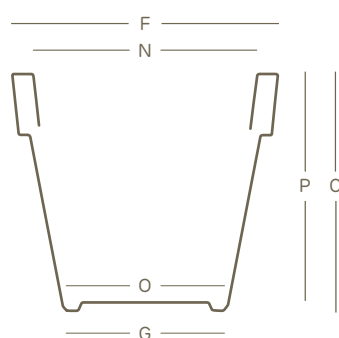

Art. L2542	Art. L2543	Art. L2786	Art. L2787
ø cm. 100	ø cm. 120	ø cm. 140	ø cm. 160
C cm. 89	C cm. 107	C cm. 125	C cm. 143
F cm. 100	F cm. 120	F cm. 140	F cm. 160
G cm. 59	G cm. 72	G cm. 85	G cm. 97
N cm. 86	N cm. 103	N cm. 120	N cm. 138
O cm. 61	O cm. 72	O cm. 83	O cm. 95
P cm. 88	P cm. 106	P cm. 124	P cm. 142

## quadrum laccato • lacquered

pag. 85

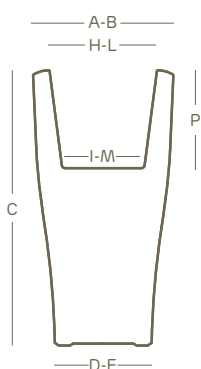

Art. L2419	Art. L2420
cm. 37	cm. 51
A-B cm. 37	A-B cm. 51
C cm. 73	C cm. 100
D-E cm. 26	D-E cm. 35
H-L cm. 29	H-L cm. 39
I-M cm. 22	I-M cm. 30
P cm. 27	P cm. 35





# Legenda / Legend



Lampada fluorescente MAX 1 x 60 W  
Fluorescent lamp MAX 1 x 60 W



Classe di isolamento: Classe II.  
Con doppio isolamento e/o rinforzo in ogni parte e senza dispositivi per la messa a terra.  
Insulation class: Class II.  
With double insulation and/or reinforcement in each part and without ground devices.



Attesta la conformità del prodotto alle disposizioni delle direttive comunitarie.  
It certifies the conformity of the product to the European community instructions.

IP 20

Prodotto con nessuna protezione nei confronti della penetrazione dell'acqua.  
L'utente non ha comunque modo di entrare fisicamente in contatto con parti in tensione.  
Product not protected against penetration of water.  
Nevertheless, the user does not come into physical contact with the parts under tension.

IP 67

Prodotto resistente all'immersione temporanea.  
L'icona, dove presente, fa riferimento al corpo lampada.  
The product is temporary immersion proof.  
When showed, the icon refers to the lamp body.

IP 68

Protezione totale alla penetrazione di corpi solidi e polveri. Protezione contro l'immersione in acqua permanente a 1 metro di profondità.  
Total protection against penetration of solid bodies and dust. Protected from continuous immersion in water 1 meter deep.



Ai sensi della Direttiva 2012/19/UE, il prodotto, alla fine della sua vita utile, non deve essere smaltito come rifiuto urbano.  
According to the Directive 2012/19/UE, once the device life time is ended, it must not be disposed as urban waste.

Tutte le apparecchiature elettriche sono conformi alle direttive 2011/65/UE sulle Restrizioni d'uso di alcune sostanze pericolose (RoHS), recepite in Italia con il D.lgs 04/03/2014 n.27.

All electric equipments meet the Directives 2011/65/UE about the Reduction of the use of certain Hazardous Substances (RoHS), which came into force in Italy with D. lgs 04/03/2014 n.27.

## Avvertenze - Warning:

- Collegare la spina dell'apparecchio in una presa collocata in un luogo protetto dalla pioggia e dagli spruzzi d'acqua.
- Se il cavo flessibile esterno di questo apparecchio viene danneggiato, deve essere sostituito esclusivamente dal costruttore, dal suo servizio di assistenza, o da personale qualificato equivalente, al fine di evitare pericoli.
- Nelle versioni sprovviste di interruttore sul cavo di alimentazione, collegare la spina dell'apparecchio sotto una presa comandata da interruttore.
- Connect the plug of the appliance to a power outlet that is located in a sheltered position, protected from rain and water splashes.
- If the external flexible cable of this appliance is damaged it must be replaced by either the manufacturer, the manufacturer's customer assistance service or by equivalent qualified personnel, in order to prevent possible hazards.
- For models that are not equipped with an inline on/off switch, connect the plug of the appliance to a switch controlled outlet.

# khilia lights

---

dati tecnici

technical data

## ikon light indoor

pag. 100

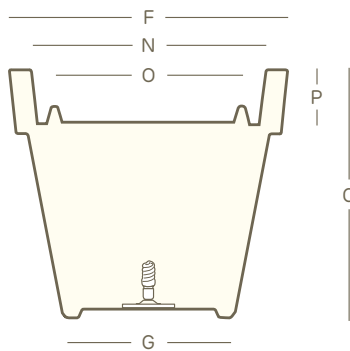

Art. 2721	Art. 2725	Art. 2729	Art. 2899	Art. 2641
ø cm. 40	ø cm. 50	ø cm. 60	ø cm. 70	ø cm. 80
C cm. 36	C cm. 44	C cm. 53	C cm. 62	C cm. 71
F cm. 40	F cm. 50	F cm. 60	F cm. 70	F cm. 80
G cm. 23	G cm. 29	G cm. 35	G cm. 42	G cm. 47
N cm. 34	N cm. 43	N cm. 52	N cm. 60	N cm. 69
O cm. 25	O cm. 30	O cm. 37	O cm. 44	O cm. 50
P cm. 6,7	P cm. 8,4	P cm. 10	P cm. 12	P cm. 13

## ikon light indoor

pag. 100

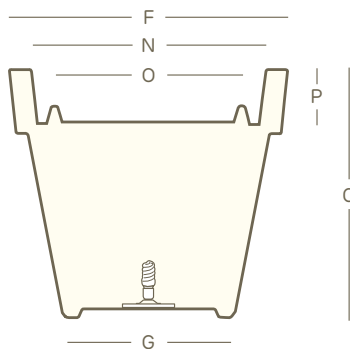

Art. 2653	Art. 2657	Art. 2806	Art. 2810
ø cm. 100	ø cm. 120	ø cm. 140	ø cm. 160
C cm. 89	C cm. 107	C cm. 125	C cm. 143
F cm. 100	F cm. 120	F cm. 140	F cm. 160
G cm. 59	G cm. 72	G cm. 85	G cm. 97
N cm. 86	N cm. 103	N cm. 120	N cm. 138
O cm. 62	O cm. 75	O cm. 87	O cm. 100
P cm. 18	P cm. 22	P cm. 29	P cm. 33

## ikon rgb led light indoor

pag. 100

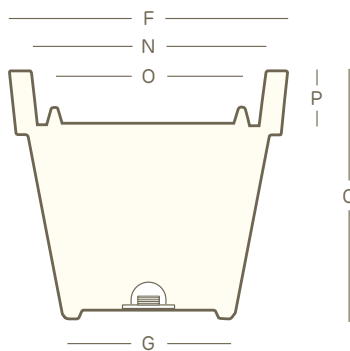

Art. 2723	Art. 2727	Art. 2731	Art. 2901	Art. 2643
ø cm. 40	ø cm. 50	ø cm. 60	ø cm. 70	ø cm. 80
C cm. 36	C cm. 44	C cm. 53	C cm. 62	C cm. 71
F cm. 40	F cm. 50	F cm. 60	F cm. 70	F cm. 80
G cm. 23	G cm. 29	G cm. 35	G cm. 42	G cm. 47
N cm. 34	N cm. 43	N cm. 52	N cm. 60	N cm. 69
O cm. 25	O cm. 30	O cm. 37	O cm. 44	O cm. 50
P cm. 6,7	P cm. 8,4	P cm. 10	P cm. 12	P cm. 13

## ikon rgb led light indoor

pag. 100

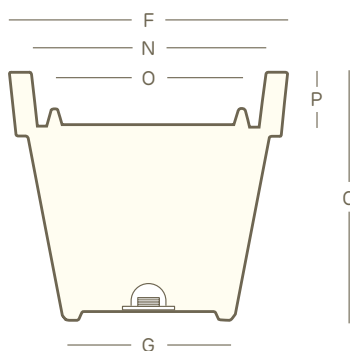

Art. 2655	Art. 2659	Art. 2808	Art. 2812
ø cm. 100	ø cm. 120	ø cm. 140	ø cm. 160
C cm. 89	C cm. 107	C cm. 125	C cm. 143
F cm. 100	F cm. 120	F cm. 140	F cm. 160
G cm. 59	G cm. 72	G cm. 85	G cm. 97
N cm. 86	N cm. 103	N cm. 120	N cm. 138
O cm. 62	O cm. 75	O cm. 87	O cm. 100
P cm. 18	P cm. 22	P cm. 29	P cm. 33

## ikon light outdoor

pag. 100

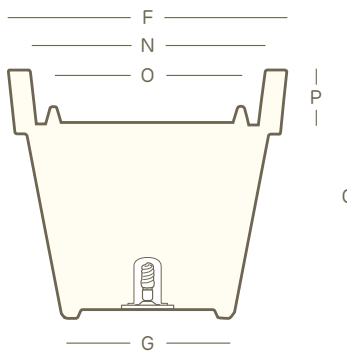

Art. 2722 ø cm. 40	Art. 2726 ø cm. 50	Art. 2730 ø cm. 60	Art. 2900 ø cm. 70	Art. 2642 ø cm. 80
C cm. 36	C cm. 44	C cm. 53	C cm. 62	C cm. 71
F cm. 40	F cm. 50	F cm. 60	F cm. 70	F cm. 80
G cm. 23	G cm. 29	G cm. 35	G cm. 42	G cm. 47
N cm. 34	N cm. 43	N cm. 52	N cm. 60	N cm. 69
O cm. 25	O cm. 30	O cm. 37	O cm. 44	O cm. 50
P cm. 6,7	P cm. 8,4	P cm. 10	P cm. 12	P cm. 13

## ikon light outdoor

pag. 100

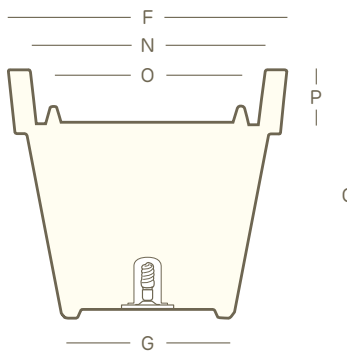

Art. 2654 ø cm. 100	Art. 2658 ø cm. 120	Art. 2807 ø cm. 140	Art. 2811 ø cm. 160
C cm. 89	C cm. 107	C cm. 125	C cm. 143
F cm. 100	F cm. 120	F cm. 140	F cm. 160
G cm. 59	G cm. 72	G cm. 85	G cm. 97
N cm. 86	N cm. 103	N cm. 120	N cm. 138
O cm. 62	O cm. 75	O cm. 87	O cm. 100
P cm. 18	P cm. 22	P cm. 29	P cm. 33

## ikon rgb led light outdoor

pag. 100

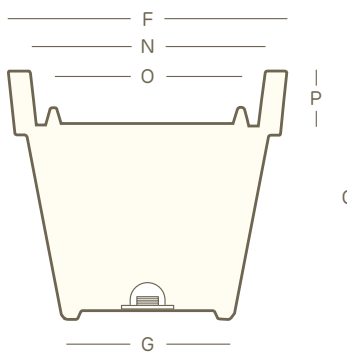

Art. 2724 ø cm. 40	Art. 2728 ø cm. 50	Art. 2732 ø cm. 60	Art. 2902 ø cm. 70	Art. 2644 ø cm. 80
C cm. 36	C cm. 44	C cm. 53	C cm. 62	C cm. 71
F cm. 40	F cm. 50	F cm. 60	F cm. 70	F cm. 80
G cm. 23	G cm. 29	G cm. 35	G cm. 42	G cm. 47
N cm. 34	N cm. 43	N cm. 52	N cm. 60	N cm. 69
O cm. 25	O cm. 30	O cm. 37	O cm. 44	O cm. 50
P cm. 6,7	P cm. 8,4	P cm. 10	P cm. 12	P cm. 13

## ikon rgb led light outdoor

pag. 100

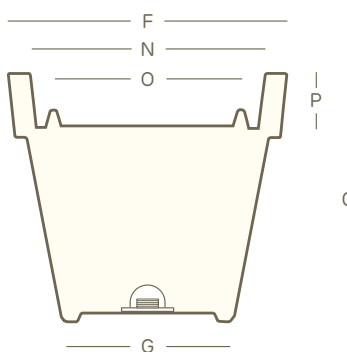

Art. 2656 ø cm. 100	Art. 2660 ø cm. 120	Art. 2809 ø cm. 140	Art. 2813 ø cm. 160
C cm. 89	C cm. 107	C cm. 125	C cm. 143
F cm. 100	F cm. 120	F cm. 140	F cm. 160
G cm. 59	G cm. 72	G cm. 85	G cm. 97
N cm. 86	N cm. 103	N cm. 120	N cm. 138
O cm. 62	O cm. 75	O cm. 87	O cm. 100
P cm. 18	P cm. 22	P cm. 29	P cm. 33

## ilie light indoor

pag. 95

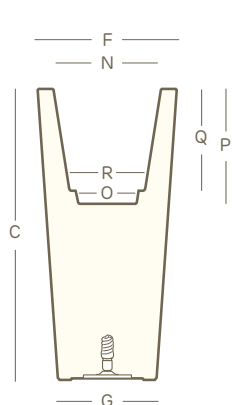

Art. 2661	Art. 2665	Art. 2669	Art. 2673
ø cm. 37	ø cm. 42	ø cm. 47	ø cm. 57
C cm. 75	C cm. 90	C cm. 98	C cm. 126
F cm. 37	F cm. 42	F cm. 47	F cm. 57
G cm. 26	G cm. 29	G cm. 33	G cm. 40
N cm. 28	N cm. 33	N cm. 36	N cm. 44
O cm. 15	O cm. 24	O cm. 20	O cm. 28
P cm. 33	P cm. 31	P cm. 41	P cm. 50
Q cm. 27		Q cm. 35	Q cm. 44
R cm. 20		R cm. 25	R cm. 32

## ilie rgb led light indoor

pag. 95

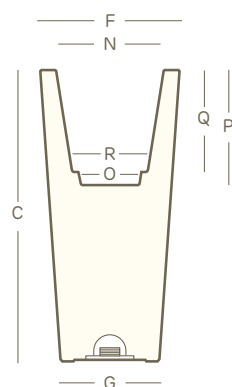

Art. 2663	Art. 2667	Art. 2671	Art. 2675
ø cm. 37	ø cm. 42	ø cm. 47	ø cm. 57
C cm. 75	C cm. 90	C cm. 98	C cm. 126
F cm. 37	F cm. 42	F cm. 47	F cm. 57
G cm. 26	G cm. 29	G cm. 33	G cm. 40
N cm. 28	N cm. 33	N cm. 36	N cm. 44
O cm. 15	O cm. 24	O cm. 20	O cm. 28
P cm. 33	P cm. 31	P cm. 41	P cm. 50
Q cm. 27		Q cm. 35	Q cm. 44
R cm. 20		R cm. 25	R cm. 32

## kiam light indoor

pag. 94

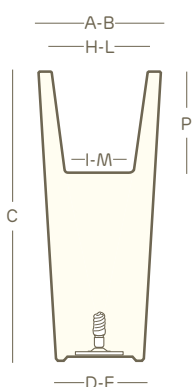

Art. 2693	Art. 2697
cm. 35	cm. 40
A-B cm. 35	A-B cm. 40
C cm. 75	C cm. 90
D-E cm. 25	D-E cm. 28
H-L cm. 26	H-L cm. 30
I-M cm. 20	I-M cm. 23
P cm. 24	P cm. 28

## kiam rgb led light indoor

pag. 94

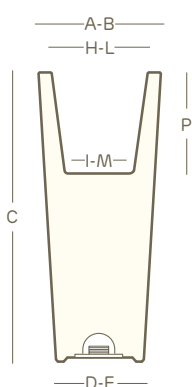

Art. 2695	Art. 2699
cm. 35	cm. 40
A-B cm. 35	A-B cm. 40
C cm. 75	C cm. 90
D-E cm. 25	D-E cm. 28
H-L cm. 26	H-L cm. 30
I-M cm. 20	I-M cm. 23
P cm. 24	P cm. 28

# ilie light outdoor

pag. 95

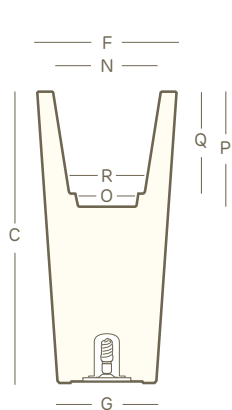

Art. 2662	Art. 2666	Art. 2670	Art. 2674
ø cm. 37	ø cm. 42	ø cm. 47	ø cm. 57
C cm. 75	C cm. 90	C cm. 98	C cm. 126
F cm. 37	F cm. 42	F cm. 47	F cm. 57
G cm. 26	G cm. 29	G cm. 33	G cm. 40
N cm. 28	N cm. 33	N cm. 36	N cm. 44
O cm. 15	O cm. 24	O cm. 20	O cm. 28
P cm. 33	P cm. 31	P cm. 41	P cm. 50
Q cm. 27		Q cm. 35	Q cm. 44
R cm. 20		R cm. 25	R cm. 32

# ilie rgb led light outdoor

pag. 95

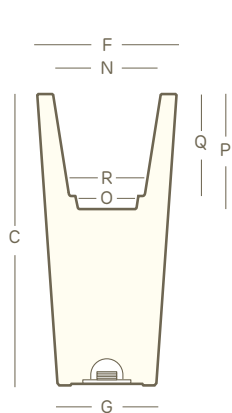

Art. 2664	Art. 2668	Art. 2672	Art. 2676
ø cm. 37	ø cm. 42	ø cm. 47	ø cm. 57
C cm. 75	C cm. 90	C cm. 98	C cm. 126
F cm. 37	F cm. 42	F cm. 47	F cm. 57
G cm. 26	G cm. 29	G cm. 33	G cm. 40
N cm. 28	N cm. 33	N cm. 36	N cm. 44
O cm. 15	O cm. 24	O cm. 20	O cm. 28
P cm. 33	P cm. 31	P cm. 41	P cm. 50
Q cm. 27		Q cm. 35	Q cm. 44
R cm. 20		R cm. 25	R cm. 32

# kiam light outdoor

pag. 94

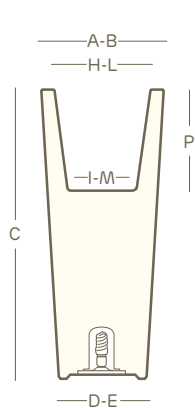

Art. 2694	Art. 2698
cm. 35	cm. 40
A-B cm. 35	A-B cm. 40
C cm. 75	C cm. 90
D-E cm. 25	D-E cm. 28
H-L cm. 26	H-L cm. 30
I-M cm. 20	I-M cm. 23
P cm. 24	P cm. 28

# kiam rgb led light outdoor

pag. 94

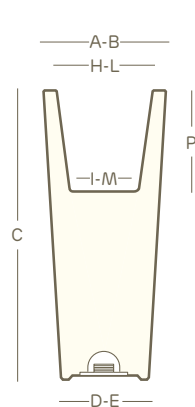

Art. 2696	Art. 2700
cm. 35	cm. 40
A-B cm. 35	A-B cm. 40
C cm. 75	C cm. 90
D-E cm. 25	D-E cm. 28
H-L cm. 26	H-L cm. 30
I-M cm. 20	I-M cm. 23
P cm. 24	P cm. 28

## kube light indoor sgabello • stool

pag. 90

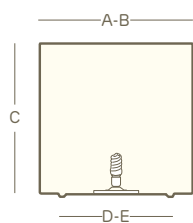

Art. 2705    Art. 2708  
cm. 40        cm. 50

A	cm. 40	A	cm. 50
B	cm. 40	B	cm. 50
C	cm. 40	C	cm. 50
D	cm. 29	D	cm. 37
E	cm. 29	E	cm. 37

## kube rgb led light indoor sgabello • stool

pag. 90

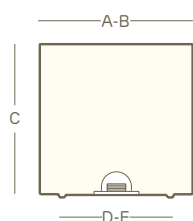

Art. 2707    Art. 2710  
cm. 40        cm. 50

A	cm. 40	A	cm. 50
B	cm. 40	B	cm. 50
C	cm. 40	C	cm. 50
D	cm. 29	D	cm. 37
E	cm. 29	E	cm. 37

## kube light indoor panca • bench

pag. 93

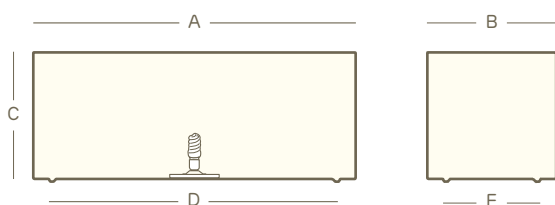

Art. 2755  
cm. 100

A	cm. 100
B	cm. 40
C	cm. 40
D	cm. 90
E	cm. 29

## kube rgb led light indoor panca • bench

pag. 93

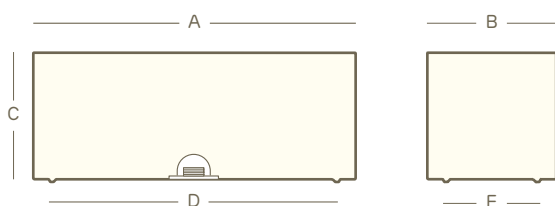

Art. 2757  
cm. 100

A	cm. 100
B	cm. 40
C	cm. 40
D	cm. 90
E	cm. 29



## kube light outdoor sgabello • stool

pag. 90

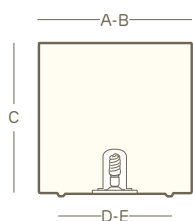

Art. 2706  
cm. 40

Art. 2709  
cm. 50

A	cm. 40	A	cm. 50
B	cm. 40	B	cm. 50
C	cm. 40	C	cm. 50
D	cm. 29	D	cm. 37
E	cm. 29	E	cm. 37

## kube rgb led light outdoor sgabello • stool

pag. 90

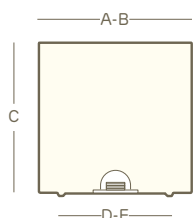

Art. 2707  
cm. 40

Art. 2710  
cm. 50

A	cm. 40	A	cm. 50
B	cm. 40	B	cm. 50
C	cm. 40	C	cm. 50
D	cm. 29	D	cm. 37
E	cm. 29	E	cm. 37

## kube light outdoor panca • bench

pag. 93

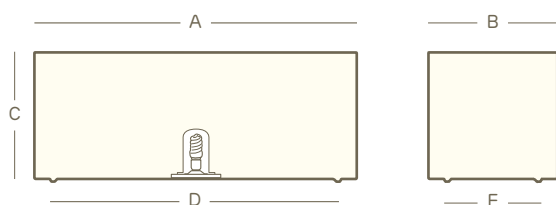

Art. 2756  
cm. 100

A	cm. 100
B	cm. 40
C	cm. 40
D	cm. 90
E	cm. 29

## kube rgb led light outdoor panca • bench

pag. 93

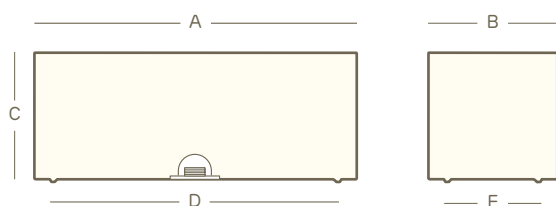

Art. 2757  
cm. 100

A	cm. 100
B	cm. 40
C	cm. 40
D	cm. 90
E	cm. 29

# kube high light indoor cassetta

pag. 101

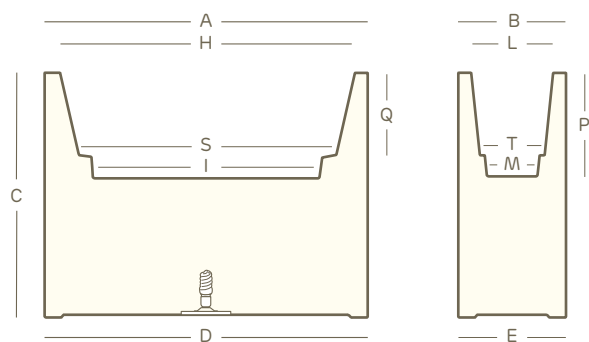

Art. 2745  
cm. 80

Art. 2701  
cm. 100

A	cm. 80	L	cm. 22	A	cm. 100	L	cm. 30
B	cm. 30	M	cm. 14	B	cm. 40	M	cm. 19
C	cm. 70	P	cm. 25	C	cm. 70	P	cm. 34
D	cm. 80	Q	cm. 19	D	cm. 100	Q	cm. 30
E	cm. 30	S	cm. 51	E	cm. 40	S	cm. 72
H	cm. 73	T	cm. 17	H	cm. 90	T	cm. 24
I	cm. 49			I	cm. 70		

# kube high rgb led light indoor cassetta

pag. 101

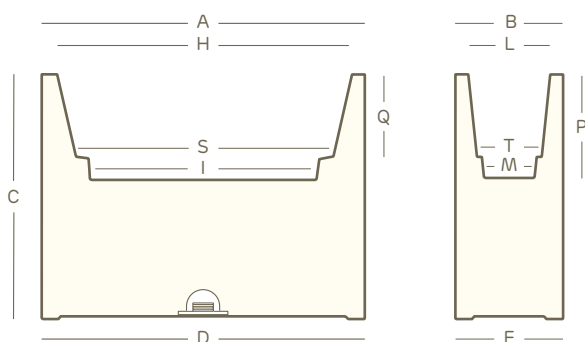

Art. 2747  
cm. 80

Art. 2703  
cm. 100

A	cm. 80	L	cm. 22	A	cm. 100	L	cm. 30
B	cm. 30	M	cm. 14	B	cm. 40	M	cm. 19
C	cm. 70	P	cm. 25	C	cm. 70	P	cm. 34
D	cm. 80	Q	cm. 19	D	cm. 100	Q	cm. 30
E	cm. 30	S	cm. 51	E	cm. 40	S	cm. 72
H	cm. 73	T	cm. 17	H	cm. 90	T	cm. 24
I	cm. 49			I	cm. 70		

# kube high light indoor vaso • pot

pag. 92

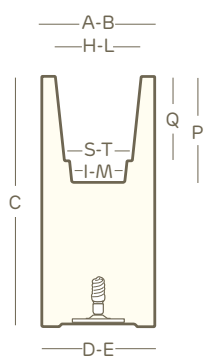

Art. 2737  
cm. 30

Art. 2741  
cm. 40

A-B	cm. 30	A-B	cm. 40
C	cm. 70	C	cm. 70
D-E	cm. 29	D-E	cm. 39
H-L	cm. 23	H-L	cm. 30
I-M	cm. 14	I-M	cm. 19
P	cm. 25	P	cm. 33
Q	cm. 18	Q	cm. 26
S-T	cm. 17	S-T	cm. 24

# kube high rgb led light indoor vaso • pot

pag. 92

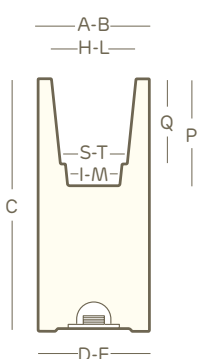

Art. 2739  
cm. 30

Art. 2743  
cm. 40

A-B	cm. 30	A-B	cm. 40
C	cm. 70	C	cm. 70
D-E	cm. 29	D-E	cm. 39
H-L	cm. 23	H-L	cm. 30
I-M	cm. 14	I-M	cm. 19
P	cm. 25	P	cm. 33
Q	cm. 18	Q	cm. 26
S-T	cm. 17	S-T	cm. 24

# kube high light outdoor cassetta

pag. 101

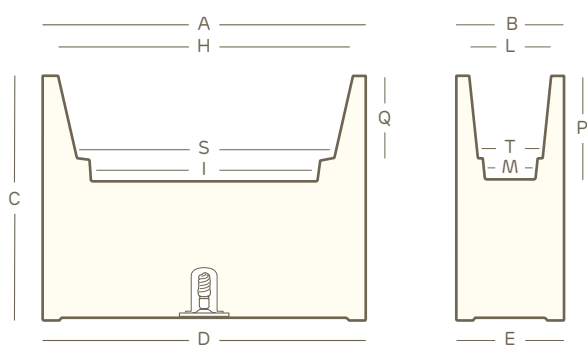

Art. 2746  
cm. 80

Art. 2702  
cm. 100

A	cm. 80	L	cm. 22	A	cm. 100	L	cm. 30
B	cm. 30	M	cm. 14	B	cm. 40	M	cm. 19
C	cm. 70	P	cm. 25	C	cm. 70	P	cm. 34
D	cm. 80	Q	cm. 19	D	cm. 100	Q	cm. 30
E	cm. 30	S	cm. 51	E	cm. 40	S	cm. 72
H	cm. 73	T	cm. 17	H	cm. 90	T	cm. 24
I	cm. 49			I	cm. 70		

# kube high rgb led light outdoor cassetta

pag. 101

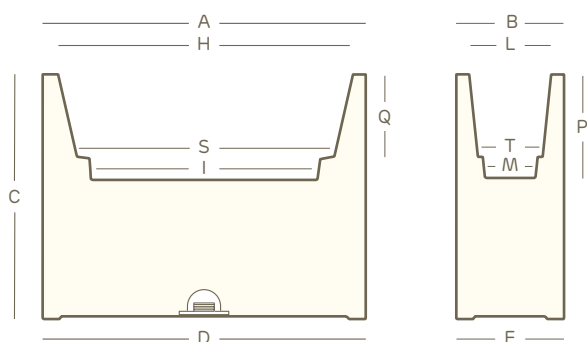

Art. 2748  
cm. 80

Art. 2704  
cm. 100

A	cm. 80	L	cm. 22	A	cm. 100	L	cm. 30
B	cm. 30	M	cm. 14	B	cm. 40	M	cm. 19
C	cm. 70	P	cm. 25	C	cm. 70	P	cm. 34
D	cm. 80	Q	cm. 19	D	cm. 100	Q	cm. 30
E	cm. 30	S	cm. 51	E	cm. 40	S	cm. 72
H	cm. 73	T	cm. 17	H	cm. 90	T	cm. 24
I	cm. 49			I	cm. 70		

# kube high light outdoor vaso • pot

pag. 92

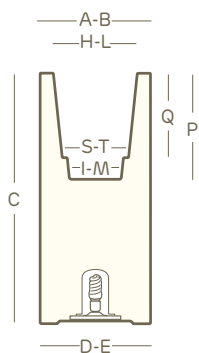

Art. 2738  
cm. 30

Art. 2742  
cm. 40

A-B	cm. 30	A-B	cm. 40
C	cm. 70	C	cm. 70
D-E	cm. 29	D-E	cm. 39
H-L	cm. 23	H-L	cm. 30
I-M	cm. 14	I-M	cm. 19
P	cm. 25	P	cm. 33
Q	cm. 18	Q	cm. 26
S-T	cm. 17	S-T	cm. 24

# kube high rgb led light outdoor vaso • pot

pag. 92

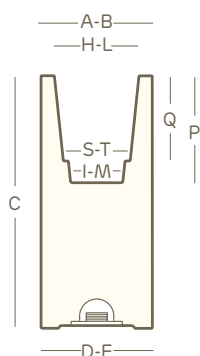

Art. 2740  
cm. 30

Art. 2744  
cm. 40

A-B	cm. 30	A-B	cm. 40
C	cm. 70	C	cm. 70
D-E	cm. 29	D-E	cm. 39
H-L	cm. 23	H-L	cm. 30
I-M	cm. 14	I-M	cm. 19
P	cm. 25	P	cm. 33
Q	cm. 18	Q	cm. 26
S-T	cm. 17	S-T	cm. 24

# kube high slim light indoor cassetta alta • high plant box

pag. 103

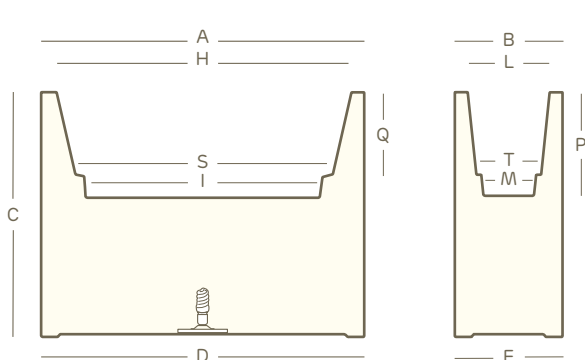

Art. 2792  
cm. 80

A	cm. 80	M	cm. 14
B	cm. 25	P	cm. 25
C	cm. 70	Q	cm. 20
D	cm. 80	S	cm. 68
E	cm. 25	T	cm. 18
H	cm. 75		
I	cm. 49		
L	cm. 20		

# kube high slim rgb led light indoor cassetta alta • high plant box

pag. 103

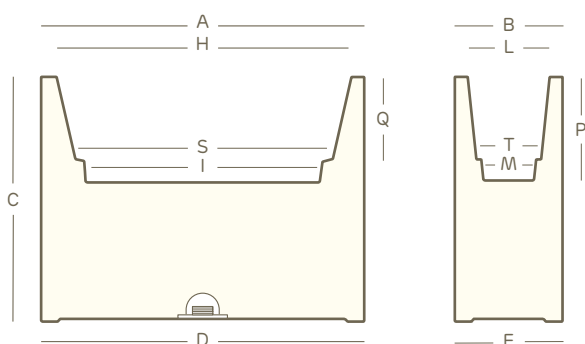

Art. 2794  
cm. 80

A	cm. 80	M	cm. 14
B	cm. 25	P	cm. 25
C	cm. 70	Q	cm. 20
D	cm. 80	S	cm. 68
E	cm. 25	T	cm. 18
H	cm. 75		
I	cm. 49		
L	cm. 20		

# kube high slim light indoor modulo • module

pag. 104

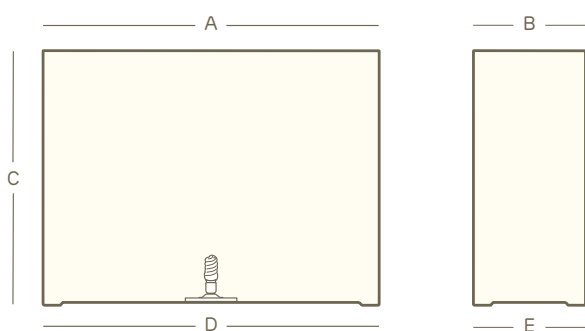

Art. 2803  
cm. 80

A	cm. 80
B	cm. 25
C	cm. 70
D	cm. 80
E	cm. 25

# kube high slim rgb led light indoor modulo • module

pag. 104

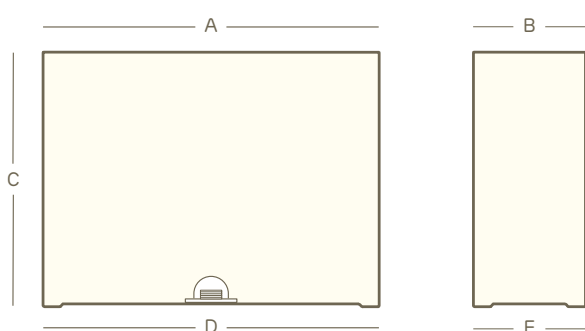

Art. 2805  
cm. 80

A	cm. 80
B	cm. 25
C	cm. 70
D	cm. 80
E	cm. 25

# kube high slim light outdoor cassetta alta • high plant box

pag. 103

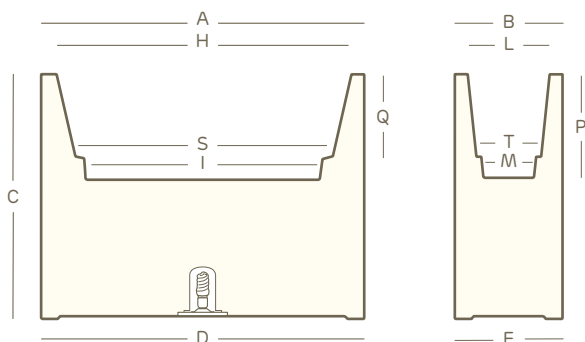

Art. 2793  
cm. 80

A	cm. 80	M	cm. 14
B	cm. 25	P	cm. 25
C	cm. 70	Q	cm. 20
D	cm. 80	S	cm. 68
E	cm. 25	T	cm. 18
H	cm. 75		
I	cm. 49		
L	cm. 20		

# kube high slim rgb led light outdoor cassetta alta • high plant box

pag. 103

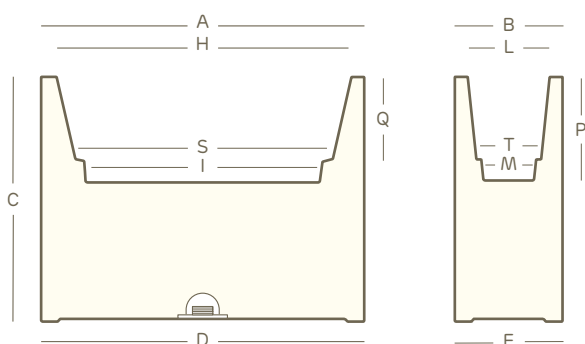

Art. 2795  
cm. 80

A	cm. 80	M	cm. 14
B	cm. 25	P	cm. 25
C	cm. 70	Q	cm. 20
D	cm. 80	S	cm. 68
E	cm. 25	T	cm. 18
H	cm. 75		
I	cm. 49		
L	cm. 20		

# kube high slim light outdoor modulo • module

pag. 104

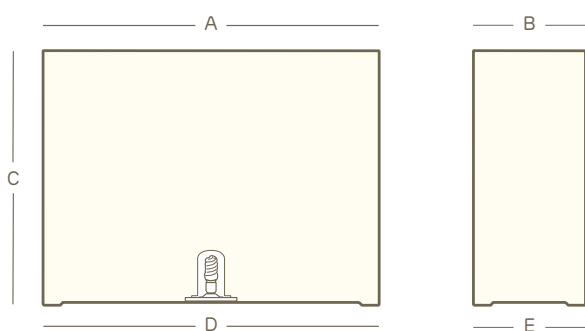

Art. 2804  
cm. 80

A	cm. 80
B	cm. 25
C	cm. 70
D	cm. 80
E	cm. 25

# kube high slim rgb led light outdoor modulo • module

pag. 104

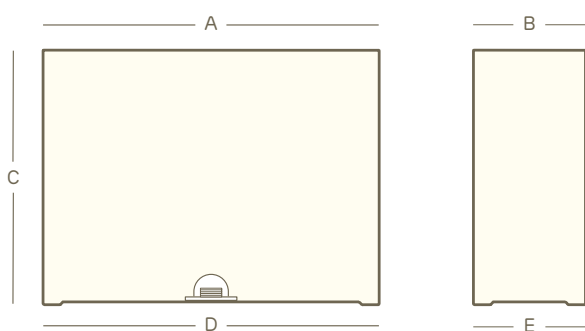

Art. 2805  
cm. 80

A	cm. 80
B	cm. 25
C	cm. 70
D	cm. 80
E	cm. 25

## kube high slim light indoor vaso alto • high pot

pag. 102

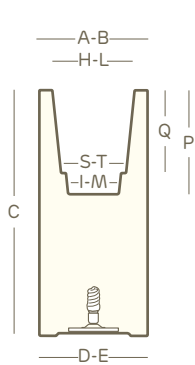

Art. 2796  
cm. 25

A-B cm. 25  
C cm. 70  
D-E cm. 25  
H-L cm. 20  
I-M cm. 15  
P cm. 26,5  
Q cm. 20  
S-T cm. 18

## kube high slim rgb led light indoor vaso alto • high pot

pag. 102

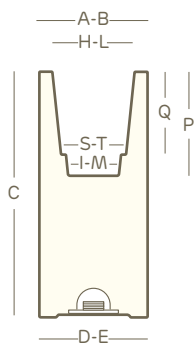

Art. 2798  
cm. 25

A-B cm. 25  
C cm. 70  
D-E cm. 25  
H-L cm. 20  
I-M cm. 15  
P cm. 26,5  
Q cm. 20  
S-T cm. 18

## kube high slim light indoor modulo • module

pag. 104



Art. 2800  
cm. 25

A-B cm. 25  
C cm. 70  
D-E cm. 25

## kube high slim rgb led light indoor modulo • module

pag. 104

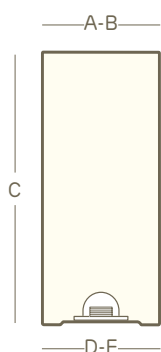

Art. 2802  
cm. 25

A-B cm. 25  
C cm. 70  
D-E cm. 25

## kube high slim light outdoor vaso alto • high pot

pag. 102

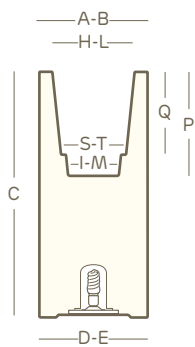

Art. 2797  
cm. 25

A-B cm. 25  
C cm. 70  
D-E cm. 25  
H-L cm. 20  
I-M cm. 15  
P cm. 26,5  
Q cm. 20  
S-T cm. 18

## kube high slim rgb led light outdoor vaso alto • high pot

pag. 102

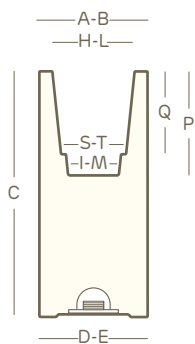

Art. 2799  
cm. 25

A-B cm. 25  
C cm. 70  
D-E cm. 25  
H-L cm. 20  
I-M cm. 15  
P cm. 26,5  
Q cm. 20  
S-T cm. 18

## kube high slim light outdoor modulo • module

pag. 104



Art. 2801  
cm. 25

A-B cm. 25  
C cm. 70  
D-E cm. 25

## kube high slim rgb led light outdoor modulo • module

pag. 104

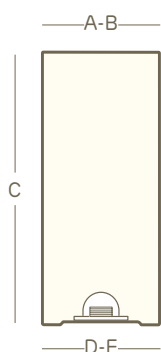

Art. 2802  
cm. 25

A-B cm. 25  
C cm. 70  
D-E cm. 25

# kube tower light indoor cassetta alta • high plant box

pag. 107

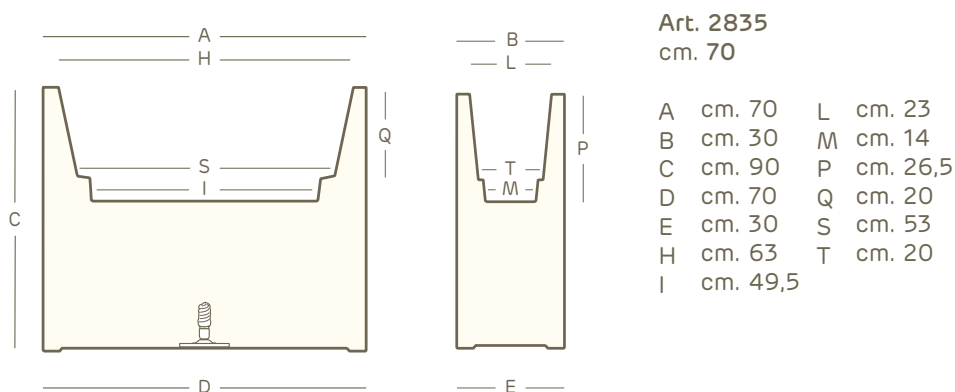

# kube tower rgb led light indoor cassetta alta • high plant box

pag. 107

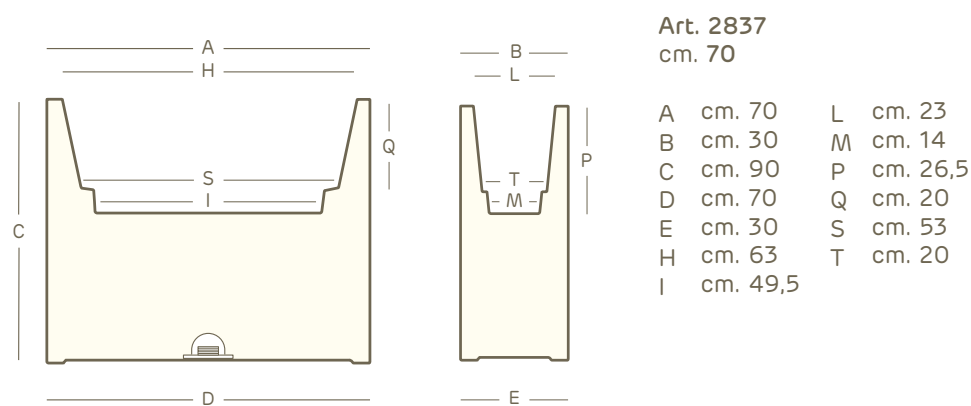

# kube tower light indoor vaso alto • high pot

pag. 106

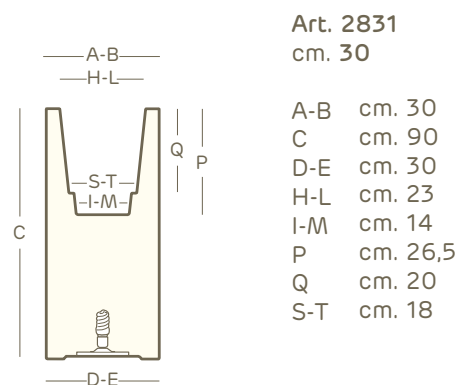

# kube tower rgb led light indoor vaso alto • high pot

pag. 106

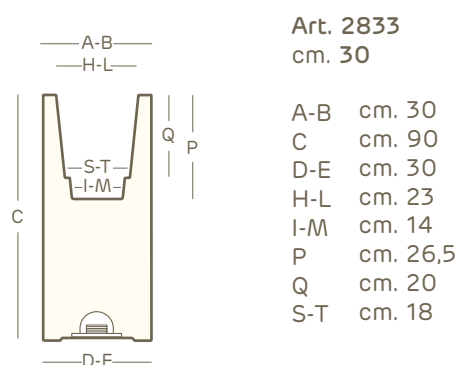



# kube tower light outdoor cassetta alta • high plant box

pag. 107

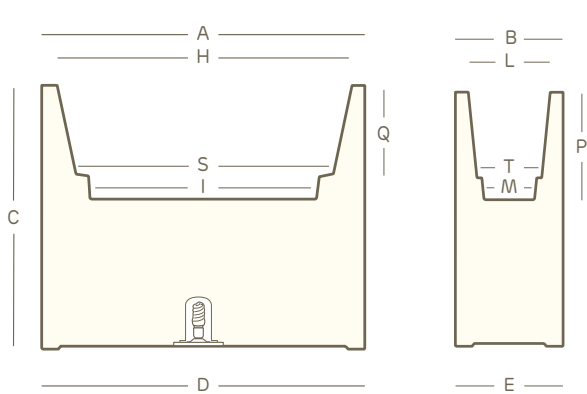

Art. 2836  
cm. 70

A	cm. 70	L	cm. 23
B	cm. 30	M	cm. 14
C	cm. 90	P	cm. 26,5
D	cm. 70	Q	cm. 20
E	cm. 30	S	cm. 53
H	cm. 63	T	cm. 20
I	cm. 49,5		

# kube tower rgb led light outdoor cassetta alta • high plant box

pag. 107

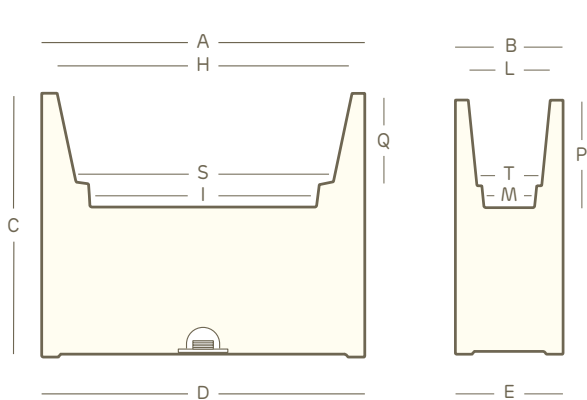

Art. 2838  
cm. 70

A	cm. 70	L	cm. 23
B	cm. 30	M	cm. 14
C	cm. 90	P	cm. 26,5
D	cm. 70	Q	cm. 20
E	cm. 30	S	cm. 53
H	cm. 63	T	cm. 20
I	cm. 49,5		

# kube tower light outdoor vaso alto • high pot

pag. 106

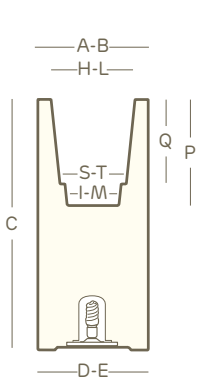

Art. 2832  
cm. 30

A-B	cm. 30
C	cm. 90
D-E	cm. 30
H-L	cm. 23
I-M	cm. 14
P	cm. 26,5
Q	cm. 20
S-T	cm. 18

# kube tower rgb led light outdoor vaso alto • high pot

pag. 106

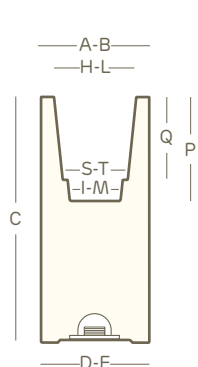

Art. 2834  
cm. 30

A-B	cm. 30
C	cm. 90
D-E	cm. 30
H-L	cm. 23
I-M	cm. 14
P	cm. 26,5
Q	cm. 20
S-T	cm. 18

## quadrum light indoor

pag. 91

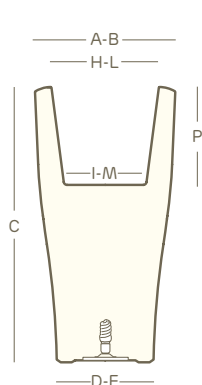

Art. 2711  
cm. 51

A-B cm. 51  
C cm. 100  
D-E cm. 35  
H-L cm. 39  
I-M cm. 30  
P cm. 35

## quadrum rgb led light indoor

pag. 91

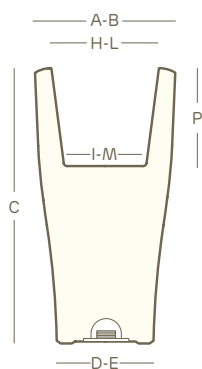

Art. 2713  
cm. 51

A-B cm. 51  
C cm. 100  
D-E cm. 35  
H-L cm. 39  
I-M cm. 30  
P cm. 35

## sfera light indoor

pag. 96

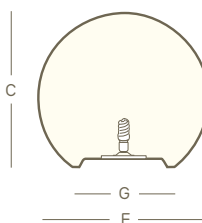

Art. 2639    Art. 2715    Art. 2718  
ø cm. 45    ø cm. 55    ø cm. 65

C cm. 40    C cm. 50    C cm. 60  
F cm. 45    F cm. 55    F cm. 65  
G cm. 28    G cm. 31    G cm. 34

## sfera rgb led light indoor

pag. 96

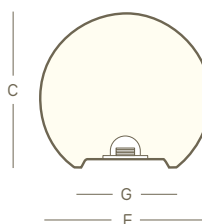

Art. 2749    Art. 2717    Art. 2720  
ø cm. 45    ø cm. 55    ø cm. 65

C cm. 40    C cm. 50    C cm. 60  
F cm. 45    F cm. 55    F cm. 65  
G cm. 28    G cm. 31    G cm. 34

## quadrum light outdoor

pag. 91

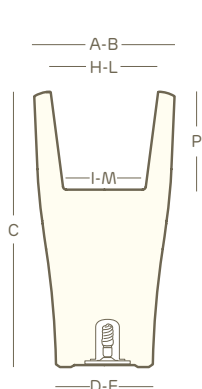

Art. 2712  
cm. 51

A-B cm. 51  
C cm. 100  
D-E cm. 35  
H-L cm. 39  
I-M cm. 30  
P cm. 35

## quadrum rgb led light outdoor

pag. 91

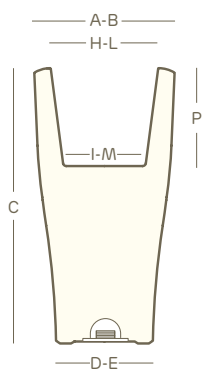

Art. 2714  
cm. 51

A-B cm. 51  
C cm. 100  
D-E cm. 35  
H-L cm. 39  
I-M cm. 30  
P cm. 35

## sfera light outdoor

pag. 96

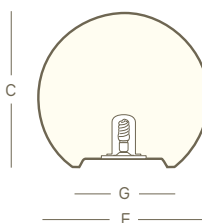

Art. 2651	Art. 2716	Art. 2719
ø cm. 45	ø cm. 55	ø cm. 65

C cm. 40	C cm. 50	C cm. 60
F cm. 45	F cm. 55	F cm. 65
G cm. 38	G cm. 31	G cm. 34

## sfera rgb led light outdoor

pag. 96

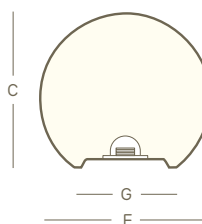

Art. 2749	Art. 2717	Art. 2720
ø cm. 45	ø cm. 55	ø cm. 65

C cm. 40	C cm. 50	C cm. 60
F cm. 45	F cm. 55	F cm. 65
G cm. 38	G cm. 31	G cm. 34

## sfera con piedistallo light indoor

pag. 98

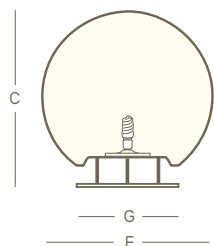

Art. 2759  
Ø cm. 65

C cm. 70  
G cm. 34  
F cm. 65

## sfera con piedistallo rgb led light indoor

pag. 98

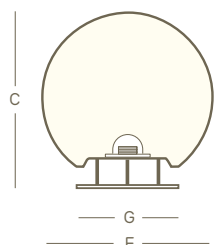

Art. 2761  
Ø cm. 65

C cm. 70  
G cm. 34  
F cm. 65

## sfera con piedistallo light outdoor

pag. 98

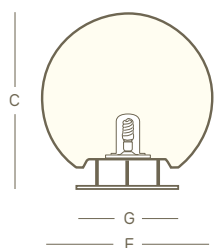

Art. 2760  
Ø cm. 65

C cm. 70  
G cm. 34  
F cm. 65

## sfera con piedistallo rgb led light outdoor

pag. 98

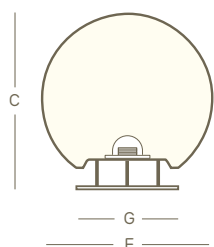

Art. 2761  
Ø cm. 65

C cm. 70  
G cm. 34  
F cm. 65

## ikon lighting colors indoor

pag. 108

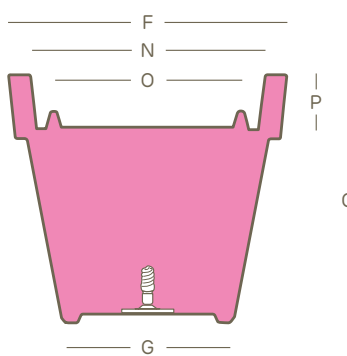

Art. 2721	Art. 2725	Art. 2729	Art. 2899
ø cm. 40	ø cm. 50	ø cm. 60	ø cm. 70
C cm. 36	C cm. 44	C cm. 53	C cm. 62
F cm. 40	F cm. 50	F cm. 60	F cm. 70
G cm. 23	G cm. 29	G cm. 35	G cm. 42
N cm. 34	N cm. 43	N cm. 52	N cm. 60
O cm. 25	O cm. 30	O cm. 37	O cm. 44
P cm. 6,7	P cm. 8,4	P cm. 10	P cm. 12

## ikon lighting colors indoor

pag. 108

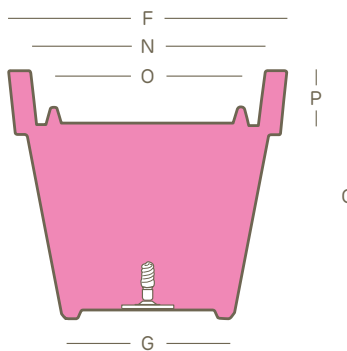

Art. 2641	Art. 2653	Art. 2657
ø cm. 80	ø cm. 100	ø cm. 120
C cm. 71	C cm. 89	C cm. 107
F cm. 80	F cm. 100	F cm. 120
G cm. 47	G cm. 59	G cm. 72
N cm. 69	N cm. 86	N cm. 103
O cm. 50	O cm. 62	O cm. 75
P cm. 13	P cm. 18	P cm. 22

## ilie gloss lighting colors indoor

pag. 110

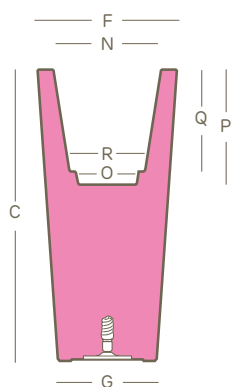

Art. 2677	Art. 2681	Art. 2685
ø cm. 37	ø cm. 47	ø cm. 57
C cm. 75	C cm. 98	C cm. 126
F cm. 37	F cm. 47	F cm. 57
G cm. 26	G cm. 33	G cm. 40
N cm. 28	N cm. 36	N cm. 44
O cm. 15	O cm. 20	O cm. 28
P cm. 33	P cm. 41	P cm. 50
Q cm. 27	Q cm. 35	Q cm. 44
R cm. 20	R cm. 25	R cm. -32

## kiam gloss lighting colors indoor

pag. 112

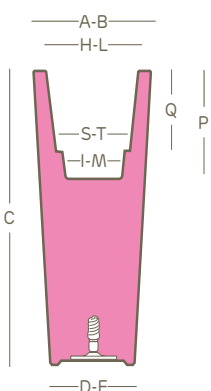

Art. 2689
cm. 40
A-B cm. 40
C cm. 90
D-E cm. 28
H-L cm. 30
I-M cm. 21
P cm. 33
Q cm. 27
S-T cm. 24

# ikon lighting colors outdoor

pag. 108

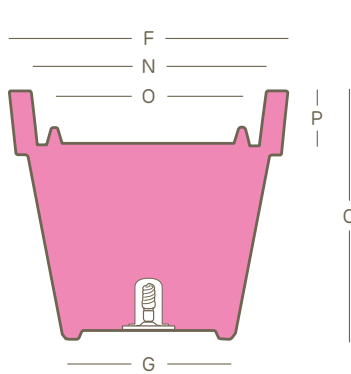

Art. 2722	Art. 2726	Art. 2730	Art. 2900
ø cm. 40	ø cm. 50	ø cm. 60	ø cm. 70
C cm. 36	C cm. 44	C cm. 53	C cm. 62
F cm. 40	F cm. 50	F cm. 60	F cm. 70
G cm. 23	G cm. 29	G cm. 35	G cm. 42
N cm. 34	N cm. 43	N cm. 52	N cm. 60
O cm. 25	O cm. 30	O cm. 37	O cm. 44
P cm. 6,7	P cm. 8,4	P cm. 10	P cm. 12

# ikon lighting colors outdoor

pag. 108

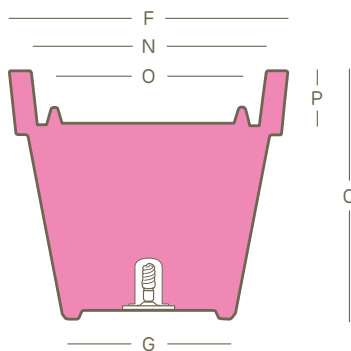

Art. 2642	Art. 2654	Art. 2658
ø cm. 80	ø cm. 100	ø cm. 120
C cm. 71	C cm. 89	C cm. 107
F cm. 80	F cm. 100	F cm. 120
G cm. 47	G cm. 59	G cm. 72
N cm. 69	N cm. 86	N cm. 103
O cm. 50	O cm. 62	O cm. 75
P cm. 13	P cm. 18	P cm. 22

# ilie gloss lighting colors outdoor

pag. 110

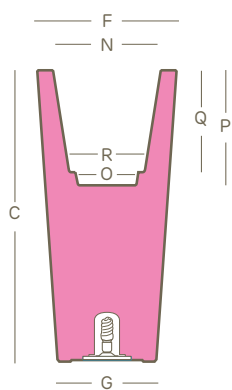

Art. 2678	Art. 2682	Art. 2686
ø cm. 37	ø cm. 47	ø cm. 57
C cm. 75	C cm. 98	C cm. 126
F cm. 37	F cm. 47	F cm. 57
G cm. 26	G cm. 33	G cm. 40
N cm. 28	N cm. 36	N cm. 44
O cm. 15	O cm. 20	O cm. 28
P cm. 33	P cm. 41	P cm. 50
Q cm. 27	Q cm. 35	Q cm. 44
R cm. 20	R cm. 25	R cm. 32

# kiam gloss lighting colors outdoor

pag. 112

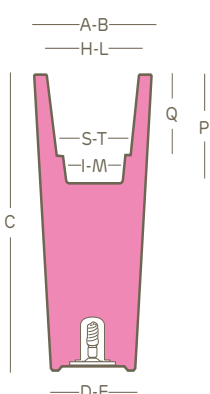

Art. 2690
cm. 40
A-B cm. 40
C cm. 90
D-E cm. 28
H-L cm. 30
I-M cm. 21
P cm. 33
Q cm. 27
S-T cm. 24

# Legenda / Legend



Lampada fluorescente MAX 1 x 60 W  
Fluorescent lamp MAX 1 x 60 W



Classe di isolamento: Classe II.  
Con doppio isolamento e/o rinforzo in ogni parte e senza dispositivi per la messa a terra.  
Insulation class: Class II.  
With double insulation and/or reinforcement in each part and without ground devices.



Attesta la conformità del prodotto alle disposizioni delle direttive comunitarie.  
It certifies the conformity of the product to the European community instructions.

IP 20

Prodotto con nessuna protezione nei confronti della penetrazione dell'acqua.  
L'utente non ha comunque modo di entrare fisicamente in contatto con parti in tensione.  
Product not protected against penetration of water.  
Nevertheless, the user does not come into physical contact with the parts under tension.

IP 67

Prodotto resistente all'immersione temporanea.  
L'icona, dove presente, fa riferimento al corpo lampada.  
The product is temporary immersion proof.  
When showed, the icon refers to the lamp body.

IP 68

Protezione totale alla penetrazione di corpi solidi e polveri. Protezione contro l'immersione in acqua permanente a 1 metro di profondità.  
Total protection against penetration of solid bodies and dust. Protected from continuous immersion in water 1 meter deep.



Ai sensi della Direttiva 2012/19/UE, il prodotto, alla fine della sua vita utile, non deve essere smaltito come rifiuto urbano.  
According to the Directive 2012/19/UE, once the device life time is ended, it must not be disposed as urban waste.

Tutte le apparecchiature elettriche sono conformi alle direttive 2011/65/UE sulle Restrizioni d'uso di alcune sostanze pericolose (RoHS), recepite in Italia con il D.lgs 04/03/2014 n.27.

All electric equipments meet the Directives 2011/65/UE about the Reduction of the use of certain Hazardous Substances (RoHS), which came into force in Italy with D. lgs 04/03/2014 n.27.

## Avvertenze - Warning:

- Collegare la spina dell'apparecchio in una presa collocata in un luogo protetto dalla pioggia e dagli spruzzi d'acqua.
- Se il cavo flessibile esterno di questo apparecchio viene danneggiato, deve essere sostituito esclusivamente dal costruttore, dal suo servizio di assistenza, o da personale qualificato equivalente, al fine di evitare pericoli.
- Nelle versioni sprovviste di interruttore sul cavo di alimentazione, collegare la spina dell'apparecchio sotto una presa comandata da interruttore.
- Connect the plug of the appliance to a power outlet that is located in a sheltered position, protected from rain and water splashes.
- If the external flexible cable of this appliance is damaged it must be replaced by either the manufacturer, the manufacturer's customer assistance service or by equivalent qualified personnel, in order to prevent possible hazards.
- For models that are not equipped with an inline on/off switch, connect the plug of the appliance to a switch controlled outlet.



# khilia mini lights

---

dati tecnici

technical data

## mini ikon light

pag. 118

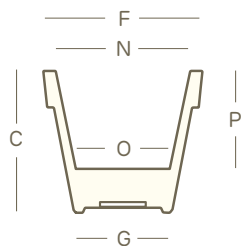

Art. 2782  
 ø cm. 20

C cm. 17,5  
 F cm. 20  
 G cm. 11,5  
 N cm. 16  
 O cm. 11  
 P cm. 12

## mini kube light

pag. 120

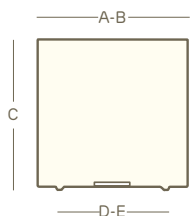

Art. 2784  
 cm. 20

A-B cm. 20  
 C cm. 20  
 D-E cm. 15

## mini kube light cassetta - plant box

pag. 122

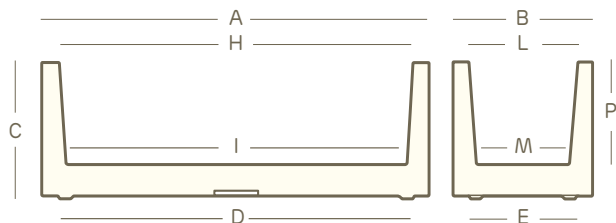

Art. 2791  
 cm. 60

A cm. 60  
 B cm. 20  
 C cm. 20  
 D cm. 55  
 E cm. 14,5  
 H cm. 55  
 I cm. 52  
 L cm. 15  
 M cm. 13  
 P cm. 15,5

## mini kube light vaso - pot

pag. 119

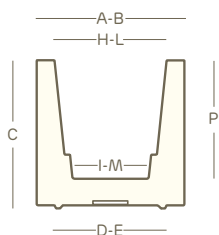

Art. 2783  
 cm. 20

A-B cm. 20  
 C cm. 20  
 D-E cm. 15  
 H-L cm. 15  
 I-M cm. 12  
 P cm. 14,5

# mini sfera light

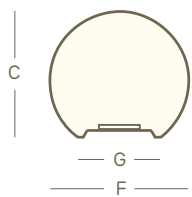

Art. 2636  
cm. 20

C cm. 18  
F cm. 20  
G cm. 11,5

## khilia kit luce per interni

pag. 124

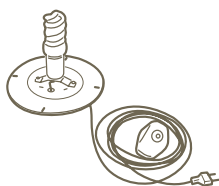

khilia kit luce in PC per **interni**  
**indoor** PC khilia light kit

Il kit luce è compatibile con lampadine di classi energetiche E → A++, ed è venduto con una lampada di classe energetica A.

The light kit is compatible with bulbs of the energy class E → A++, and is sold with a bulb of the energy class A.

art. A4279

dettagli • details

**piastra in policarbonato** • polycarbonate plate  
**cavo trasparente** • transparent cable  
**pulsantiera a pedale** • foot switch  
**spina europea bipolare** • european bipolar plug  
**lunghezza cavo** • wire length: **cm. 370**

luce • light  
1 x 20 W



## khilia kit luce per esterni

pag. 125

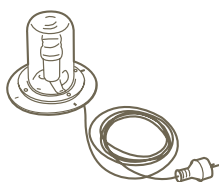

khilia kit luce in PC per **esterni**  
**outdoor** PC khilia light kit

Il kit luce è compatibile con lampadine di classi energetiche E → A++, ed è venduto con una lampada di classe energetica A.

The light kit is compatible with bulbs of the energy class E → A++, and is sold with a bulb of the energy class A.

art. A4280

dettagli • details

**piastra in policarbonato** • polycarbonate plate  
**guscio in policarbonato** • polycarbonate shell  
**guarnizione a tenuta** • gasket seal  
**cavo nero** - black cable  
**spina schuko antispruzzo** • anti-splash  
**lunghezza cavo** • wire length: **cm. 290**

luce • light • licht • luz • ampoule  
1 x 20 W



## kit led rgb per interni/esterni

pag. 126

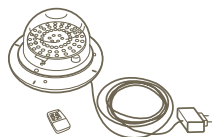

kit led rgb per **interni/esterni**  
rgb led light kit **indoor/outdoor**

Il kit luce è munito di lampade a LED integrate con classe energetica A→A++.

The light kit is equipped with integrated LED bulbs of the energy class A → A++.

art. A4307

dettagli • details

**telecomando** • remote control  
**cavo nero** • black cable  
**spina europea bipolare** • european bipolar plug  
**trasformatore in 12V a parete** • 12V wall transformer  
**predisposizione per base di stabilizzazione**  
arrangement for stability base  
**lunghezza cavo** • wire length: **cm. 500**

luce • light  
**modulo 60 led rgb 15W**  
15W 60 led rgb module



## kit led rgb a batteria con spina per interni/esterni

pag. 128

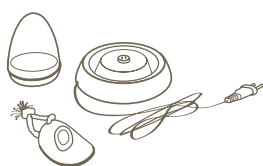

kit led rgb a batteria con spina per  
**interni/esterni**  
rgb led light kit with battery with plug  
**indoor/outdoor**

art. A4364

### dettagli • details

**kit led rgb powered by smart&green**

**autonomia 6 ore circa alla massima intensità**

autonomy 6 hours on average at maximum power

**telecomando • remote control**

**base di ricarica con spina europea bipolare**

european bipolar plug charger

**diffusore in polietilene resistente ai raggi u.v. e agli urti**

polyethylene plastic diffuser, resistant to u.v. and shocks

**batteria litio • polimeri 1750 mAh • battery litio-polymer  
1750 mAh**

### luce • light

**52 led bianchi e colorati ad alta intensità che  
producono 160.000 colori**

52 high intensity white and color led offering  
160.000 colors



IP 68



## kit mini led light per interni

pag. 130

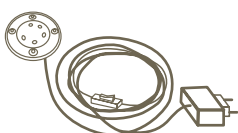

kit mini led light per **interni**  
mini led light kit **indoor**

art. A4303

### dettagli • details

**cavo trasparente • transparent cable**

**spina europea bipolare • european bipolar plug**

**trasformatore in 12V a parete • 12V wall transformer**

**pulsantiera • swich**

### luce • light

**modulo 6 led bianchi 1,5 W**

1,5 W white 6 led module

**Il kit luce è munito di lampade a LED  
integrate con classe energetica A → A++.**

The light kit is equipped with integrated LED  
bulbs of the energy class A → A++.



IP 20





# khilia riserva d'acqua

---

dati tecnici

technical data

rotonde • round

## kit riserva d'acqua ø 20

kit riserva d'acqua ø 20  
water reserve kit ø 20

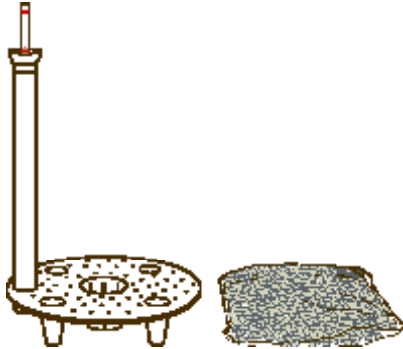

adatto a • fitting to:  
aso ø cm. 37  
aso gloss ø cm. 37  
aso laccato ø cm. 37  
vaso gloss ø cm. 40

art. A4256

dettagli • details

griglia • separator: ø cm. 20

tubo con indicatore livello acqua • supply shaft with water level gauge: h. cm. 40

argilla espansa • expanded clay: lt. 1

capacità riserva acqua • water reserve capacity: lt. 1,3

07

nero  
black  
schwarz  
negro  
noir

## kit riserva d'acqua ø 25

kit riserva d'acqua ø 25  
water reserve kit ø 25

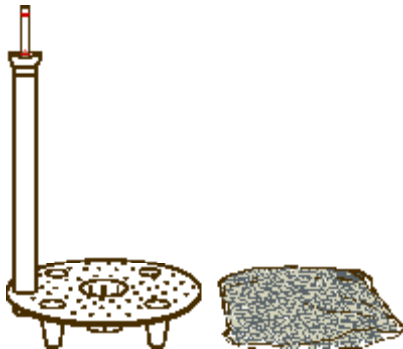

adatto a • fitting to:  
aso ø cm. 47  
aso gloss ø cm. 47  
aso laccato ø cm. 47  
vaso gloss ø cm. 50

art. A4239

dettagli • details

griglia • separator: ø cm. 25

tubo con indicatore livello acqua • supply shaft with water level gauge: h. cm. 47,5

argilla espansa • expanded clay: lt. 2

capacità riserva acqua • water reserve capacity: lt. 2,5

07

nero  
black  
schwarz  
negro  
noir

## kit riserva d'acqua ø 32

kit riserva d'acqua ø 32  
water reserve kit ø 32

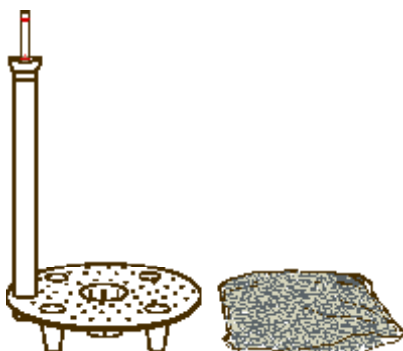

adatto a • fitting to:  
aso ø cm. 57  
aso gloss ø cm. 57  
aso laccato ø cm. 57  
vaso gloss ø cm. 60

art. A4240

dettagli • details

griglia • separator: ø cm. 32

tubo con indicatore livello acqua • supply shaft with water level gauge: h. cm. 57,5

argilla espansa • expanded clay: lt. 3

capacità riserva acqua • water reserve capacity: lt. 4

07

nero  
black  
schwarz  
negro  
noir



quadrate • square

## kit riserva d'acqua cm. 17

kit riserva d'acqua cm. 17  
water reserve kit cm. 17

art. A4255

abbinato a • fitting to:  
kiam vaso gloss cm. 30  
kuba vaso cm. 30  
kuba vaso cm. 30 con ruote  
kuba vaso gloss cm. 30  
kuba vaso gloss cm. 30 con ruote  
kuba high vaso cm. 30  
kuba high vaso cm. 30 con ruote  
kuba high slim vaso cm. 25  
kuba tower vaso cm. 30

dettagli • details

griglia • separator: cm. 17 x 17

tubo con indicatore livello acqua • supply shaft with water level gauge: h. cm. 33,5

argilla espansa • expanded clay: lt. 1

capacità riserva acqua • water reserve capacity: lt. 1,2

nero  
black  
schwarz  
negro  
noir

07

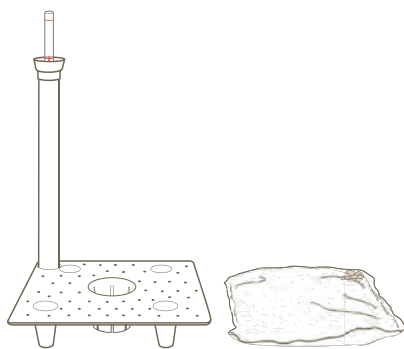

## kit riserva d'acqua cm. 17

kit riserva d'acqua cm. 17  
water reserve kit cm. 17

art. A4373

abbinato a • fitting to:  
kiam vaso gloss cm. 35

dettagli • details

griglia • separator: cm. 17 x 17

tubo con indicatore livello acqua • supply shaft with water level gauge: h. cm. 38

argilla espansa • expanded clay: lt. 1

capacità riserva acqua • water reserve capacity: lt. 1,2

nero  
black  
schwarz  
negro  
noir

07

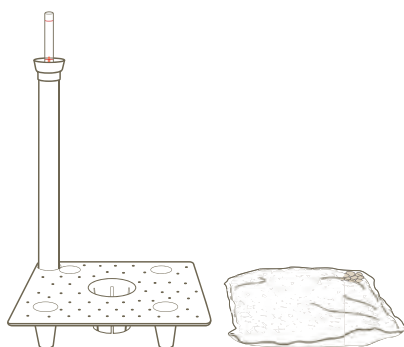

## kit riserva d'acqua cm. 24

kit riserva d'acqua cm. 24  
water reserve kit cm. 24

art. A4241

abbinato a • fitting to:  
kiam vaso gloss cm. 40  
kuba vaso cm. 40  
kuba vaso cm. 40 con ruote  
kuba vaso gloss cm. 40  
kuba vaso gloss cm. 40 con ruote  
kuba high vaso cm. 40  
kuba high vaso cm. 40 con ruote

dettagli • details

griglia • separator: cm. 24 x 24

tubo con indicatore livello acqua • supply shaft with water level gauge: h. cm. 40

argilla espansa • expanded clay: lt. 2

capacità riserva acqua • water reserve capacity: lt. 3

nero  
black  
schwarz  
negro  
noir

07

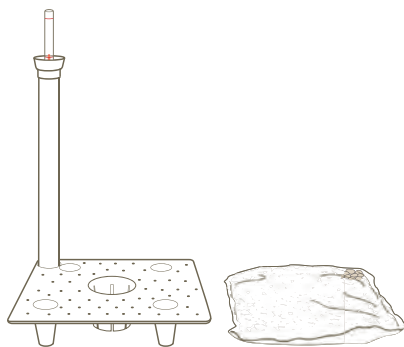

# kit riserva d'acqua cm. 30

kit riserva d'acqua cm. 30  
water reserve kit cm. 30

art. A4242

abbinato a • fitting to:  
kube vaso cm. 50  
kube vaso cm. 50 con ruote  
kube vaso gloss cm. 50  
kube vaso gloss cm. 50 con ruote

dettagli • details  
griglia • separator: cm. 30x30  
tubo con indicatore livello acqua • supply shaft  
with water level gauge: h. cm. 48,5  
argilla espansa • expanded clay: lt. 3  
capacità riserva acqua • water reserve capacity: lt. 5

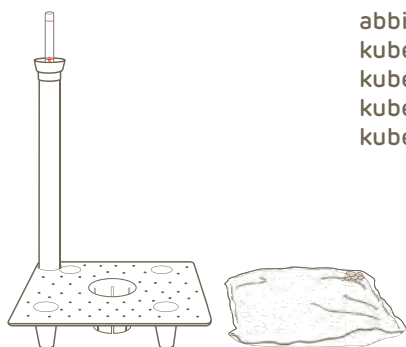

07

nero  
black  
schwarz  
negro  
noir

# cassette • plant boxes

## kit riserva d'acqua cm. 17 x 51

kit riserva d'acqua cm. 17x51  
water reserve kit cm. 17x51

art. A4327

abbinato a • fitting to:  
kube cassetta cm. 80  
kube cassetta cm. 80 con ruote  
kube high cassetta cm. 80  
kube high cassetta cm. 80 con ruote  
kube high slim cassetta cm. 80  
kube tower cassetta cm. 70

dettagli • details

griglia • separator: 3 x cm. 17 x 17  
tubo con indicatore livello acqua • supply shaft with water level gauge: h. cm. 33,5  
argilla espansa • expanded clay: 3 x lt. 1  
capacità riserva acqua • water reserve capacity: lt. 3,6

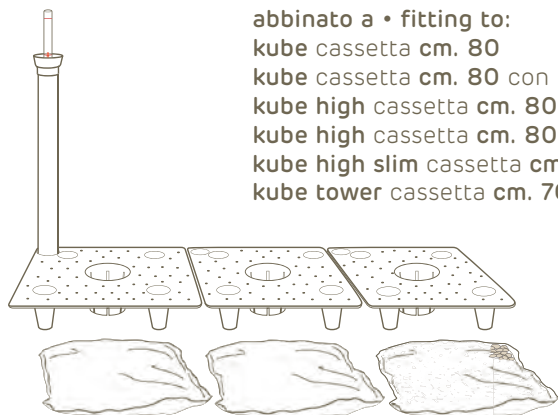

07  
nero  
black  
schwarz  
negro  
noir

## kit riserva d'acqua cm. 24 x 72

kit riserva d'acqua cm. 24x72  
water reserve kit cm. 24x72

art. A4278

abbinato a • fitting to:  
kube cassetta cm. 100  
kube cassetta cm. 100 con ruote  
kube high cassetta cm. 100  
kube high cassetta cm. 100 con ruote

dettagli • details

griglia • separator: 3 x cm. 24 x 24  
tubo con indicatore livello acqua • supply shaft with water level gauge: h. cm. 40  
argilla espansa • expanded clay: 3 x lt. 2  
capacità riserva acqua • water reserve capacity: lt. 9

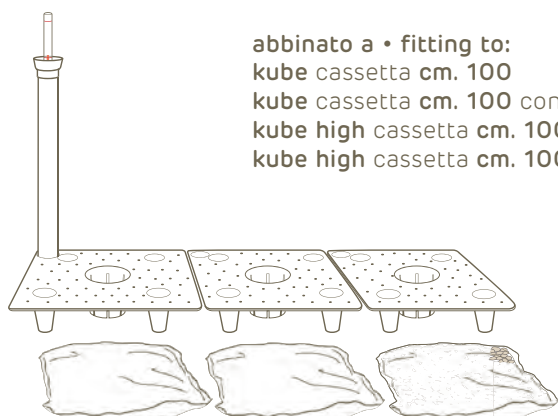

07  
nero  
black  
schwarz  
negro  
noir

# colors

## collection

- C2** bianco  
white  
weiss  
blanco  
blanc
- G9** tortora  
taupe  
taupe  
tortola  
tourterelle
- 87** nero perla  
pearl black  
pearl schwarz  
negro perla  
noir perle
- 07** nero  
black  
schwarz  
negro  
noir
- 86** verde acido  
acid green  
apfel grün  
verde acido  
vert anis
- A2** verde A2  
green A2  
grün A2  
verde A2  
vert A2
- 43** verde smeraldo  
emerald green  
petrol  
verde esmeralda  
vert emeraude
- A9** rosso  
red  
rot  
rojo  
rouge
- D7** rosso oriente  
orient red  
orientrot  
rojo oriente  
rouge orient
- E5** ruggine  
rust  
rost  
oxido  
rouille
- C1** arancio  
orange  
orange  
naranja  
orange

## gloss

- C2** bianco  
white  
weiss  
blanco  
blanc
- 86** verde acido  
acid green  
apfel grün  
verde acido  
vert anis
- 43** verde smeraldo  
emerald green  
petrol  
verde esmeralda  
vert emeraude
- 88** viola  
violet  
violett  
violeta  
violet
- G8** porpora  
purple  
purpur  
purpura  
pourpre
- A9** rosso  
red  
rot  
rojo  
rouge
- D7** rosso oriente  
orient red  
orientrot  
rojo oriente  
rouge orient
- E5** ruggine  
rust  
rost  
oxido  
rouille

## laccati

- 03** bianco  
white  
weiss  
blanco  
blanc
- 07** nero  
black  
schwarz  
negro  
noir
- D7** rosso oriente  
orient red  
orientrot  
rojo oriente  
rouge orient

## light

- 98** neutro  
neutral  
neutral  
transparente  
neutre
- 86** verde acido  
acid green  
apfel grün  
verde acido  
vert anis
- 74** fucsia  
fuchsia  
fuchsia  
fuchsia  
fuchsia



---

# pastel colors

M9

sabbia  
sandy  
sand  
arena  
sable

N1

giada  
jade  
jade  
jade  
jade

L4

rosmarino  
rosemary  
rosmarin  
romero  
romarin

N2

cenere  
ashen  
asche  
ceniza  
cendre

NO

cipria  
powder  
puder  
polvo  
poudre

69

avorio  
ivory  
elfenbein  
marfil  
ivoire



---

# special colors



nero - verde  
black - green  
schwarz - grün  
negro - verde  
noir - vert



nero - arancio  
black - orange  
schwarz - orange  
negro - naranja  
noir - orange





ATTENZIONE: La stampa su carta non sempre riproduce fedelmente i colori dei prodotti.

Le immagini e i dati riportati in questo catalogo sono indicativi. **euro3plast spa** si riserva il diritto di apportare eventuali variazioni o migliorie agli articoli illustrati, anche senza preavviso. I nostri uffici commerciali rimangono a vostra completa disposizione per qualsiasi ulteriore delucidazione.

Tutto il materiale contenuto in questo catalogo, compresi i testi, le fotografie, i disegni, è proprietà di **euro3plast spa** e pertanto è protetto dalle leggi che tutelano la proprietà intellettuale. Per tale motivo non può essere utilizzato senza esplicita autorizzazione scritta da **euro3plast spa**.

ATTENTION: The print on the paper doesn't grant the accurate reproduction of the colors.

The images and the indicated data in our catalogue are approximate. **euro3plast spa** reserves the right to effect any changes or improvements, to the illustrated articles, also without notice. For further information, our Customer Service are at your disposal.

All the material in this catalogue (including texts, photos and drawing), belong to **euro3plast spa**. Therefore it is protected by laws defending intellectual property. For this reason it cannot be used by anybody without the prior and written authorization of **euro3plast spa**.

graphic design & art director  
Euro3plast spa

photo  
Lorenzo Ceretta  
Riccardo Urnato

print  
Ciesse Printer s.r.l.



MISTO  
Carta da fonti gestite  
in maniera responsabile  
FSC® C012008

