



KHILIA collection 2018

khilia collection 2018

collection	p. 2
special colors	p. 42
mini	p. 50
gloss	p. 64
laccati • lacquered	p. 70
lights	p. 76
mini lights	p. 98
kit luce • light kit	p. 105
utilizzo • suggestions	p. 114
avvertenze • warnings	p. 128
merchandising tools	p. 130
dati tecnici • technical data	p. 139
colors	p. 186

khilia collection

Pratici, eleganti e rispettosi dell'ambiente, arredano sia gli ambienti esterni che quelli interni creando angoli dall'effetto suggestivo. Sono tutti realizzati con resine termoplastiche (PE) resistenti agli urti, agli agenti atmosferici (-65°, +85°), ai raggi U.V. e sono interamente riciclabili.

These practical and elegant products are environmentally friendly that look good both indoors and out, helping to create attractive and picturesque features. All are made from polyethylene (PE) resin and so offer maximum resistance to shocks, atmospheric agents (-65°to +85°), UV rays and are completely recyclable.

Praktisch, elegant und umweltbewusst, richten sie sowohl Außenbereiche als auch Innenräume ein und schaffen dabei Ecken mit faszinierenden Effekten. Sie bestehen allesamt aus schlagfesten, wetterfesten (-65°, +85°) und gegenüber von UV – Strahlen beständigen Thermoplast - Harzen (PE) und sind vollständig recyclingfähig.

Prácticos, elegantes y respetuosos del medioambiente, decoran los ambientes exteriores e interiores creando rincones con efectos sugestivos. Todos realizados con resinas termoplásticas (PE) y resistentes a los golpes, a los agentes atmosféricos (-65°, +85°) y a los rayos UV. Además, todos los productos son íntegramente reciclables.

Pratiques, élégants et respectueux de l'environnement. Conçus pour l'ameublement des grands espaces, tant à l'extérieur qu'à l'intérieur, où ils créent des angles aux effets évocateurs. Tous les articles sont réalisés en résines thermoplastiques (PE) résistant aux chocs, aux agents atmosphériques (-65°, +85°) et aux rayons U.V. et ils sont entièrement recyclables.



100%
Recyclable



Lightweight



Antishock



U.V.
Resistant



-65°C
+85°C
Resistant

index

akan cassetta	p. 22
akan vaso	p. 23
etria	p. 16
ikon	p. 6
ilie	p. 10
kiam	p. 12
kube cassetta	p. 26
kube vaso	p. 24
kube panca	p. 40
kube sgabello	p. 41
kube high cassetta alta	p. 31
kube high vaso alto	p. 30
kube high slim cassetta alta	p. 35
kube high slim vaso alto	p. 34
kube high slim modulo	p. 36
kube tower cassetta	p. 39
kube tower vaso	p. 38
niscal	p. 20
opus	p. 21
quadrum	p. 15
tulum	p. 14





ikon



ikon

vaso • pot
pflanzkübel • maceta • pot

art. 2603	Ø 40	(cm. 40 x 36 h.)	lt. 23	art. 2896	Ø 70	(cm. 70 x 62 h.)	lt. 130	*●●●	art. 2543	Ø 120	(cm. 120 x 107 h.)	lt. 680	*●●●●	
art. 2604	Ø 50	(cm. 50 x 44 h.)	lt. 47	*●●●	art. 2541	Ø 80	(cm. 80 x 71 h.)	lt. 202	*●●●●	art. 2786	Ø 140	(cm. 140 x 125 h.)	lt. 1066	*●●●●
art. 2605	Ø 60	(cm. 60 x 53 h.)	lt. 82	*●●●	art. 2542	Ø 100	(cm. 100 x 89 h.)	lt. 398	*●●●●	art. 2787	Ø 160	(cm. 160 x 143 h.)	lt. 1594	*●●●●

- C2
- M9*
- G9
- 87
- 86*
- D7*
- E5*



ikon

sottovaso • saucer
 untersetzer • plato • soucoupe

art. 2606 Ø 40 (cm.29 x 3 h.)	art. 2897 Ø 70 (cm.50,5x4,5h.) * ● ● ● ●	art. 2600 Ø 120 (cm. 85 x 7 h.) * ● ● ● ●
art. 2607 Ø 50 (cm.36 x 3,5h.) * ● ● ● ●	art. 2598 Ø 80 (cm. 56 x 5 h.) * ● ● ● ●	art. 2814 Ø 140 (cm. 99x8,5h.) * ● ● ● ●
art. 2608 Ø 60 (cm.42,5x 4 h.) * ● ● ● ●	art. 2599 Ø 100 (cm. 71 x 6 h.) * ● ● ● ●	art. 2815 Ø 160 (cm. 113x9,5h.) * ● ● ● ●

* colore disponibile • * color available
 * diese farbe • * color disponible • * coloris disponibles

ikon

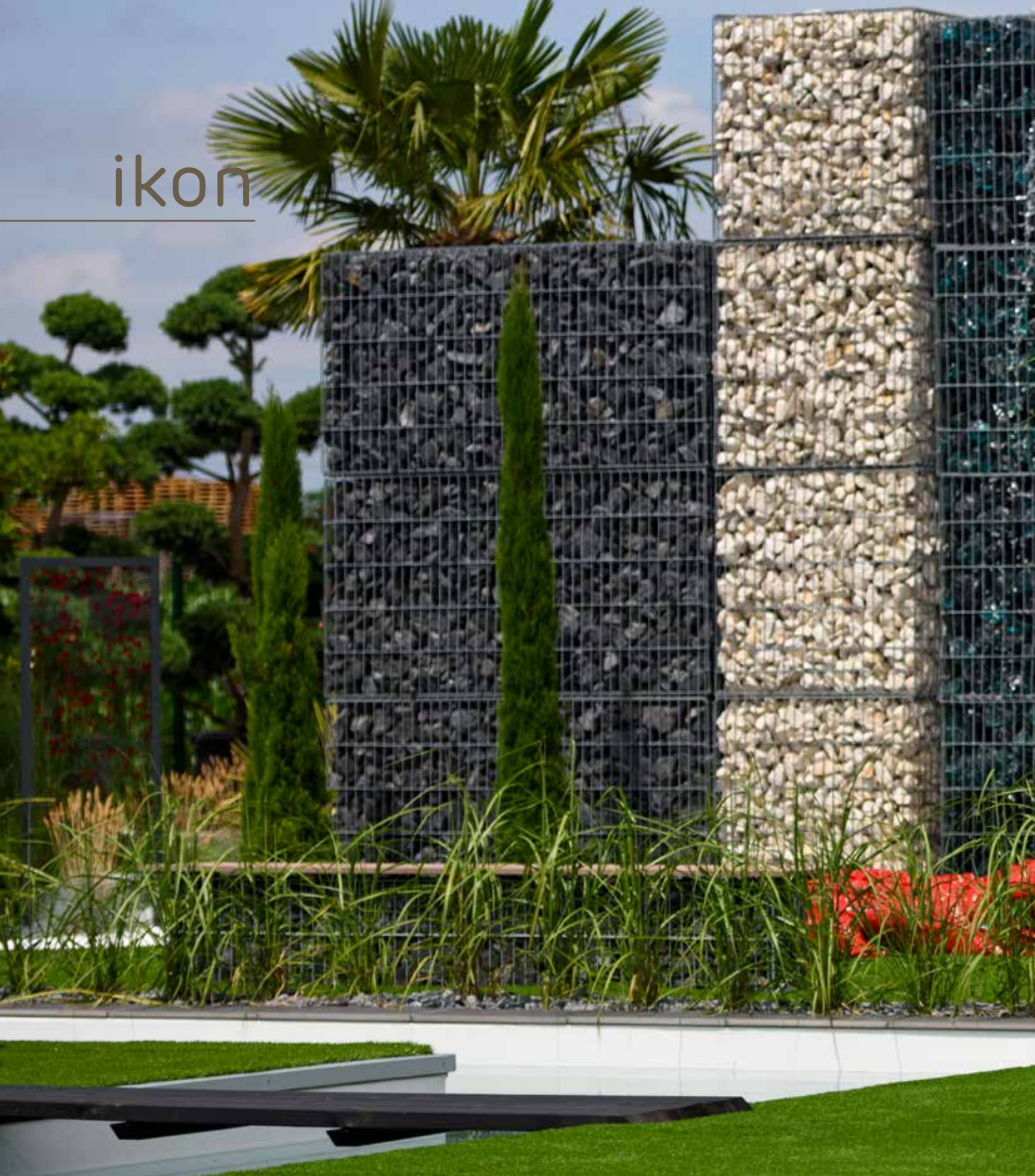

ikon

vaso con fori • pot with holes
pflanzkübel mit löchern • maceta con agujeros
pot avec des trous

art. 2996 ø 200 (cm. 200 x 178 h.) lt. 3139

ikon

sottovaso • saucer
untersetzer • plato • soucoupe

art. 3008 ø 200 (cm. 141 x 12 h.)

C2

G9

87

86

D7

E5



ikon

vaso con fori chiuso sopra • pot with holes closed on top
pflanzkübel mit löchern oben geschlossen • maceta con agujeros cerrado
pot avec des trous fermé au-dessus

art. 3012 ø 200 (cm. 200 x 178 h.) lt. 767



con fori
with holes
mit löchern
con agujeros
avec des trous

con fori
with holes
mit löchern
con agujeros
avec des trous

ilie



ilie

vaso • pot
pflanzkübel • maceta • pot

art. 2497 ø 37 (cm. 37 x 75 h.) lt. 13

art. 2498 ø 42 (cm. 42 x 90 h.) lt. 19

art. 2415 ø 47 (cm. 47 x 98 h.) lt. 26

art. 2506 ø 57 (cm. 57 x 126 h.) lt. 54

kit riserva d'acqua

water reserve kit • wasserreservoir kit
kit reserva de agua • kit réserve d'eau

art. A4256 ø 20 cap. riserva • reserve cap. lt. 1,3

art. A4239 ø 25 cap. riserva • reserve cap. lt. 2,5

art. A4240 ø 32 cap. riserva • reserve cap. lt. 4

C2

87

86

E5

C1



kiam



kiam

vaso quadro • square pot
pflanzkübel quadratisch • maceta cuadrada • pot carré

art. 2499 cm. 35 (cm. 35 x 35 x 75 h.) lt. 13

art. 2500 cm. 40 (cm. 40 x 40 x 90 h.) lt. 20

C2

87

86

E5

C1



tulum



tulum

vaso • pot
pflanzkübel • maceta • pot

art. 2373 ø 35 (cm. 35 x 51 h.) lt. 18

art. 2374 ø 43 (cm. 43 x 63 h.) lt. 33

art. 2375 ø 56 (cm. 56 x 102 h.) lt. 91

quadrum



quadrum

vaso quadro • square pot
pflanzkübel quadratisch • maceta cuadrada • pot carré

art. 2419 cm. 37 (cm. 37x37x 73h.) lt. 16

art. 2420 cm. 51 (cm. 51x51x100h.) lt. 41

etria



etria

vaso con doppia parete • pot with double wall
pflanzkübel doppelwandig • maceta con doble pared • pot avec double paroi

art. 2453 ø 24 (cm. 24x20 h.) lt. 5 *●● art. 2320 ø 54 (cm. 54 x 44 h.) lt. 56 *●●

art. 2318 ø 34 (cm. 34x28 h.) lt. 14 *●● art. 2447 ø 64 (cm. 64 x 52 h.) lt. 86

art. 2319 ø 44 (cm. 44x36 h.) lt. 30 *●● art. 2454 ø 74 (cm. 74 x 61 h.) lt. 131



* colore disponibile • * color available
* diese farbe • * color disponible • * coloris disponibles



etria uno



etria uno

vaso • pot
pflanzkübel • maceta • pot

art. 2904 ø 18 (cm.18x14,5h.) lt. 2,4 *●● art. 2863 ø 54 (cm. 54 x 44 h.) lt. 73 *●●

art. 2860 ø 24 (cm.24x20 h.) lt. 6 *●● art. 2864 ø 64 (cm. 64 x 52 h.) lt. 123

art. 2861 ø 34 (cm.34x28 h.) lt. 18 *●● art. 2865 ø 74 (cm. 74 x 61 h.) lt. 192

art. 2862 ø 44 (cm.44x36 h.) lt. 39 *●●



* colore disponibile • * color available
* diese farbe • * color disponible • * coloris disponibles





niscal

niscal

vaso • pot
pflanzkübel • maceta • pot

art. 2496 ø 37 (cm. 37 x 34 h.) lt. 12 *

art. 2484 ø 47 (cm. 47 x 43 h.) lt. 25

art. 2485 ø 57 (cm. 57 x 53 h.) lt. 45



opus

opus

vaso • pot
pflanzkübel • maceta • pot

art. 2495 ø 37 (cm. 37 x 34 h.) lt. 14 *

art. 2482 ø 47 (cm. 47 x 43 h.) lt. 26

art. 2483 ø 57 (cm. 57 x 53 h.) lt. 47

akan cassetta



akan

cassetta • plant box
pflanzkasten • jardinera • jardinière

art. 2465 cm. 80 (cm. 80x40x33h.) lt. 60

akan vaso



akan

vaso quadro • square pot
pflanzkübel quadratisch • maceta cuadrada • pot carré

art. 2486 cm. 40 (cm. 40x40x 33h.) lt. 25

kube vaso



kube

vaso • pot
pflanzkübel • maceta • pot

art. 2538 cm. 30 (cm. 30 x 30 x 30 h.) lt. 9

art. 2514 cm. 40 (cm. 40 x 40 x 40 h.) lt. 22 * ● ●

art. 2515 cm. 50 (cm. 50 x 50 x 50 h.) lt. 45 * ● ●

kube

con ruote • with rollers
mit rollen • con ruedas • avec roues

art. 2587 cm. 30 (cm. 30 x 30 x 31 h.) lt. 9

art. 2588 cm. 40 (cm. 40 x 40 x 41 h.) lt. 22 * ● ●

art. 2589 cm. 50 (cm. 50 x 50 x 51 h.) lt. 45 * ● ●

kit riserva d'acqua

water reserve kit • wasserreservoir kit
kit reserva de agua • kit réserve d'eau

art. A4255 cm. 17 cap. riserva • reserve cap. lt. 1,2

art. A4241 cm. 24 cap. riserva • reserve cap. lt. 3

art. A4242 cm. 30 cap. riserva • reserve cap. lt. 5



* colore disponibile • * color available
* diese farbe • * color disponible • * coloris disponibles



kube cassetta



kube

cassetta • plant box
pflanzkasten • jardineria • jardinière

art. 2601 cm. **80** (cm. 80x30x30h.) lt. 32

art. 2548 cm. **100** (cm. 100x40x40h.) lt. 73

kube

con ruote • with rollers
mit rollen • con ruedas • avec roues

art. 2753 cm. **80** (cm. 80x30x31h.) lt. 32

art. 2590 cm. **100** (cm. 100x40x41h.) lt. 73

kit riserva d'acqua

water reserve kit • wasserreservoir kit
kit reserva de agua • kit réserve d'eau

art. A4327 cm. **17** cap. riserva • reserve cap. lt. 3,6

art. A4278 cm. **24** cap. riserva • reserve cap. lt. 9







kube high vaso alto



kube high

vaso alto • high pot
pflanzsäule • maceta alta • pot haut

art. 2611 cm. **30** (cm. 30 x 30 x 70 h.) lt. 9

art. 2612 cm. **40** (cm. 40 x 40 x 70 h.) lt. 23

kube high

con ruote • with rollers
mit rollen • con ruedas • avec roues

art. 2733 cm. **30** (cm. 30 x 30 x 71 h.) lt. 9

art. 2734 cm. **40** (cm. 40 x 40 x 71 h.) lt. 23

kit riserva d'acqua

water reserve kit • wasserreservoir kit
kit reserva de agua • kit réserve d'eau

art. A4255 cm. **17** cap. riserva • reserve cap. lt. 1,2

art. A4241 cm. **24** cap. riserva • reserve cap. lt. 3

kube high cassetta alta



kube high

cassetta alta • high plant box
hoher pflanzkasten • jardinera alta • jardinière haute

art. 2602 cm. **80** (cm. 80x30x70 h.) lt. 32

art. 2586 cm. **100** (cm. 100x40x70 h.) lt. 77,5

kube high

con ruote • with rollers
mit rollen • con ruedas • avec roues

art. 2754 cm. **80** (cm. 80x30x71 h.) lt. 32

art. 2591 cm. **100** (cm. 100x40x71 h.) lt. 77,5

kit riserva d'acqua

water reserve kit • wasserreservoir kit
kit reserva de agua • kit réserve d'eau

art. A4327 cm. **17** cap. riserva • reserve cap. lt. 3,6

art. A4278 cm. **24** cap. riserva • reserve cap. lt. 9





kube high slim vaso alto



kube high slim

vaso alto • high pot
pflanzsäule • maceta alta • pot haut

art. 2788 cm. 25 (cm. 25x25x70 h.) lt. 8,8

kit riserva d'acqua

water reserve kit • wasserreservoir kit
kit reserva de agua • kit réserve d'eau

art. A4255 cm. 17 cap.riserva • reserve cap. lt. 1,2

C2

G9

87

86

A9

E5

kube high slim cassetta alta



kube high slim

cassetta alta • high plant box
hoher pflanzkasten • jardineria alta • jardinière haute

art. 2777 cm. 80 (cm. 80x25x70 h.) lt. 32

kit riserva d'acqua

water reserve kit • wasserreservoir kit
kit reserva de agua • kit réserve d'eau

art. A4327 cm. 17 cap.riserva • reserve cap. lt. 3,6

C2

G9

87

86

A9

E5

kube high slim modulo



kuba high slim

modulo • module
modul • módulo • module

art. 2790 cm. 25 (cm. 25 x 25 x 70 h.)*

art. 2789 cm. 80 (cm. 80 x 25 x 70 h.)*

C2

G9

87

86

43

A9

E5

* su richiesta • * upon request only

* nur auf anfrage • * solo su pedido • * sur commande uniquement



kube tower vaso alto



kube tower

vaso alto • high pot
pflanzsäule • maceta alta • pot haut

art. 2826 cm. 30 (cm.30x30x90h.) lt. 10

kit riserva d'acqua

water reserve kit • wasserreservoir kit
kit reserva de agua • kit réserve d'eau

art. A4255 cm. 17 cap.riserva • reserve cap. lt. 1,2

C2

G9

87

E5

kube tower cassetta alta



kube tower

cassetta alta • high plant box
hoher pflanzkasten • jardinera alta • jardinière haute

art. 2825 cm. 70 (cm. 70 x 30 x 90 h.) lt. 29

kit riserva d'acqua

water reserve kit • wasserreservoir kit
kit riserva de agua • kit réserve d'eau

art. A4327 cm. 17 cap. riserva • reserve cap. lt. 3,6

C2

G9

87

E5

kube panca



kube

panca • bench
bank • banco • banc

art. 2549 cm. 100 (cm.100x40x40h.)

C2

87

E5

kube sgabello



kube

sgabello • stool
hocker • taburete • tabouret

art. 2532 cm. 40 (cm. 40x40x40h.)

art. 2533 cm. 50 (cm. 50x50x50h.)



khilia special colors

Articoli caratterizzati da combinazioni di tonalità decisamente ricercate ed esclusive. Colori di intensità e sfumature sempre diverse che rendono ogni pezzo, artisticamente unico. Con "Special Colors" la collezione Khilia si arricchisce di un'anima industriale.

Items characterized by highly refined and exclusive colour combinations. The always-different intensities and shades make every item artistically unique. With "Special Colors" the Khilia collection is enriched by an industrial soul.

Artikel in ausgesprochen erlesenen, exklusiven Farbtönen, die den Ton angeben. Farben mit stets anderen Intensitäten und Nuancen, die jedes Teil zu einem einmaligen Kunstobjekt machen. Mit "Special Colors" gewinnt die Kollektion Khilia ein industrielles Motto hinzu.

Artículos caracterizados por combinaciones de tonalidades significativamente refinadas y exclusivas. Colores de intensidad y matices siempre diferentes que hacen que cada pieza sea artísticamente única. Con "Special Colors" la colección Khilia se enriquece de un alma industrial.

Des articles caractérisés par des combinaisons de tons vraiment recherchées et exclusives. Des couleurs dont les intensités et les nuances toujours différentes font de chaque article quelque chose d'unique sur le plan artistique. Avec "Special Colors", la collection Khilia s'enrichit d'une âme industrielle.

index

kube panca	p. 47 - 49
kube sgabello	p. 47 - 49
kube high cassetta alta	p. 46 - 48
kube high vaso alto	p. 46 - 48
kube tower cassetta alta	p. 46 - 48
kube tower vaso alto	p. 46 - 48

special colors





kube



kube high

cassetta alta • high plant box
hoher pflanzkasten • jardinera alta • jardinière haute

art. 2602 cm. 80 (cm. 80x30x70h.) lt. 32 *

kube high

vaso alto • high pot
pflanzsäule • maceta alta • pot haut

art. 2611 cm. 30 (cm.30x30x70h.) lt. 9 *

kube tower

cassetta alta • high plant box
hoher pflanzkasten • jardinera alta • jardinière haute

art. 2825 cm. 70 (cm.70x30x90h.) lt. 29 *

kube tower

vaso alto • high pot
pflanzsäule • maceta alta • pot haut

art. 2826 cm. 30 (cm.30x30x90h.) lt. 10 *



* su richiesta • * upon request only
* nur auf anfrage • * solo su pedido • * sur commande uniquement

kube



kube

panca • bench
bank • banco • banc

art. 2549 cm. 100 (cm.100x40x40h.)*

kube

sgabello • stool
hocker • taburete • tabouret

art. 2532 cm. 40 (cm.40x40x40h.)*



* su richiesta • * upon request only
* nur auf anfrage • * solo su pedido • * sur commande uniquement

kube



kube high

cassetta alta • high plant box
hoher pflanzkasten • jardinera alta • jardinière haute

art. 2602 cm. 80 (cm. 80x30x70h.) lt. 32 *

kube high

vaso alto • high pot
pflanzsäule • maceta alta • pot haut

art. 2611 cm. 30 (cm.30x30x70h.) lt. 9 *

kube tower

cassetta alta • high plant box
hoher pflanzkasten • jardinera alta • jardinière haute

art. 2825 cm. 70 (cm. 70x30x90h.) lt. 29 *

kube tower

vaso alto • high pot
pflanzsäule • maceta alta • pot haut

art. 2826 cm. 30 (cm.30x30x90h.) lt. 10 *

kube



kube

panca • bench
bank • banco • banc

art. 2549 cm. 100 (cm.100x40x40h.)*

kube

sgabello • stool
hocker • taburete • tabouret

art. 2532 cm. 40 (cm.40x40x40h.)*

khilia mini

Piccoli vasi colorati, da disporre in contesti sia indoor che outdoor, capaci di arredare tavoli, scrivanie, davanzali di ambienti pubblici o privati. Questa linea propone gli stessi materiali e la stessa qualità di tutti i vasi Khilia collection, in un formato ridotto.

Small coloured pots for indoor or outdoor settings to enhance tables, desks, window sills in private or public spaces. This product line proposes the same materials and quality as the pots in the Khilia collection, but in smaller sizes.

Kleine bunte Kübel für den Innen und Außen als Tisch-, Schreibtisch- oder Fensterbankdekoration privat oder in Gesellschaftsräumen. Die Artikel dieser Serie werden aus demselben, hochwertigen Material und derselben Qualität wie die Produkte der Khilia collection hergestellt – sie sind nur kleiner!

Pequeñas macetas de colores de interior y exterior, para decorar mesas, escritorios, ventanas, en ambientes públicos o privados. Esta línea ofrece los mismos materiales y la misma calidad de toda la colección de macetas Khilia, en un formato reducido.

Petits pots colorés, à installer soit à l'intérieur soit à l'extérieur, décoration de tables, bureaux, halls d'entrée des lieux publics et privés. Cette ligne de produits apporte la même qualité et est composée des mêmes matériaux que l'ensemble des pots Khilia collection, dans un format réduit.

index

mini ikon	p.	54
mini kube vaso	p.	56
mini kube cassetta	p.	58
mini kube con riserva d'acqua	p.	60
mini kube vaso con riserva d'acqua	p.	62
mini kube cassetta con riserva d'acqua	p.	62
portacassetta	p.	62





mini ikon



mini ikon

vaso • pot
pflanzkübel • maceta • pot

art. 2635 ø 20 (cm. 20x17,5 h.) lt. 1,7



mini kube vaso



mini kube

vaso • pot
pflanzkübel • maceta • pot

art. 2827 cm. 18 (cm. 18 x 18 x 18 h.) lt. 2,7

art. 2634 cm. 20 (cm. 20 x 20 x 20 h.) lt. 2,7



mini kube cassetta



mini kube

cassetta • plant box
pflanzkasten • jardineria • jardinière

art. 2828 cm. 50 (cm. 50 x 18 x 18 h.) lt. 9

art. 2776 cm. 60 (cm. 60 x 20 x 20 h.) lt. 11,5

portacassetta

bracket • halter
portajardineria • accroche

art. A4415 cm. 50 (cm. 52x26x26,5h.)

C2

G9

A2

43

A9



mini kube con riserva d'acqua





cestino riserva acqua
water reserve basket
korb für wasserreservoir
cesta reserva de agua
panier réserve d'eau



indicatore del livello dell'acqua
water level indicator
wasserstandsanzeiger
indicator del nivel de agua
indicateur de niveau d'eau



argilla espansa
expanded clay
blähton
arcilla expandida
argile expansée

indoor:

outdoor:



indicatore del livello dell'acqua
water level indicator

argilla espansa
expanded clay

cestino riserva acqua
water reserve basket

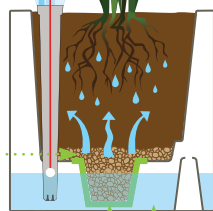

riserva d'acqua
water reserve

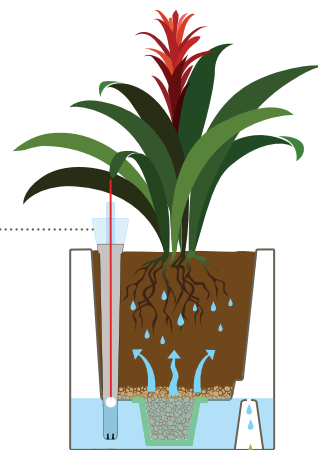
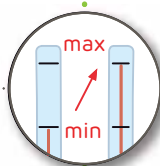

troppo pieno per uso esterno
overflow hole for outdoor use

mini kube con riserva d'acqua



mini kube

vaso con riserva d'acqua
pot with water reserve
pflanzkübel mit wasserreservoir
maceta con reserva de agua
pot avec réserve d'eau

art. 2853 cm. 18 (cm. 18 x 18 x 18 h.)

cap. riserva lt. 1 • reserve cap. lt. 1

mini kube

cassetta con riserva d'acqua
plant box with water reserve
pflanzkasten mit wasserreservoir
jardinière con reserva de agua
jardinière avec réserve d'eau

art. 2852 cm. 50 (cm. 50 x 18 x 18 h.)

cap. riserva lt. 3 • reserve cap. lt. 3

portacassetta

bracket • halter
portajardinera • accroche

art. A4415 cm. 50 (cm. 52 x 26 x 26,5 h.)

C2

G9

C2

G9

A2

43

A9



khilia gloss

Superfici lucide e colori cangianti sono le caratteristiche di questa nuova linea dal tratto giovane ma deciso.

I vasi Khilia gloss non subiscono nessun successivo processo di verniciatura, vengono prodotti direttamente nella versione lucida e colorata, pronti per arredare con la loro personalità ogni tipologia di ambiente.

Glossy surfaces and sparkling colours are the outstanding features of this new line with a young yet strong appeal.

The Khilia gloss pots do not undergo any further glazing processes as they are produced directly in the glossy coloured version ready to decorate all possible settings with their unique personality.

Glänzende Oberflächen und anziehende Farben zeichnen diese junge, klare Linie aus.

Die Khilia-gloss Serie ist nicht zusätzlich lackiert sondern wird sofort in dieser glänzenden durchgefärbten Version hergestellt - ein Blickpunkt in jeder Einrichtung.

Superficies brillantes y de colores cambiantes son la característica de ésta nueva línea joven seleccionada. El vaso Khilia gloss no experimenta ningún proceso sucesivo de lacado pero son producidos directamente en la versión lacada y coloreada, listos para diseñar con otra personalidad cualquier tipo de ambiente.

Surfaces brillantes et couleurs chatoyantes sont les caractéristiques de cette nouvelle ligne au trait jeune mais précis.

Les vases Khilia gloss ne subissent aucun processus de laquage mais sont fabriqués directement dans leur version brillante et colorée, prêts à meubler avec leur personnalité tous types de pièce.

index

ilie vaso gloss	p. 66
kiam vaso quadro gloss	p. 67
kube vaso gloss	p. 68
kuno vaso gloss	p. 69



ilie

vaso gloss • gloss pot
pflanzkübel gloss • maceta gloss • pot gloss

art. 2579 ø 32 (cm. 32 x 67 h.) lt. 9

art. 2509 ø 37 (cm. 37 x 75 h.) lt. 13

art. 2518 ø 47 (cm. 47 x 98 h.) lt. 26

art. 2580 ø 57 (cm. 57 x 126 h.) lt. 54

kit riserva d'acqua

water reserve kit • wasserreservoir kit
kit riserva de agua • kit réserve d'eau

art. A4256 ø 20 cap. riserva • reserve cap. lt. 1,3

art. A4239 ø 25 cap. riserva • reserve cap. lt. 2,5

art. A4240 ø 32 cap. riserva • reserve cap. lt. 4

kiam



kiam

vaso quadro gloss • gloss square pot
pflanzkübel quadratisch gloss • maceta cuadrada gloss • pot carré gloss

art. 2637 cm. **25** (cm. 25 x 25 x 56 h.) lt. 4,5

art. 2581 cm. **30** (cm. 30 x 30 x 67 h.) lt. 9

art. 2638 cm. **35** (cm. 35 x 35 x 75 h.) lt. 14

art. 2582 cm. **40** (cm. 40 x 40 x 90 h.) lt. 23

kit riserva d'acqua

water reserve kit • wasserreservoir kit
kit reserva de agua • kit réserve d'eau

art. A4255 cm. **17** cap.riserva • reserve.cap. lt. 1,2

art. A4373 cm. **17** cap.riserva • reserve.cap. lt. 1,2

art. A4241 cm. **24** cap.riserva • reserve.cap. lt. 3

kube



kube

vaso gloss • gloss pot
pflanzkübel gloss • maceta gloss • pot gloss

art. 2583 cm. 30 (cm. 30 x 30 x 30 h.) It. 9

art. 2584 cm. 40 (cm. 40 x 40 x 40 h.) It. 22

art. 2585 cm. 50 (cm. 50 x 50 x 50 h.) It. 45

kube

con ruote • with rollers
mit rollen • con ruedas • avec roues

art. 2592 cm. 30 (cm. 30 x 30 x 31 h.) It. 9

art. 2593 cm. 40 (cm. 40 x 40 x 41 h.) It. 22

art. 2594 cm. 50 (cm. 50 x 50 x 51 h.) It. 45

kit riserva d'acqua

water reserve kit • wasserreservoir kit
kit reserva de agua • kit réserve d'eau

art. A4255 cm. 17 cap. riserva • reserve cap. It. 1,2

art. A4241 cm. 24 cap. riserva • reserve cap. It. 3

art. A4242 cm. 30 cap. riserva • reserve cap. It. 5

kuno



kuno

vaso gloss • gloss pot
pflanzkübel gloss • maceta gloss • pot gloss

art. 2536 ø 40 (cm. 40 x 40 h.) lt. 14

art. 2534 ø 50 (cm. 50 x 50 h.) lt. 28

art. 2535 ø 60 (cm. 60 x 60 h.) lt. 52

kit riserva d'acqua

water reserve kit • wasserreservoir kit
kit riserva de agua • kit réserve d'eau

art. A4256 ø 20 cap. riserva • reserve cap. lt. 1,3

art. A4239 ø 25 cap. riserva • reserve cap. lt. 2,5

art. A4240 ø 32 cap. riserva • reserve cap. lt. 4

khilia laccati • lacquered

Una collezione dove il colore è protagonista.

Sottoposti a un elaborato processo di laccatura che assicura un risultato perfetto e duraturo nel tempo, i vasi Khilia rispondono alle esigenze di una clientela che ricerca complementi versatili e contemporanei caratterizzati dalla forza del colore e dalla potenza espressiva della finitura laccata, esclusiva e preziosa.

Colour plays a major role in this collection.

Khilia pots undergo a complex lacquered process that guarantees a perfect, long-lasting finish. Khilia pots meet the demands of customers seeking versatile, contemporary furnishing objects characterised by the force of their lacquered colour and the expressive power of their exclusive unique finish.

Die Kollektion, in der die Farbe die Hauptrolle spielt.

Diese Khilia Artikel, die eine Speziallackierung haben, die Perfektion und Dauerhaftigkeit garantiert, sind die Antwort auf die Nachfrage der Kunden, die andersartige Artikel suchen, die sich gleichzeitig durch tolle Farben ausdrucksstark charakterisieren und sich andererseits durch die Speziallackierung exklusiv und wertvoll darstellen.

Una colección donde el color es el protagonista.

Debido a un elaborado proceso de lacado que asegura un resultado perfecto y duradero en el tiempo, la maceta Khilia responde a la exigencia de una clientela que busca complementos versátiles y contemporáneos caracterizados por la fuerza del color y de la potencia expresiva del acabado lacado, exclusivo y elegante.

Une collection où la couleur est reine.

Soumis à un processus de laquage élaboré qui assure un résultat parfait et durable dans le temps, les vases Khilia Laqués répondent aux exigences d'une clientèle qui recherche des éléments éclectiques et contemporains caractérisés par la force de la couleur et la puissance exprimée par la finition laquée, exclusive et précieuse.

index

ikon vaso laccato p. 72

quadrum vaso quadro laccato p. 74



ikon

vaso laccato • lacquered pot
 pflanzkübel lackiert • maceta lacada • pot laqué

art. L2603	Ø 40	(cm. 40 x 36 h.)	lt. 23	art. L2541	Ø 80	(cm. 80 x 71 h.)	lt. 202
art. L2604	Ø 50	(cm. 50 x 44 h.)	lt. 47	art. L2542	Ø 100	(cm. 100 x 89 h.)	lt. 398
art. L2605	Ø 60	(cm. 60 x 53 h.)	lt. 82	art. L2543	Ø 120	(cm. 120 x 107 h.)	lt. 680
art. L2896	Ø 70	(cm. 70 x 62 h.)	lt. 130				



quadrum



quadrum

vaso quadro laccato • lacquered square pot
pflanzkübel quadratisch lackiert • maceta cuadrada lacado • pot carré laqué

art. L2419 cm. **37** (cm. 37x37x 73 h.) lt. 16

art. L2420 cm. **51** (cm. 51x51x100 h.) lt. 41

03*

07

D7

* su richiesta • * upon request only

* nur auf anfrage • * solo su pedido • * sur commande uniquement

khilia lights

Funzionali di giorno e scenografiche di notte, le lampade di questa collezione grazie alla possibilità di essere dotate di kit illuminanti garantiti e certificati sia per l'indoor che per l'outdoor, sanno arredare con la forza e la bellezza della luce ogni ambiente creando atmosfere suggestive ed esclusive.

Functional by day and scenographic by night, the lamps in this collection can be fitted with lighting kits that are guaranteed and certified for indoor and outdoor use. The finishing power and beauty of the light creates an exclusive and evocative atmosphere in any setting.

Funktionell am Tag und szeneträchtig während der Nacht sind die beleuchteten Elemente dieser Kollektion. Dank der Möglichkeit, aussen und innen eingesetzt zu werden durch entsprechende Beleuchtungs-Kits werden sie so zu Einrichtungsgegenständen, die durch die Kraft und die Schönheit des Lichtes jedem Ambiente eine suggestive und exklusive Atmosphäre verleihen.

Funcional de dia y escenográfica de noche, la lampara de ésta colección gracias a la posibilidad de estar dotada de kit luminoso garantiza y certifica su utliidad tanto para interior como exterior, diseñada con la fuerza y la belleza de la luz en cada ambiente, creando una atmósfera sugestiva y exclusiva.

Fonctionnelles de jour et scénographiques de nuit, les lampes de cette collection, grâce à la possibilité d'être dotées de kit lumineux garantis et certifiés aussi bien pour l'intérieur que pour l'extérieur, savent meubler toutes les pièces en créant des atmosphères suggestives et exclusives.

Tutte le lampade presenti in questo catalogo dispongono di un kit luce già installato.

All the lamps included in this catalogue are supplied with a light kit already installed.

Alle Leuchten dieses Kataloges werden inklusive eines montierten Beleuchtungs-Kits geliefert.

Todas las lámparas descritas en este catálogo disponen de un kit de luces ya instalado.

Tous les luminaireux présents dans ce catalogue sont équipés d'un kit d'éclairage déjà installé.

index

ikon light	p.	90
ilie light	p.	85
kiam light	p.	84
kube sgabello light	p.	78
kube panca light	p.	79
kube high cassetta light	p.	81
kube high vaso light	p.	80
kube high slim cassetta light	p.	93
kube high slim vaso light	p.	92
kube tower cassetta light	p.	95
kube tower vaso light	p.	94
quadrum light	p.	82
sfera light	p.	86
sfera con piedistallo light	p.	88

kube sgabello light



kube sgabello light (indoor)

art. 2705 cm. 40 (cm. 40x40x40h.)

art. 2708 cm. 50 (cm. 50x50x50h.)

kube sgabello light (outdoor)

art. 2706 cm. 40 (cm. 40x40x40h.)

art. 2709 cm. 50 (cm. 50x50x50h.)

kube rgb led light (indoor/outdoor)

art. 2707 cm. 40 (cm. 40x40x40h.)

art. 2710 cm. 50 (cm. 50x50x50h.)

kube panca light



kube panca light (indoor)

art. 2755 cm. 100 (cm.100x40x40h.)

kube panca light (outdoor)

art. 2756 cm. 100 (cm.100x40x40h.)

kube rgb led light (indoor/outdoor)

art. 2757 cm. 100 (cm.100x40x40h.)

kube high vaso light



kube high light (indoor)

art. 2737 cm. 30 (cm. 30x30x70 h.)

art. 2741 cm. 40 (cm. 40x40x70 h.)

kube high light (outdoor)

art. 2738 cm. 30 (cm. 30x30x70 h.)

art. 2742 cm. 40 (cm. 40x40x70 h.)

kube high rgb led light (indoor)

art. 2739 cm. 30 (cm. 30 x 30 x 70 h.)

art. 2743 cm. 40 (cm. 40 x 40 x 70 h.)

kube high rgb led light (outdoor)

art. 2740 cm. 30 (cm. 30x30x70 h.)

art. 2744 cm. 40 (cm. 40x40x70 h.)

kube high cassetta light



kube high light (indoor)

art. 2745 cm. **80** (cm. 80x30x70 h.)

art. 2701 cm. **100** (cm. 100x40x70 h.)

kube high light (outdoor)

art. 2746 cm. **80** (cm. 80x30x70 h.)

art. 2702 cm. **100** (cm. 100x40x70 h.)

kube high rgb led light (indoor)

art. 2747 cm. **80** (cm. 80x30x70 h.)

art. 2703 cm. **100** (cm. 100x40x70 h.)

kube high rgb led light (outdoor)

art. 2748 cm. **80** (cm. 80x30x70 h.)

art. 2704 cm. **100** (cm. 100x40x70 h.)

quadrum light



quadrum light (indoor)

quadrum light (outdoor)

quadrum rgb led light (indoor)

quadrum rgb led light (outdoor)

art. 2711 cm. 51 (cm. 51x51x100 h.)

art. 2712 cm. 51 (cm. 51x51x100 h.)

art. 2713 cm. 51 (cm. 51 x 51 x 100 h.)

art. 2714 cm. 51 (cm. 51x51x100 h.)



kiam light



kiam light (indoor)

art. 2693 cm. **35** (cm. 35 x 35 x 75 h.)

art. 2697 cm. **40** (cm. 40 x 40 x 90 h.)

kiam light (outdoor)

art. 2694 cm. **35** (cm. 35 x 35 x 75 h.)

art. 2698 cm. **40** (cm. 40 x 40 x 90 h.)

kiam rgb led light (indoor)

art. 2695 cm. **35** (cm. 35 x 35 x 75 h.)

art. 2699 cm. **40** (cm. 40 x 40 x 90 h.)

kiam rgb led light (outdoor)

art. 2696 cm. **35** (cm. 35 x 35 x 75 h.)

art. 2700 cm. **40** (cm. 40 x 40 x 90 h.)

ilie light



ilie light (indoor)

art. 2661 ø 37 (cm. 37x 75 h.)

art. 2665 ø 42 (cm. 42x 90 h.)

art. 2669 ø 47 (cm. 47x 98 h.)

art. 2673 ø 57 (cm. 57x126 h.)

ilie light (outdoor)

art. 2662 ø 37 (cm. 37x 75 h.)

art. 2666 ø 42 (cm. 42x 90 h.)

art. 2670 ø 47 (cm. 47x 98 h.)

art. 2674 ø 57 (cm. 57x126 h.)

ilie rgb led light (indoor)

art. 2663 ø 37 (cm. 37x 75 h.)

art. 2667 ø 42 (cm. 42x 90 h.)

art. 2671 ø 47 (cm. 47x 98 h.)

art. 2675 ø 57 (cm. 57x126 h.)

ilie rgb led light (outdoor)

art. 2664 ø 37 (cm. 37x 75 h.)

art. 2668 ø 42 (cm. 42x 90 h.)

art. 2672 ø 47 (cm. 47x 98 h.)

art. 2676 ø 57 (cm. 57x126 h.)

sfera light



sfera light (indoor)

art. 2639 Ø 45 (cm. 45 x 40 h.)

art. 2715 Ø 55 (cm. 55 x 50 h.)

art. 2718 Ø 65 (cm. 65 x 60 h.)

sfera light (outdoor)

art. 2651 Ø 45 (cm. 45 x 40 h.)

art. 2716 Ø 55 (cm. 55 x 50 h.)

art. 2719 Ø 65 (cm. 65 x 60 h.)

sfera rgb led light (indoor/outdoor)

art. 2749 Ø 45 (cm. 45 x 40 h.)

art. 2717 Ø 55 (cm. 55 x 50 h.)

art. 2720 Ø 65 (cm. 65 x 60 h.)



sfera con piedistallo light



sfera con piedistallo light (indoor)

art. 2759 \varnothing 65 (cm. 65 x 70 h.)

sfera con piedistallo light (outdoor)

art. 2760 \varnothing 65 (cm. 65 x 70 h.)

sfera rgb led light (indoor/outdoor)

art. 2761 \varnothing 65 (cm. 65 x 70 h.)



ikon light



ikon light (indoor)

art. 2721	Ø 40	(cm. 40 x 36 h.)
art. 2725	Ø 50	(cm. 50 x 44 h.)
art. 2729	Ø 60	(cm. 60 x 53 h.)
art. 2899	Ø 70	(cm. 70 x 62 h.)
art. 2641	Ø 80	(cm. 80 x 71 h.)
art. 2653	Ø 100	(cm. 100 x 89 h.)
art. 2657	Ø 120	(cm. 120 x 107 h.)
art. 2806	Ø 140	(cm. 140 x 125 h.)
art. 2810	Ø 160	(cm. 160 x 143 h.)

ikon light (outdoor)

art. 2722	Ø 40	(cm. 40 x 36 h.)
art. 2726	Ø 50	(cm. 50 x 44 h.)
art. 2730	Ø 60	(cm. 60 x 53 h.)
art. 2900	Ø 70	(cm. 70 x 62 h.)
art. 2642	Ø 80	(cm. 80 x 71 h.)
art. 2654	Ø 100	(cm. 100 x 89 h.)
art. 2658	Ø 120	(cm. 120 x 107 h.)
art. 2807	Ø 140	(cm. 140 x 125 h.)
art. 2811	Ø 160	(cm. 160 x 143 h.)

ikon rgb led light (indoor)

art. 2723	Ø 40	(cm. 40 x 36 h.)
art. 2727	Ø 50	(cm. 50 x 44 h.)
art. 2731	Ø 60	(cm. 60 x 53 h.)
art. 2901	Ø 70	(cm. 70 x 62 h.)
art. 2643	Ø 80	(cm. 80 x 71 h.)
art. 2655	Ø 100	(cm. 100 x 89 h.)
art. 2659	Ø 120	(cm. 120 x 107 h.)
art. 2808	Ø 140	(cm. 140 x 125 h.)
art. 2812	Ø 160	(cm. 160 x 143 h.)

ikon rgb led light (outdoor)

art. 2724	Ø 40	(cm. 40 x 36 h.)
art. 2728	Ø 50	(cm. 50 x 44 h.)
art. 2732	Ø 60	(cm. 60 x 53 h.)
art. 2902	Ø 70	(cm. 70 x 62 h.)
art. 2644	Ø 80	(cm. 80 x 71 h.)
art. 2656	Ø 100	(cm. 100 x 89 h.)
art. 2660	Ø 120	(cm. 120 x 107 h.)
art. 2809	Ø 140	(cm. 140 x 125 h.)
art. 2813	Ø 160	(cm. 160 x 143 h.)



ikon 1 kit light (outdoor)

art. 2999 ø 200 (cm. 200 x 178 h.)

ikon 1 kit rgb led light (outdoor)

art. 3001 ø 200 (cm. 200 x 178 h.)

ikon 3 kit light (outdoor)

art. 3015 ø 200 (cm. 200 x 178 h.)

ikon 3 kit rgb led light (outdoor)

art. 3016 ø 200 (cm. 200 x 178 h.)

kube high slim vaso light



kube high slim light (indoor)

kube high slim light (outdoor)

kube high slim rgb led light (indoor)

kube high slim rgb led light (outdoor)

art. 2796 cm. 25 (cm. 25 x 25 x 70 h.)

art. 2797 cm. 25 (cm. 25 x 25 x 70 h.)

art. 2798 cm. 25 (cm. 25 x 25 x 70 h.)

art. 2799 cm. 25 (cm. 25 x 25 x 70 h.)

kube high slim cassetta light



kube high slim light (indoor)

kube high slim light (outdoor)

kube high slim rgb led light (indoor)

kube high slim rgb led light (outdoor)

art. 2792 cm. 80 (cm. 80 x 25 x 70 h.)

art. 2793 cm. 80 (cm. 80 x 25 x 70 h.)

art. 2794 cm. 80 (cm. 80 x 25 x 70 h.)

art. 2795 cm. 80 (cm. 80 x 25 x 70 h.)

kube tower vaso light



kube tower light (indoor)

kube tower light (outdoor)

kube tower rgb led light (indoor)

kube tower rgb led light (outdoor)

art. 2831 cm. 30 (cm. 30 x 30 x 90 h.)

art. 2832 cm. 30 (cm. 30 x 30 x 90 h.)

art. 2833 cm. 30 (cm. 30 x 30 x 90 h.)

art. 2834 cm. 30 (cm. 30 x 30 x 90 h.)

kube tower casseta light



kube tower light (indoor)

art.2835 cm. 70 (cm. 70x30x90h.)

kube tower light (outdoor)

art.2836 cm. 70 (cm. 70x30x90h.)

kube tower rgb led light (indoor)

art.2837 cm. 70 (cm. 70 x 30 x 90 h.)

kube tower rgb led light (outdoor)

art.2838 cm. 70 (cm. 70x30x90h.)

kit led rgb light

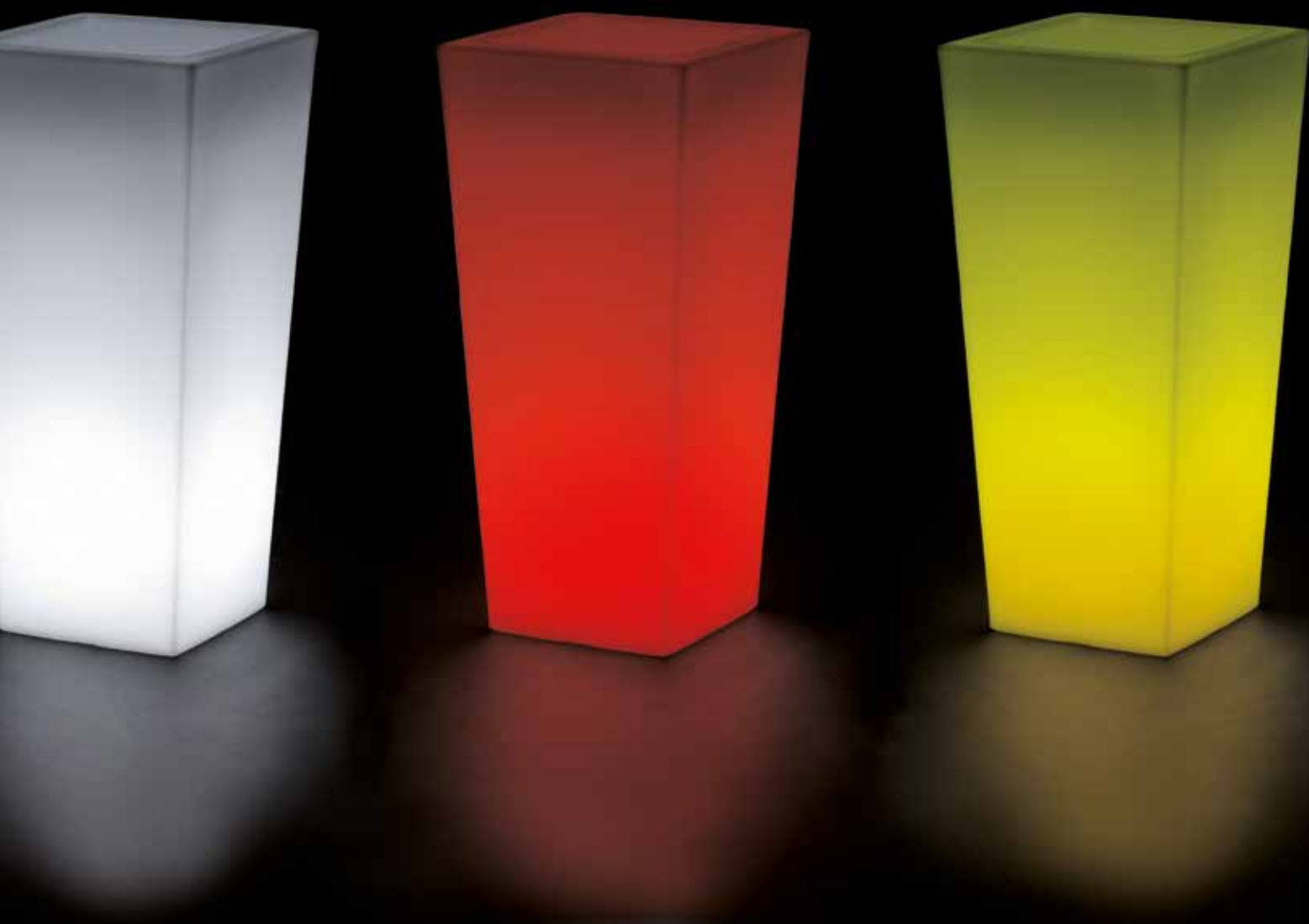

Il kit professionale applicabile a tutti i prodotti "Lights" di Khilia collection utilizza la tecnologia a risparmio energetico LED RGB, attraverso la quale è possibile trasformare ogni oggetto in una scultura luminosa e colorata. A seconda dello scenario, del contesto, o della particolare suggestione che si vuole creare, si può scegliere il colore della luce più adatto, o semplicemente lasciare che la lampada trasformi il colore lentamente in sequenza, regalando un coinvolgente spettacolo cromatico.

The professional kit, applicable to all Khilia collection "Lights", uses RGB LED technology to save energy, through which you can turn any object into a glowing colorful sculpture. Depending on the scenario, context, or that particular suggestion to be created, you can choose the most suitable light color, or simply let the lamp turn the color slowly in sequence, giving a fascinating show of color.

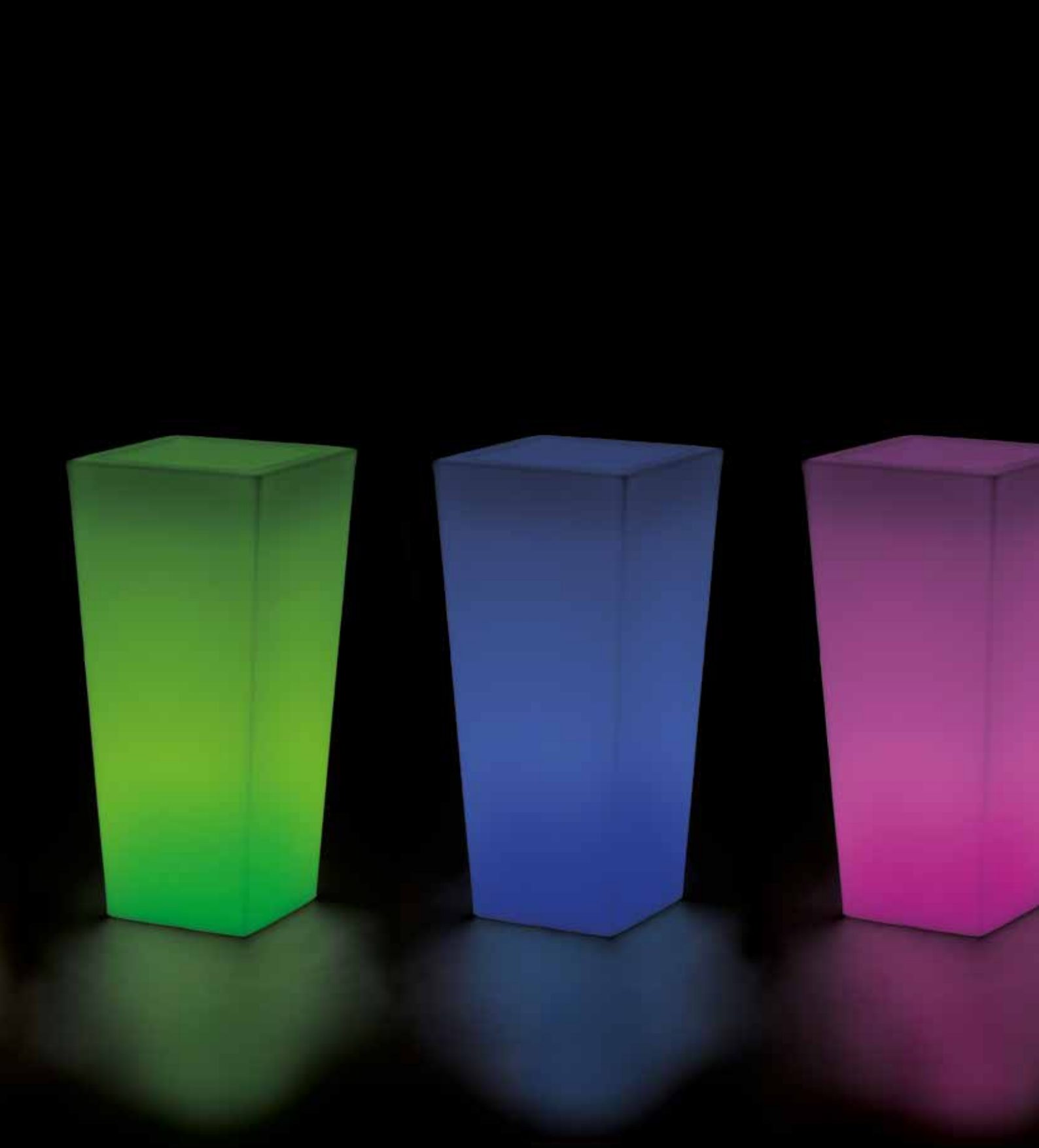

khilia mini lights

Piccoli oggetti illuminati da un kit a LED bianchi da utilizzare in svariati contesti, per arredare ricreando piccoli punti di luce d'atmosfera.

Small bright objects by a white LED kit to use in a variety of contexts, to furnish and create small points of light, conferring atmosphere.

Mit weißem LED-Kit beleuchtete kleine Objekte, vielseitig einsetzbar, um zu dekorieren, kleine "Licht-Punkte" zu setzen und Atmosphäre zu schaffen.

Pequeños objetos iluminados por un kit de LED blanco para ser utilizado en diversos contextos para decorar, recreando pequeños puntos de luz en la atmósfera.

Petits objets lumineux avec un Kit LED blanc pouvant être utilisés dans différentes lieux permettant la création de petites ambiances conviviales.

index

mini ikon light	p. 100
mini kube light	p. 102
mini kube cassetta light	p. 104
mini kube vaso light	p. 101
mini sfera light	p. 103

mini ikon light



mini ikon light (indoor)

art. 2782 ø 20 (cm. 20x17,5 h.)

mini kube vaso light



mini kube vaso light (indoor)

art. 2783 cm. 20 (cm.20x20x20 h.)

mini kube light



mini kube light (indoor)

art. 2784 cm. 20 (cm.20x20x20 h.)

mini sfera light



mini sfera light (indoor)

art. 2636 ø 20 (cm. 20 x 18 h.)

mini kube cassetta light



mini kube cassetta light (indoor)

art. 2791 cm. 60 (cm. 60 x 20 x 20 h.)

khilia kit luce

khilia kit luce per interni	p. 106
khilia kit luce per esterni	p. 107
kit led rgb per interni/esterni	p. 108
kit led rgb a batteria con spina per interni/esterni	p. 110
kit mini led light per interni	p. 112

khilia kit luce per interni

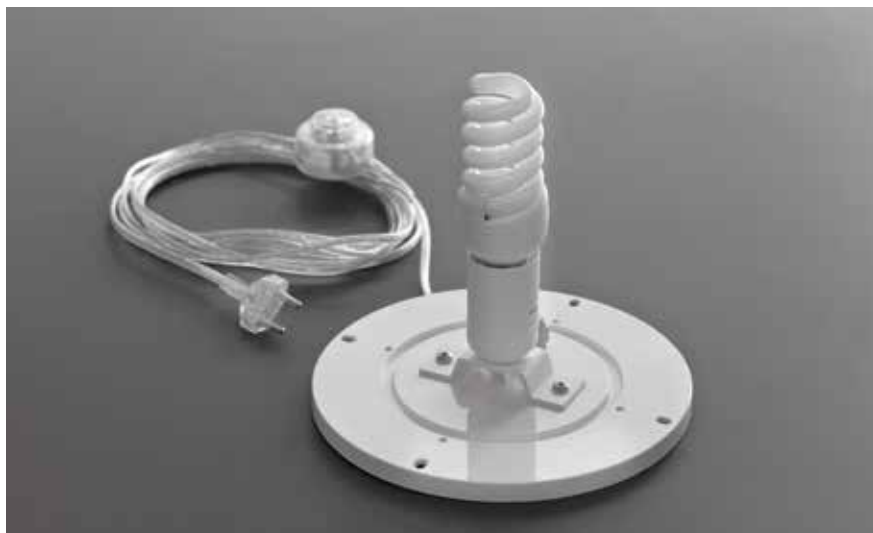

art. A4279

khilia kit luce in PC per **interni**

indoor PC khilia light kit

khilia beleuchtungs-kit aus PC für den **indoor-einsatz**

kit luz khilia en policarbonato para **interiores**

kit lumineux khilia pour l'**intérieur** en PC

dettagli • details • details • detalles • détails

piastra in policarbonato • polycarbonate plate • platte aus polycarbonat • placa de policarbonato • plaque en polycarbonate

cavo trasparente • transparent cable • transparentes kabel • cable transparente • câble transparent

pulsantiera a pedale • foot swich • fuschalter • interruptor de pie • interrupteur à pied

spina europea bipolare • european bipolar plug • bipolarer eurostecker • clavija europea bipolar • prise européenne bipolaire

lunghezza cavo • wire length • kabellnge • longitud cable • longueur du cble: **cm. 370**

luce • light • licht • luz • ampoule

1 x 20 W



E27



CE

IP 20



khilia kit luce per esterni



art. A4280

khilia kit luce in PC **per esterni**

outdoor PC khilia light kit

khilia beleuchtung-kit aus PC für den **outdoor-einsatz**

kit luz khilia en policarbonato para **exteriores**

kit lumineux khilia pour **extérieur** en PC

dettagli • details • details • detalles • détails

piastra in policarbonato • polycarbonate plate • platte aus polycarbonat • placa de policarbonato • plaque en polycarbonate

guscio in policarbonato • polycarbonate shell • hülse aus polycarbonat • carcasa de policarbonato • cloche en polycarbonate

guarnizione a tenuta • gasket seal • dichtung • junta con empaquetadura • joint d'étanchéité

cavo nero • black cable • schwarzes kabel • cable negro • câble noir

spina schuko antispruzzo • anti-splash schuko plug • spritzgeschützter schukostecker • clavija schuko antisalpicadura

prise schuko anti-éclaboussure

lunghezza cavo • wire length • kabellänge • longitud cable • longueur du câble: **cm. 280**

luce • light • licht • luz • ampoule

1 x 20 W



E27



IP 67

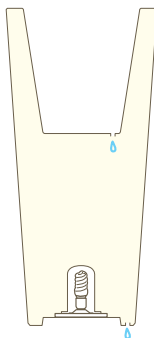

Tutti i vasi light outdoor di Khilia collection sono dotati di fori di drenaggio, all'interno e sul fondo del vaso, per favorire la fuoriuscita dell'acqua in eccesso.

All the outdoor light pots of the Khilia collection have drainage holes inside and on the base of the pot to allow excess water to drain away.

kit led rgb per interni/esterni



art. A4307

kit led rgb per **interni/esterni**
rgb led light kit **indoor/outdoor**

dettagli • details • details • detalles • détails

guscio in policarbonato • polycarbonate shell • hülse aus polycarbonat • carcasa de policarbonato • cloche en polycarbonate
telecomando • remote control • fernbedienung • control remoto • télécommande
cavo nero • black cable • schwarzes kabel • cable negro • câble noir
spina europea bipolare • european bipolar plug • bipolarer eurostecker • clavija europea bipolar • prise européenne bipolaire
trasformatore in 12V a parete • 12V wall transformer • wandtransformator 12V • transformador de 12V de pared
transformateur mural 12V
predisposizione per base di stabilizzazione • arrangement for stability base • vorrichtung für die stabilisierungsbasis
predisposición para base estabilizadora • prévu pour base stabilisante
lunghezza cavo • wire length • kabellänge • longitud cable • longueur du câble: **cm. 500**

luce • light • licht • luz • ampoule

modulo 60 led rgb 15W
15W 60 led rgb module
60 led rgb modul 15W
módulo 60 de luces led rgb de 15 W
15W 60 led rgb module



CE

IP 67

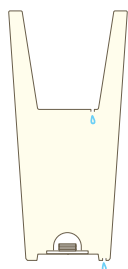

Tutti i vasi light Outdoor di Khilia collection sono dotati di fori di drenaggio, all'interno e sul fondo del vaso, per favorire la fuoriuscita dell'acqua in eccesso.

All the outdoor light pots of the Khilia collection have drainage holes inside and on the base of the pot to allow excess water to drain away.

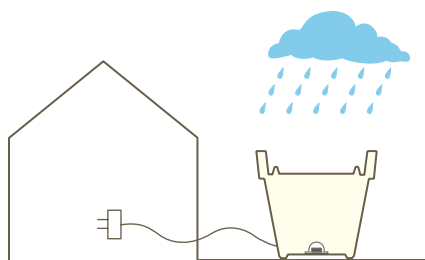

Collegare la spina dell'apparecchio in una presa collocata in un luogo protetto dalla pioggia e dagli spruzzi d'acqua.

Connect the plug of the appliance to a power outlet that is located in a sheltered position, protected from rain and water splashes.

funzionamento del telecomando a distanza

remote control operation

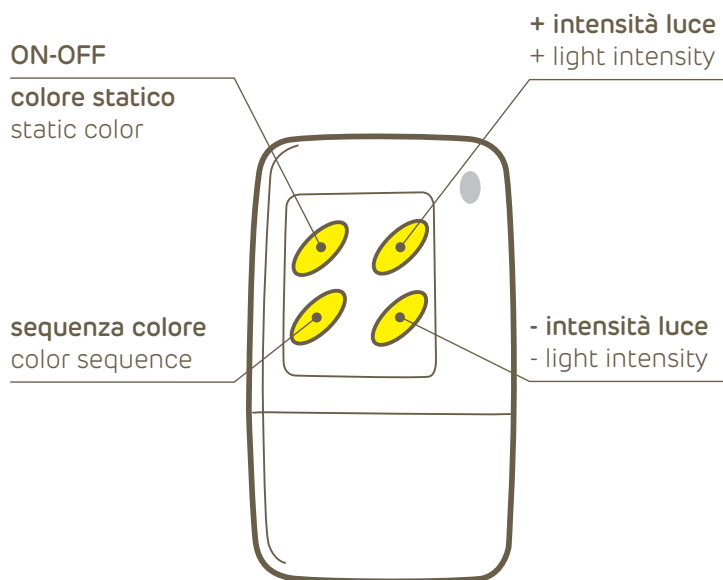

colore statico:

premendo il tasto, rgb led light cambia colore potendo scegliere tra le colorazioni bianco, verde, rosso, azzurro, giallo, fucsia.

color static:

press the button to change the colour; available colours are white, green, red blue, yellow, fuchsia.

sequenza colore:

premendo il tasto, rgb led light emette una luce che cambia colore in sfumatura, con andamento automatico ripetendo la sequenza predefinita verde, azzurro, fucsia, rosso, giallo.

color sequence:

press the colour sequence button and the rgb led light kit emits a light that fades through a colour sequence, automatically repeating the default order green, blue, fuchsia, red, yellow.

+ intensità luce:

premendo il tasto + in modalità "colore statico" aumenterà l'intensità della luce.

premendo il tasto + in modalità "sequenza colore" si aumenterà la velocità del cambio colore.

+ light intensity

press the + button to increase the light intensity during the static colour.

press the + button to increase the sequence speed during the colour sequence.

- intensità luce:

premendo il tasto • in modalità "colore statico" diminuirà l'intensità della luce.

premendo il tasto • in modalità sequenza colore si diminuirà la velocità del cambio colore.

- light intensity

press the • button to reduce the light intensity during the static colour.

press the • button to reduce the sequence speed during the colour sequence.

Ogni rgb led light kit può essere associato a 10 telecomandi, ed ogni telecomando può essere associato a un numero infinito di rgb led light kit.

Each rgb led light kit can be associated to 10 remote controls, and every remote control can be associated to an infinite number of rgb led light kits.

kit led rgb a batteria con spina



art. A4364

kit led rgb a batteria con spina per **interni/esterni**
rgb led light kit with battery with plug **indoor/outdoor**

dettagli • details • details • detalles • détails

kit led rgb powered by smart&green

autonomia 6 ore circa alla massima intensità • autonomy 6 hours on average at maximum power • laufzeit: durchschnittlich 6 stunden bei maximaler leistung • 6 horas de autonomía a la máxima intensidad • autonomie 6 heures environ en puissance maximale

telecomando • remote control • fernbedienung • control remoto • télécommande

base di ricarica con spina europea bipolare: non utilizzare in esterni e tenere al riparo dall'umidità • european bipolar plug charger: do not use outdoors and keep protected from damp and humidity • bipolarer eurostecker aufladegerät: nicht im freien und vor feuchtigkeit zu schützen • clavija europea bipolar cargado: no usar en exteriores y mantenerlo protegido contra la humedad • prise européenne bipolaire chargeur: nettoyez les contacts à l'eau, puis séchez-les avec un chiffon doux et sec.

diffusore in polietilene resistente ai raggi u.v. e agli urti • polyethylene plastic diffuser, resistant to u.v. and shocks • diffusor aus polyethylenplastik, uv beständig und stoßfest • difusor de plástico polietileno, resistente a los rayos u.v. y a los golpes • diffuseur en plastique polyéthylène, résistant aux u.v. et aux chocs

batteria li-ion polimeri 3,7V 2200 mAh • battery li-ion 3,7V 2200 mAh • akku li-ion 3,7V 2200 mAh • baterí li-ion 3,7V 2200 mAh
batterie li-ion 3,7V 2200 mAh

luce • light • licht • luz • ampoule

35 led: 20 led bianchi e 15 led colorati - 1,2 W

35 leds: 20 white leds and 15 color leds - 1,2 W

35 leds: 20 weiße leds und 15 farbige leds - 1,2 W

35 leds: 20 leds blancas y 15 leds colores - 1,2 W

35 leds: 20 leds blanches et 15 leds couleurs - 1,2 W

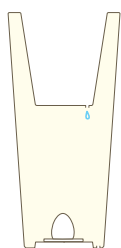

Tutti i vasi light Outdoor di Khilia collection sono dotati di fori di drenaggio, all'interno e sul fondo del vaso, per favorire la fuoriuscita dell'acqua in eccesso.

All the outdoor light pots of the Khilia collection have drainage holes inside and on the base of the pot to allow excess water to drain away.

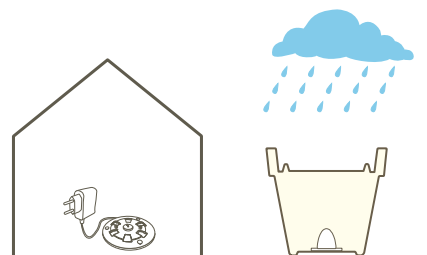

Base di ricarica con spina europea bipolare: non utilizzare in esterni e tenere al riparo dall'umidità.

European bipolar plug charger: do not use outdoors and keep protected from damp and humidity

funzionamento dei comandi nel kit rgb led light kit operation

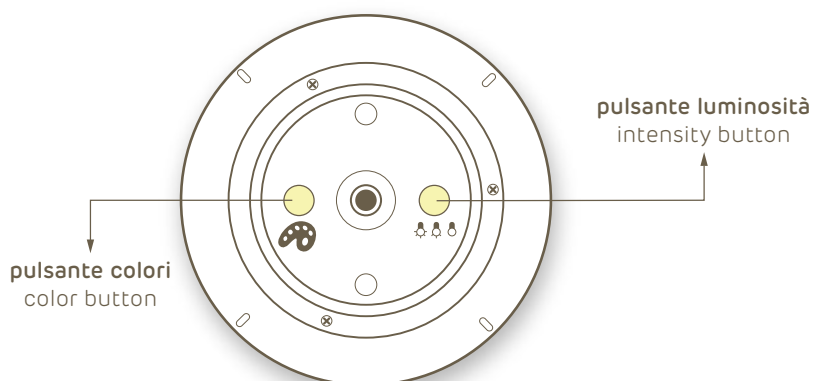

Pulsante colori • Color button

Premere questo pulsante per accendere il kit nella versione luce bianca, cambiare colore o modalità.

Press this button to turn the light on in white light, or changes the light color or mode.

scorrimento colori
scroll the colors

effetto candela blu 

candle effect - leds flicker

effetto candela 

candle effect - leds flicker



Pulsante luminosità • Intensity button

Premere questo pulsante per aumentare o diminuire l'intensità della luce

Press this button to increase or decrease the brightness of the light

funzionamento del telecomando a distanza remote control operation

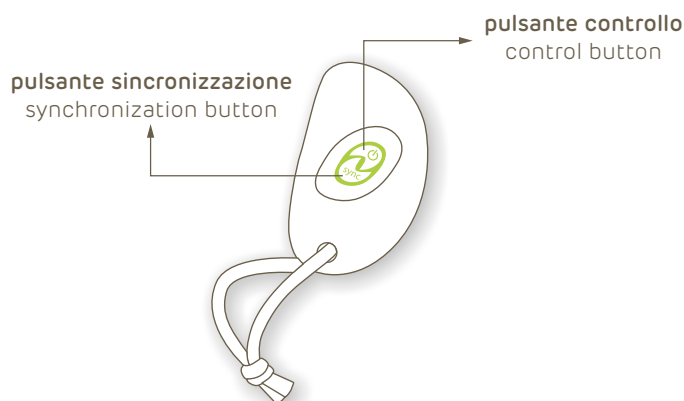

Pulsante controllo • Control button

Premere questo pulsante per accendere il kit nella versione luce bianca, o per cambiare colore o modalità. Tenere premuto per spegnere il kit.

Press this button to turn the light on in white light, or changes the light color or mode. Press and hold to switch off the light

scorrimento colori
scroll the colors

effetto candela blu 

candle effect - leds flicker

effetto candela 

candle effect - leds flicker

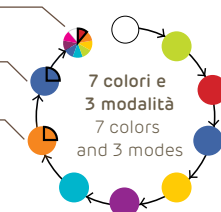

Pulsante sincronizzazione • Synchronization button

Premere questo pulsante per sincronizzare fino a 20 kit luce in un raggio d'azione di 20 metri.

Press this button to synchronizes your light kits.
Each remote control, controls 20 light kits in 20 metres of range.

kit mini led light per interni



art. A4303

Kit mini led light per **interni**
mini led light kit **indoor**

dettagli • details • details • detalles • détails

cavo trasparente • transparent cable • transparentes kabel • cable transparente • câble transparent
spina europea bipolare • european bipolar plug • bipolarer eurostecker • clavija europea bipolar • prise européenne bipolaire
trasformatore in 12V a parete • 12V wall transformer • wandtransformator 12V • transformador de 12V de pared transformateur mural 12V

pulsantiera • swich • swich • interruptor • télécommande

lunghezza cavo • wire length • kabellänge • longitud cable • longueur du câble: **cm. 140**

luce • light • licht • luz • ampoule

modulo 6 led bianchi 1,5 W

1,5 W white 6 led module
modul mit 6 weißen led's – 1,5 Watt
módulo 6 led blanco 1,5 W
module 6 led blanches 1,5 W



IP 20



khilia

utilizzo • suggestion

Khilia collection si arricchisce di una nuova serie di accessori abbinabili ai tradizionali vasi: dai Kit riserva d'acqua, disponibili in diverse forme e dimensioni, al portacassette per la cassetta mini kube da 50 cm, adatto per ornare i vostri terrazzi, fino al pratico kit posacenere che trasforma i vasi kiam gloss, kube high e kube tower in utili elementi d'arredo.

The Khilia collection is enhanced by a new whole range of accessories that can be matched with the traditional pots: from the water reserve kits, available in many shapes and sizes, to the bracket holder for the 50 cm Mini Kube plant-box, suitable for embellishing your terraces and verandas, and the handy ashtray kit, which transforms your Kiam Gloss, Kube High and Kube Tower pots into convenient furnishing items.

Die Kollektion Khilia wird um eine neue Accessoire-Serie reicher, die sich mit den traditionellen Pflanzkübeln kombinieren lässt: vom Wasservorrats-Set, das in verschiedenen Formen und Größen zu haben ist, über die Pflanzkübelhalter für die Pflanzkästen mini kube 50 cm, mit denen Sie Ihre Terrasse gestalten können, bis hin zum praktischen Aschenbecher-Set, das die Pflanzkübel kiamgloss, kube high und kubetower zu nützlichen Einrichtungsobjekten macht.

La colección Khilia se beneficia con una nueva serie de accesorios combinados con las macetas tradicionales: de los kit de reserva de agua, disponibles en distintas formas y tamaños, al posamacetas para el macetero mini kube de 50 cm, ideal para embellecer sus terrazas, hasta el práctico kit cenicero que transforma las macetas kiam gloss, kube high y kube tower en útiles elementos decorativos.

La collection Khilia s'enrichit d'une nouvelle série d'accessoires pouvant être associés aux pots et jardinières traditionnels : des kits réserve d'eau, disponibles en différentes formes et dimensions, aux accroche pour la jardinière mini kube de 50 cm, idéale pour la décoration de vos terrasses, jusqu'au kit cendrier pratique, qui transforme les pots et jardinières kiam gloss, kube high et kube tower en d'utiles éléments d'ameublement.

index

kit riserva d'acqua	p.	116
khilia utilizzo coprivaso	p.	118-122
khilia utilizzo vaso	p.	120
khilia utilizzo vaso con sottovaso	p.	123
khilia stabilità	p.	124
khilia accessori	p.	125
kit posacenere	p.	126

kit riserva d'acqua



La collezione Khilia vi propone una soluzione semplice ed intuitiva mettendo a vostra disposizione un pratico kit per dotare i vasi di un'utile riserva d'acqua. Grazie ad una griglia ed all'argilla che rilascia lentamente l'umidità all'interno del vaso, le piante possono ricevere l'acqua necessaria dall'ampio bacino sottostante, diventando autosufficienti per svariati giorni. L'unica cosa di cui vi dovrete preoccupare sarà quella di controllare di tanto in tanto il livello dell'acqua nell'indicatore.

The Khilia collection offers a simple and intuitive method by providing an easy-to-use kit for fitting pots with a very practical water reserve. The grid and clay slowly release moisture into the pot so the plants receive an adequate amount of water from the large container underneath, which makes the pot self-sufficient for several days. The only thing you have to remember is to check the water level indicator every once in a while.

Die Khilia kollektion bietet hierfür eine einfache Lösung für Sie in Form eines praktischen Kits für eine Wasserbevorratung. Dank eines Einsatzes und eines speziellen Wasserstandsanzeigers/Einfüllstutzens, der nach und nach die Feuchtigkeit in das Gefäß abgibt, können sich die Pflanzen über mehrere Tage aus dem Reservoir bedienen. Sie müssen lediglich von Zeit zu Zeit den Wasserstandanzeiger kontrollieren.

La colección Khilia le propone una solución simple e intuitiva poniendo a su disposición un práctico kit para dotar a la maceta de una útil reserva de agua. Gracias a una rejilla y una arcilla que proporciona lentamente la humedad en el interior de la maceta, la planta puede recibir el agua necesaria del depósito, abasteciéndose durante varios días. La única cosa que debe preocuparle será la de controlar de vez en cuando el nivel del agua en el indicador.

La collection Khilia vous propose une solution simple et intuitive en mettant à votre disposition un kit pratique pour équiper les pots d'une réserve d'eau utile. Grâce à une grille et à une argile qui diffuse lentement l'humidité à l'intérieur du pot, les plantes peuvent recevoir l'eau nécessaire du réservoir sous-jacent, devenant autonomes pour plusieurs jours. L'unique chose dont vous devrez vous préoccuper sera de vérifier de temps en temps le niveau d'eau sur l'indicateur.



griglia divisoria
separator
trennboden
separador
plateau de séparation

indicatore del livello dell'acqua
water level indicator
wasserstandsanzeiger
indicador del nivel de agua
indicateur de niveau d'eau

argilla espansa
expanded clay
blähton
arcilla expandida
argile expansée

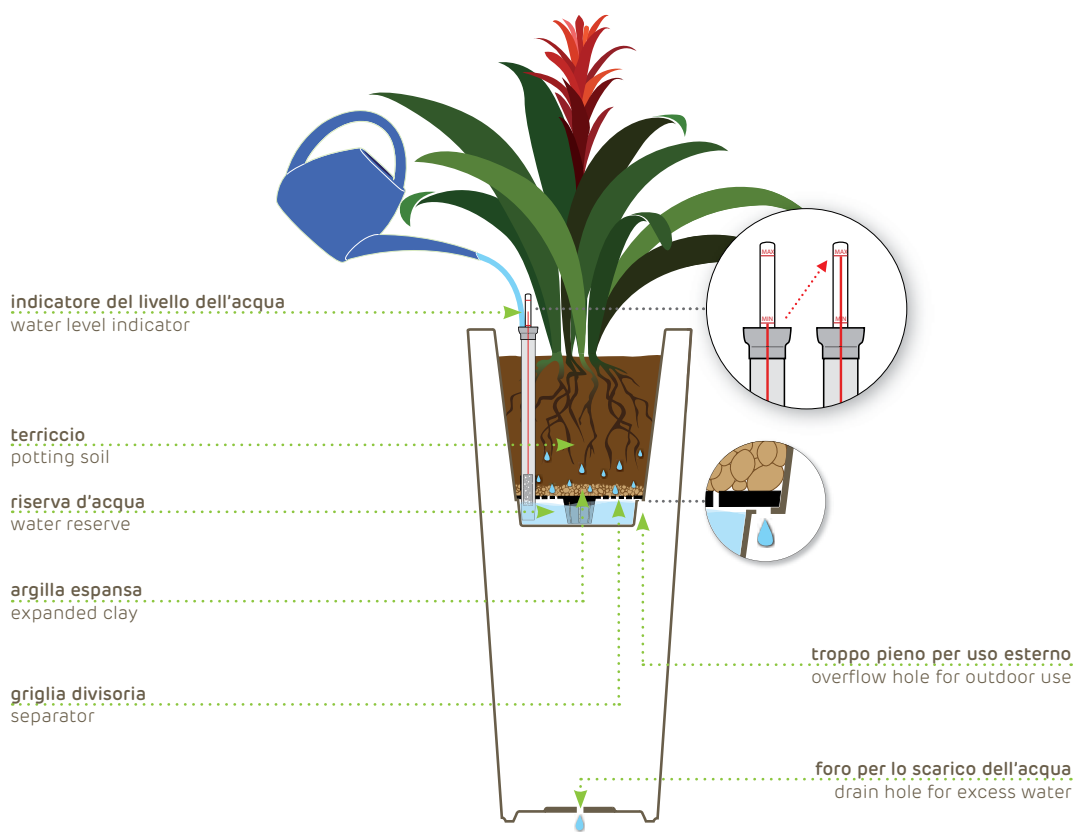

indicatore del livello dell'acqua
water level indicator

terriccio
potting soil

riserva d'acqua
water reserve

argilla espansa
expanded clay

griglia divisoria
separator

troppo pieno per uso esterno
overflow hole for outdoor use

foro per lo scarico dell'acqua
drain hole for excess water

khilia

utilizzo: coprivaso

indoor

utilizzo come **coprivaso**
used as **cachepot**
nutzung als **Übertopf**
uso como **macetero**
utilisé comme **cache-pot**

Il vaso Khilia può essere utilizzato come coprivaso. Inserire direttamente la pianta col suo contenitore d'origine all'interno del vaso Khilia: in questo modo il vaso funge da sottovaso e da riserva d'acqua.

The Khilia pot can be used as a cachepot. Place the plant with its original container inside the Khilia pot. It replaces the saucer and acts as a water reserve.

Die Kübel der Khilia Kollektion können als Übertopf verwendet werden. Setzen Sie hierzu die Pflanze mit ihrem ursprünglichen Pflanztopf direkt in den Kübel der Khilia Collection: Auf diese Weise dient der Topf als Untersetzer und Wasserreservoir.

La maceta Khilia puede utilizarse como macetero. Colocar directamente la planta con su recipiente original dentro de la maceta Khilia: de esta forma, la maceta cumple la función de plato y de reserva de agua.

Le pot Khilia peut être utilisé comme cache-pot. Introduire directement la plante dans son pot d'origine à l'intérieur du pot Khilia: le pot sert ainsi de soucoupe et de réserve d'eau.

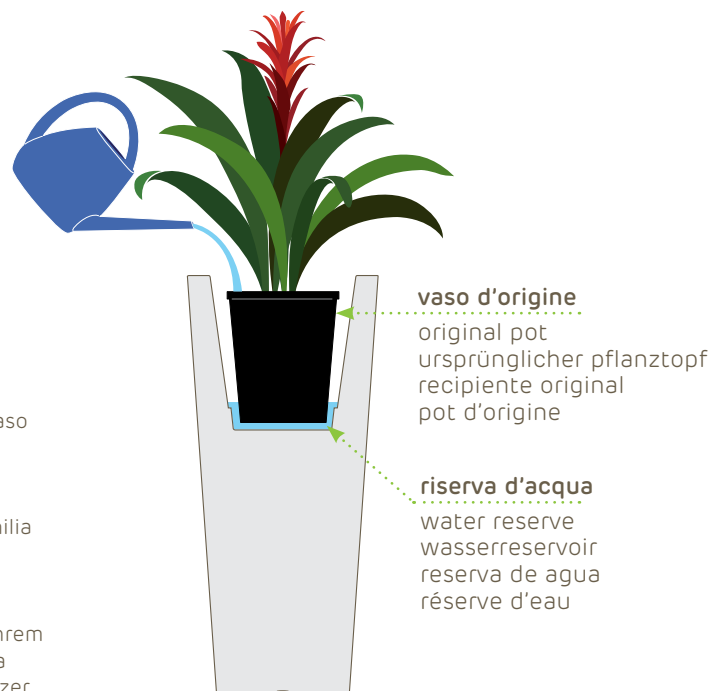

suggestion: cachepot

outdoor

utilizzo come **coprivaso**
used as **cachepot**
nutzung als **übertopf**
uso como **macetero**
utilisé comme **cache-pot**

Se il vaso viene posizionato all'esterno, praticare internamente un foro nel punto indicato, ove previsto, e togliere il tappo filettato dal fondo se presente. In caso di pioggia i fori permetteranno all'acqua in eccesso di fuoriuscire dal vaso. Quindi inserire direttamente la pianta col suo contenitore d'origine all'interno del vaso Khilia: in questo modo il vaso funge da sottovaso e da riserva d'acqua.

If the pot is used outdoors, make a hole inside at the point indicated, where indicated, and remove the screw plug, if present, from the bottom. The holes will allow excess rainwater to drain away. Place the plant with its original container inside the Khilia pot. It replaces the saucer and acts as a water reserve.

Falls der Topf im Freien verwendet werden soll, sollten Sie, soweit vorgesehen, innen an der gekennzeichneten Stelle ein Abflussloch bohren und den Schraubdeckel entfernen, soweit ein solcher. Bei Regen kann überschüssiges Wasser durch diese Löcher abfließen. Stellen Sie die Pflanze mit ihrem ursprünglichen Pflanztopf direkt in den Khilia Pflanzkübel: Auf diese Weise dient der Topf als Untersetzer und Wasserreservoir.

Si el macetero se coloca en el exterior, perforar internamente en el punto indicado previsto y quitar el tapón roscado desde el fondo, si lo hubier. En caso de lluvia los agujeros facilitarán la salida del agua en exceso. Colocar directamente la planta con su recipiente original dentro de la maceta Khilia: de esta forma, la maceta cumple la función de plato y de reserva de agua.

Si on place le pot à l'extérieur, faire un trou dedans à l'endroit indiqué, lorsque cela est prévu, et retirer le bouchon fileté du fond, s'il est mis. En cas de pluie, les orifices permettront l'écoulement de l'eau en excès. Puis introduire directement la plante dans son pot d'origine à l'intérieur du pot Khilia: le pot sert ainsi de soucoupe et de réserve d'eau.

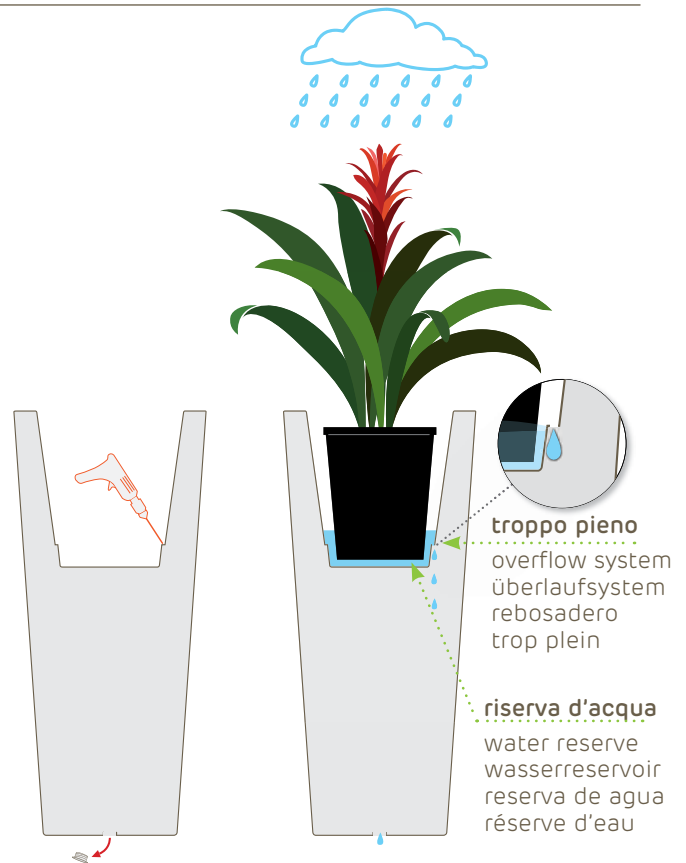

khilia

utilizzo: vaso

indoor

utilizzo come **vaso**

used as **pot**

nutzung als **pflanzkübel**

uso como **maceta**

utilisé comme **pot**

1. Versare uno strato di argilla espansa sul fondo del vaso.
 2. Stendere uno strato di tessuto-non-tessuto o di juta.
 3. Coprire quindi con uno strato di terriccio di 3-5 cm.
 4. Togliere la pianta dal suo contenitore d'origine e collocarla nel vaso Khilia.
1. Put some expanded clay into the bottom of the pot.
 2. Add a layer of non-woven fabric or hessian.
 3. Cover the expanded clay with 3-5 cm. of potting soil.
 4. Remove the plant from its original container and place it inside the Khilia pot.
1. Geben Sie eine Schicht Blähton auf den Boden des Pflanzkübels.
 2. Breiten Sie hierüber eine Schicht Vlies oder Jute aus.
 3. Bedecken Sie den Blähton dann mit einer Schicht Blumenerde (ca. 3-5 cm).
 4. Nehmen Sie nun die Pflanze aus ihrem ursprünglichen Pflanztopf und setzen Sie diese in den Khilia Pflanzkübel.
1. Disponer una capa de arcilla expandida en el fondo de la maceta.
 2. Extender una capa de tejido no tejido o de yuta.
 3. Cubrir con una capa de mantillo de humus de 3-5 cm.
 4. Quitar la planta de su recipiente original y colocarla en la maceta Khilia.
1. Verser un lit d'argile expansée sur le fond du pot.
 2. Étendre une épaisseur de tissu non tissé ou de toile de jute.
 3. Puis couvrir avec une couche de terreau de 3-5 cm.
 4. Enlever la plante de son pot d'origine et la planter dans le pot Khilia.

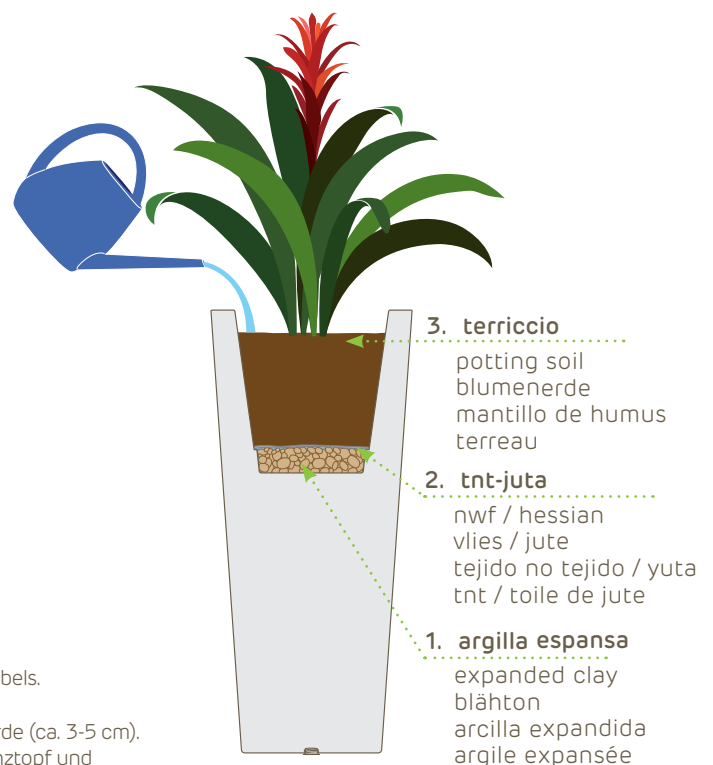

suggestion: pot

outdoor

utilizzo come **vaso**

used as **pot**

nutzung als **pflanzkübel**

uso como **maceta**

utilisé comme **pot**

1. Se il vaso viene posizionato all'esterno, praticare internamente un foro nel punto indicato, ove previsto, e togliere il tappo filettato dal fondo se presente. In caso di pioggia i fori permetteranno all'acqua in eccesso di fuoriuscire dal vaso.
2. Versare uno strato di argilla espansa sul fondo del vaso fino a coprire il foro di "troppo pieno".
3. Stendere uno strato di tessuto-non-tessuto o di juta.
4. Coprire quindi con uno strato di terriccio di 3-5 cm.
5. Collocare la pianta nel vaso.

1. If the pot is used outdoors, make a hole inside at the point indicated, where indicated, and remove the screw plug, if present. The holes will allow excess rainwater to drain away.
2. Put some expanded clay into the bottom of the pot.
3. Add a layer of hessian.
4. Cover the expanded clay with 3-5 cm. of potting soil.
5. Set the plant down into the pot.

1. Falls der Topf im Freien verwendet werden soll, sollten Sie, soweit vorgesehen, innen an der gekennzeichneten Stelle ein Abflussloch bohren und den Schraubdeckel entfernen, soweit ein solcher. Bei Regen kann überschüssiges Wasser durch diese Löcher abfließen.
2. Geben Sie eine Schicht Blähton auf den Boden des Pflanzkübels, bis das "Überlauf-Loch" bedeckt ist.
3. Breiten Sie hierüber eine Schicht Vlies oder Jute aus.
4. Bedecken Sie den Blähton dann mit einer Schicht Blumenerde (ca. 3-5 cm).
5. Nehmen Sie nun die Pflanze aus ihrem ursprünglichen Pflanztopf und setzen Sie diese in den Khilia Pflanzkübel.

1. Si el macetero se coloca en el exterior, perforar internamente en el punto indicado previsto y quitar el tapón roscado desde el fondo, si lo hubier. En caso de lluvia los agujeros facilitarán la salida del agua en exceso.
2. Disponer una capa de arcilla expandida en el fondo de la maceta hasta cubrir el agujero del rebosadero.
3. Extender una capa de tejido no tejido o de yuta.
4. Cubrir con una capa de mantillo de humus de 3-5 cm.
5. Colocar la planta en la maceta.

1. Si on place le pot à l'extérieur, faire un trou dedans à l'endroit indiqué, lorsque cela est prévu, et retirer le bouchon fileté du fond, s'il est mis. En cas de pluie, les orifices permettront l'écoulement de l'eau en excès.
2. Verser un lit d'argile expansée sur le fond du pot jusqu'à ce que l'orifice de "trop plein" soit couvert.
3. Étendre une épaisseur de tissu non tissé ou de toile de jute.
4. Puis couvrir avec une couche de terreau de 3-5 cm.
5. Planter la plante dans le pot.

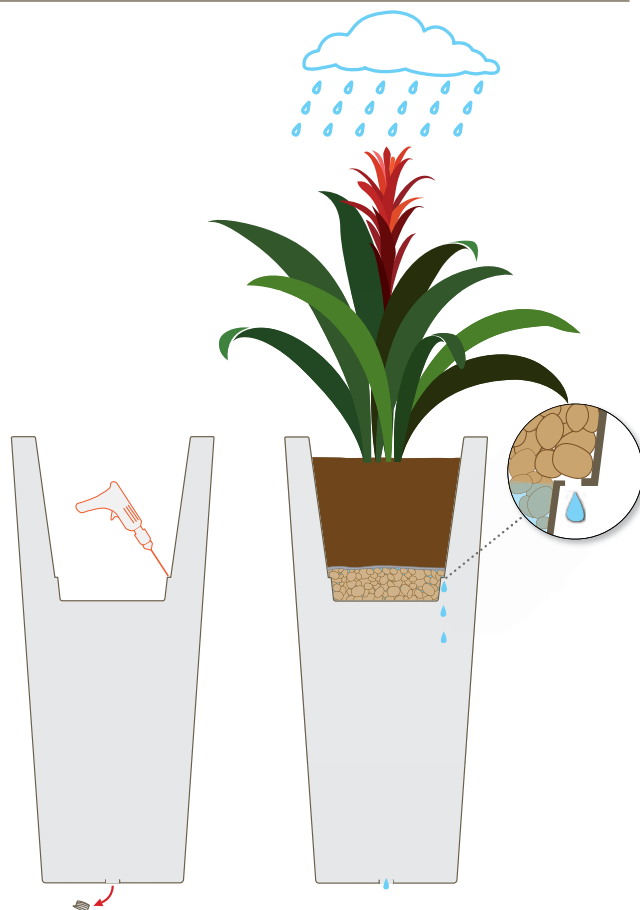

khilia

utilizzo: coprivaso

suggestions: pot cachepot

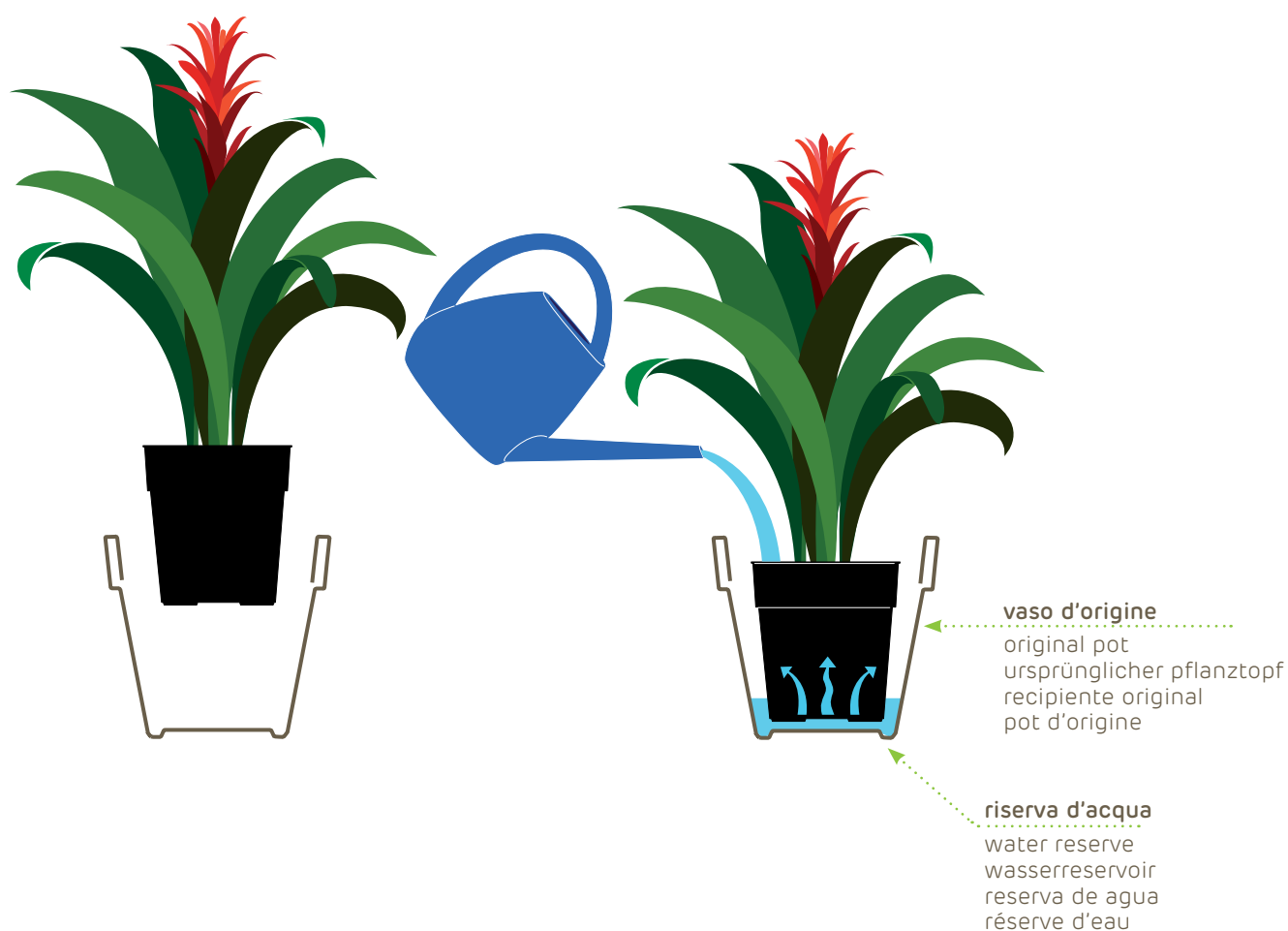

khilia

utilizzo: vaso con sottovaso

suggestions: pot with saucer

indoor

outdoor



riserva d'acqua
water reserve
wasserreservoir
reserva de agua
réserve d'eau

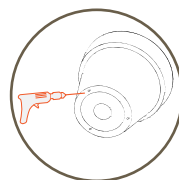

forare
drill
bohren
perforar
percer



riserva d'acqua
water reserve
wasserreservoir
reserva de agua
réserve d'eau

khilia

stabilità • stability

stabilità

extra stability • stabilität
estabilidad • stabilité

1. Per dare una maggiore stabilità al vaso, si consiglia di togliere il tappo filettato dal fondo del vaso e riempire l'interno con sabbia oppure ghiaio.
 2. In caso di esposizione al sole, per evitare che la pressione all'interno del vaso provochi modifiche nella forma, si consiglia di praticare dei fori nella parte superiore interna del vaso, consentendo così il passaggio dell'aria.
1. To give more stability to the pot remove the threaded plug from the base and fill up with sand or gravel.
 2. To prevent the pressure inside the pot from altering its shape, we recommend drilling some air vent holes around the top.
1. Um dem Pflanzkübel eine bessere Stabilität zu geben, wird empfohlen, den Gewindestopfen vom Boden des Topfs zu entfernen und das Topfinnere mit Kies zu befüllen.
 2. Damit der Druck im Inneren des Gefäßes keine Änderungen der Form verursacht, wird empfohlen, Löcher in den oberen Teil der inneren Wand zu bohren, sodass die Luft zirkulieren kann.
1. Si se desea dar una mayor estabilidad a la maceta, se aconseja quitar el tapón roscado del fondo y llenar la parte interna con gravilla.
 2. Para evitar que la presión dentro de la maceta provoque cambios en la forma, se recomienda perforarla en la parte superior interna de la misma, permitiendo así el paso del aire.
1. Pour donner plus de stabilité au pot, il est conseillé d'enlever le bouchon fileté du fond du pot et de remplir l'intérieur de gravier.
 2. Afin d'éviter qu'une pression ne crée des déformations, nous vous conseillons de faire des trous dans la partie supérieure intérieure du pot, permettant ainsi une évacuation d'air.

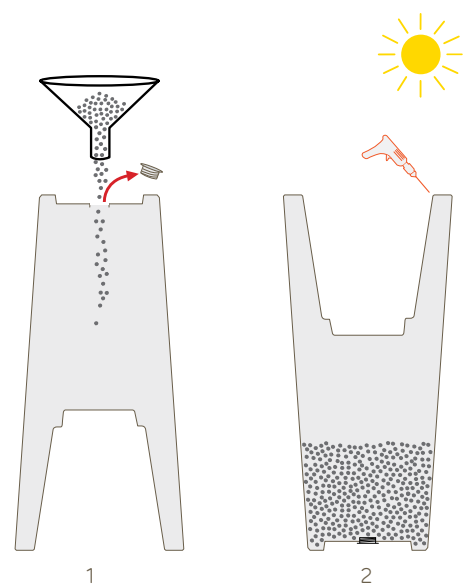

khilia accessori • accessories

ruote

rollers • rollen
ruedas • roulettes

Alcuni articoli della linea Khilia collection sono forniti di ruote a pattino con sfera in plastica per facilitarne lo spostamento.

Some articles of the Khilia Collection line are supplied with plastic ball transfers for easy moving.

Einige Artikel der Khilia Collection sind mit Kunststoff-Gleitrollen versehen, um leichter bewegt werden zu können.

Para facilitar el desplazamiento, algunos artículos de la Colección Khilia disponen de ruedas con bola de transferencia de plástico.

Certains articles de la gamme Khilia Collection sont équipés de roulettes avec roulements à billes en plastique pour en faciliter le déplacement.



portacassetta

bracket • halter
portajardinera • accroche

Portacassetta in metallo per cassetta **mini kube** cm. 50

Holder in metal for **mini kube** plant box cm. 50

Pflanzkasten-halter aus metall für kasten **mini kube** cm. 50

Portajardinera en metal para jardinera **mini kube** cm. 50

Support accroche métal pour la balconnière **mini kube** cm. 50



kit sabbia essiccata

dried sand kit • getrocknet Sand kit
kit arena seca • kit sable sèche

art. **A4601** • kg. 12



khilia kit posacenero



kit ashtray

La collezione Khilia si arricchisce di un pratico kit posacenere che dà nuova funzionalità ai vasi kiam gloss, kube high e kube tower. Grazie al posacenere in alluminio, abbinato a una paletta per ripulire la sabbia, i vasi si trasformano in utili elemento d'arredo.

The Khilia collection is enhanced with a handy ashtray kit that gives kiam gloss, kube high and kube tower pots a new feature. The pots turn into useful pieces of furniture with this aluminium ashtray and its matching sand cleaning scoop.

Die Kollektion Khilia wird um ein praktisches Aschenbecher-Set reicher, das den Pflanzkübeln kiam gloss, kube high und kube tower neue Zweckdienlichkeit verleiht. Dank der Aschenbecher aus Aluminium, zu denen eine Schaufel mit der sich der Sand säubern lässt gehört, werden die Pflanzkübel zu nützlichen Einrichtungsobjekten.

La colección Khilia se enriquece con un práctico kit cenicero que otorga nueva funcionalidad a las macetas kiam gloss, kube high e kube tower. Gracias al cenicero de aluminio, combinado con una paleta para limpiar la arena, las macetas se transforman en útiles elementos decorativos.

La collection Khilia s'enrichit d'un kit cendrier pratique, qui ajoute une nouvelle fonctionnalité aux pots kiam gloss, kube high et kube tower. Grâce au cendrier en aluminium et à la petite pelle permettant de nettoyer le sable, les pots se transforment en un élément utile d'ameublement.



posacenere
ashtray
aschenbecher
cenicero
cendrier



paletta piccola
small mat
toilettenschaufel
recogedor pequeno
pelle petite

art. A4350 kit posacenere per • ashtray kit for • kit aschenbecher für • kit cenicero para • kit cendrier pour:

kiam gloss

☒ 30

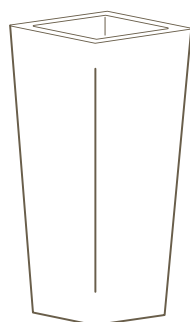

67 cm

art. 2581

kube high vaso

☒ 30



70 cm

art. 2611

kube tower vaso

☒ 30

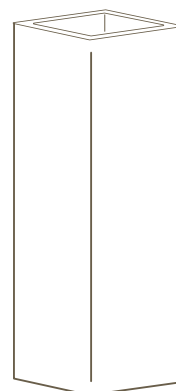

90 cm

art. 2826

khilia awvertenze

1. Tutti i prodotti sono utilizzabili sia negli spazi interni che esterni.

The entire range of products can be used indoors or outdoors.
Alle Produkte können sowohl im Indoor- als auch im Outdoor-Bereich genutzt werden.
Todos los artículos pueden utilizarse en espacios internos y externos.
Tous les produits sont utilisables à la fois pour l'intérieur que pour l'extérieur.

2. Non posizionare l'articolo su una superficie irregolare o inclinata, per evitare movimenti incontrollati.

Do not position the product on an uneven or sloping surface; this will avoid uncontrolled movements.
Stellen Sie den Artikel nicht auf eine unebenen oder schräge Fläche, um ein Umkippen des Topfes zu vermeiden.
No colocar la maceta sobre una superficie irregular o inclinada para evitar que se produzcan movimientos incontrolables.
Ne pas poser l'article sur une surface irrégulière ou inclinée afin d'en éviter les mouvements incontrôlés.

3. Tenere l'articolo lontano da fonti di calore.

Keep the article away from heat sources.
Halten Sie den Artikel von Hitzequellen fern.
Colocar la maceta lejos de fuentes de calor.
Garder l'article loin des sources de chaleur.

4. Gli articoli con pareti dritte realizzati con la tecnica "rotazionale" possono presentare delle non planarità (warpage) che potrebbero accentuarsi qualora il prodotto venisse esposto alla luce diretta del sole.

Products with straight walls made using the rotational moulding system may show some warping that could become more obvious if the pot is exposed to direct sunlight.

Artikel mit geraden Wänden, die im Rotations-Verfahren hergestellt werden, können Unebenheiten aufweisen, die sich verstärken könnten, wenn das Produkt dem direkten Sonnenlicht ausgesetzt wird.

Las macetas con paredes rectas realizadas con la técnica de rotomoldeo pueden presentar zonas onduladas que podrían acentuarse si la maceta se expone a la luz directa del sol.

Les articles aux parois carrées et/ou rectangulaires, réalisés selon la technique "rotomoulé", peuvent présenter des irrégularités dans certains cas d'exposition directe à la lumière du soleil.

5. Pulire gli articoli con una spugna bagnata con acqua e detergente liquido neutro. Risciacquare con un panno bagnato. Si raccomanda di evitare l'uso di panni abrasivi e di detergenti contenenti solventi e/o alcool etilico. In caso di sporco ostinato richiedere il detergente Euro3plast.

Clean the articles with a damp cloth and neutral liquid detergent. Rinse with a clean damp cloth. Do not use abrasive cloths or cleaning agents containing solvents and/or ethyl alcohol. For stubborn stains use the special Euro3plast detergent.

Die Artikel können mit einem nassen Schwamm und neutralem flüssigen Reinigungsmittel gereinigt werden. Bei Nutzung eines Reinigungsmittels wischen Sie den Artikel nachträglich noch einmal mit einem feuchten Tuch nach. Verwenden Sie keine Tücher, Schwämme oder Reinigungsmittel, die eine schleifende, schmirgelnde Wirkung haben sowie Lösemittel und/oder Äthylalkohol enthalten. Bei hartnäckigem Schmutz können Sie bei Euro3plast ein Reinigungsmittel anfordern.

Limpiar las macetas con una esponja mojada con agua y detergente líquido neutro. Enjuagar con una bayeta mojada. Se recomienda no utilizar bayetas abrasivas o detergentes que contengan disolventes y/o alcohol etílico. En caso de suciedad fuerte utilizar el detergente Euro3plast.

Nettoyer les articles avec une éponge mouillée d'eau et de détergent liquide neutre. Rincer avec un chiffon mouillé. Il est recommandé d'éviter l'utilisation de chiffons abrasifs et de détergents contenant des solvants et/ou de l'alcool éthylique. En cas de saleté incrustée, demander le détergent Euro3plast.

warnings

LIGHTS

1. In caso di sostituzione della lampadina, assicurarsi che la presa di corrente sia scollegata.

Before replacing a bulb make sure that the power plug has been disconnected.
Stellen Sie beim Auswechseln der Birne sicher, dass die Stromversorgung abgetrennt ist.
En caso de sustitución de la bombilla, controlar que el enchufe esté desconectado.
En cas de remplacement de l'ampoule, s'assurer que la prise est débranchée.

2. Nel caso in cui RGB LED LIGHT KIT viene smontato dal corpo lampada, evitare il contatto diretto dello sguardo con i LED accesi.

If removing the RGB LED LIGHT KIT from the lamp structure, avoid direct eye contact with the LEDs if lit up.
Falls das RGB LED BELEUCHTUNGS-KIT vom Lampenkörper demontiert wird, vermeiden Sie den direkten Blickkontakt mit den eingeschalteten LEDs.
Si el kit de luces led RGB está desmontado del cuerpo de la lámpara, evitar el contacto directo de los ojos con los led encendidos.
Au cas où le Kit d'éclairage RGB LED serait démonté du corps de la lampe, éviter le contact direct du regard avec les LED allumés.

3. Collegare la spina dell'apparecchio in una presa collocata in un luogo protetto dalla pioggia e dagli spruzzi d'acqua.

Connect the plug of the appliance to a power outlet that is located in a sheltered position, protected from rain and water splashes.
Stecken Sie den Gerätestecker in eine Steckdose, die sich an einem vor Regen und Wasserspritzern geschützten Ort befindet.
Enchufar el aparato en un enchufe protegido contra la lluvia y las salpicaduras de agua.
Brancher l'appareil à une prise située dans un endroit protégé de la pluie et des éclaboussures.

4. Se il cavo flessibile esterno di questo apparecchio viene danneggiato, deve essere sostituito esclusivamente dal costruttore, dal suo servizio di assistenza, o da personale qualificato equivalente, al fine di evitare pericoli.

If the external flexible cable of this appliance is damaged it must be replaced by either the manufacturer, the manufacturer's customer assistance service or by equivalent qualified personnel, in order to prevent possible hazards.

Wenn das biegsame äußere Kabel der Artikel beschädigt wird, darf es ausschließlich vom Kabelhersteller, von dessen Kundendienst oder von äquivalentem Fachpersonal ausgewechselt werden, um Gefahren zu vermeiden.

Para evitar peligros, si el cable flexible exterior de este aparato está dañado, lo podrá sustituir exclusivamente el fabricante, el servicio de asistencia o personal cualificado.

Si le câble souple externe de l'appareil est endommagé, le faire remplacer exclusivement par le constructeur, son service après-vente ou par du personnel qualifié équivalent, afin d'éviter tout danger.

5. Nelle versioni sprovviste di interruttore sul cavo di alimentazione, collegare la spina dell'apparecchio sotto una presa comandata da interruttore.

For models that are not equipped with an inline on/off switch, connect the plug of the appliance to a switch controlled outlet.
Verbinden Sie die Artikel, welche nicht mit Schalter am Kabel ausgestattet sind mit einer mit Schalter versehenen Steckdose.
En las versiones que no disponen de interruptor en el cable de alimentación, conectar la clavija del aparato en un enchufe accionado por interruptor.
Dans les versions exemptes d'interrupteur sur le câble d'alimentation, brancher la fiche de l'appareil à une prise commandée par un interrupteur.

6. Tutti i vasi light Outdoor di Khilia collection sono dotati di fori di drenaggio, all'interno e sul fondo del vaso, per favorire la fuoriuscita dell'acqua in eccesso. Nel caso si volesse introdurre una pianta ornamentale, si consiglia di non mettere la terra direttamente all'interno del vaso, ma posizionare un sottovaso e un vaso di contenimento per evitare ostruzioni ai fori di drenaggio e mantenere pulito l'interno del vaso.

The entire Outdoor light pots range from the Khilia collection have drain holes, inside and on the base, to allow excess water to drain away.
To avoid blocking the drainage holes and to keep the pot clean, we recommend against putting the planting medium or the plant directly in the pot; it is preferable to use the original container and place it with a saucer of suitable size in the Khilia collection pot.

Alle beleuchteten Pflanzgefäße für den Outdoor-Bereich der Khilia collection sind mit Abflusslöchern im Innern und am Boden des Topfes versehen, um ein Abfließen von überschüssigem Wasser zu ermöglichen. Um Verstopfungen an den Abflusslöchern zu vermeiden und den Pflanzkübel sauber zu halten, wird empfohlen, die Erde oder die Pflanze nicht direkt in den Topf zu geben, sondern einen separaten Topf geeigneter Abmessung, sowie einen Untersetzer in den Pflanzkübel der Khilia collection hinein zu stellen.

La parte interna y el fondo de todas las macetas Light Outdoor de la Colección Khilia disponen de agujeros de drenaje para favorecer la salida del agua en exceso. Para evitar que los agujeros de drenaje se obstruyan y para mantener la maceta limpia, se aconseja no poner tierra ni colocar la planta directamente dentro de la maceta, sino colocar un plato o el recipiente original de la planta cuyas dimensiones sean adecuadas a la maceta de la Colección Khilia.

Tous les pots lumineux Outdoor de Khilia collection sont équipés d'orifices de drainage, à l'intérieur et sur le fond, pour favoriser l'écoulement de l'eau en excès. Pour éviter que les orifices de drainage ne se bouchent et garder le pot propre, il est conseillé de ne pas mettre la terre ou la plante directement dans le pot, mais de mettre un pot et un dessous de pot aux dimensions adéquates dans le pot Khilia collection.

khilia merchandising tools

Per i clienti, la visibilità dei prodotti e dei servizi è di massima importanza durante l'acquisto! Euro3plast è in grado di fornire attrezzature innovative per realizzare diverse soluzioni espositive. Il visual Merchandising è dinamico, in continuo cambiamento ed è essenziale usare le tecniche più aggiornate per incrementare le prestazioni di vendita. Sono a vostra disposizione teli da appendere, totem da terra e copripallet per creare pedane di diverse misure, atte ad esporre i prodotti euro3plast!

Product visibility and services are of crucial importance for customers when making a purchase! Euro3plast can provide innovative tools for creating various display solutions. Visual merchandising is dynamic, continually changing and the use of cutting edge techniques is vital to ensure increased sales performance. We can supply hanging banners, floor standing totems and cover pallet to create platforms of various sizes for displaying euro3plast products!

Für den Kunden ist die Optik der Produkte und die Service-Leistung während des Einkaufs von größter Wichtigkeit! Euro3plast ist in der Lage, innovative Merchandising-Instrumente anzubieten. "Visual Merchandising" ist dynamisch und in ständiger Veränderung begriffen. Es ist von grundlegender Bedeutung, die aktualisiertesten Techniken einzusetzen, um die Verkaufsleistungen zu erhöhen. Zu Ihrer Verfügung stehen Banner, Aufsteller und Palettenabdeckungen, um Stellflächen mit verschiedenen Abmessungen zu kreieren, auf denen die Produkte von euro3plast präsentiert werden können!

¡Para los clientes, es fundamental la exposición de los productos y la presentación clara de los servicios durante la compra! Euro3plast puede proporcionar herramientas innovadoras para realizar distintas soluciones expositivas. El mercado visual es dinámico y en continua evolución, y es esencial utilizar las técnicas más actualizadas para incrementar las prestaciones de venta. ¡Se dispone también de pancartas para colgar, tótem para apoyar en el suelo y cubrepalets que crean tarimas de distintas medidas, idóneas a la exposición de los productos euro3plast!

Pour les clients, la visibilité des produits et des services est d'une extrême importance lors de l'achat! Euro3plast est en mesure de fournir des équipements innovants pour réaliser différentes solutions d'exposition. Le merchandising visuel est dynamique, continuellement en évolution et il est essentiel d'utiliser des techniques à jour pour augmenter les actions de vente. Des toiles à suspendre, des totems à poser au sol et des habillage-palet sont à votre disposition pour créer des estrades de différentes dimensions, en mesure d'exposer les produits euro3plast!



telo khilia

hanging banner
banner • lona • toile tendue

collection		gloss		light	
art. ET263	(cm. 60 x 185 h.)	art. ET264	(cm. 60 x 185 h.)	art. ET265	(cm. 60 x 185 h.)
art. ET243	(cm. 150 x 185 h.)	art. ET244	(cm. 150 x 185 h.)	art. ET245	(cm. 150 x 185 h.)
art. ET240	(cm. 240 x 300 h.)	art. ET241	(cm. 240 x 300 h.)	art. ET242	(cm. 240 x 300 h.)



cover pallet

art. ET225 (cm. 121 x 81 x 14 h.)



totem khilia

art. ET390 (cm. 50 x 154 h.)

khilia collection





khilia collection





khilia collection





khilia collection

dati tecnici

technical data

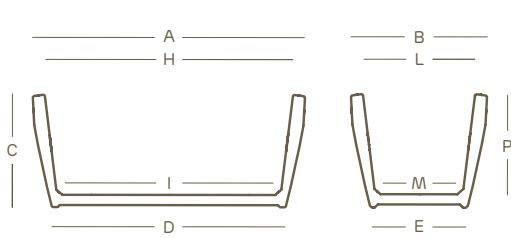

Art. 2465
cm. 80

A	cm. 80	H	cm. 73
B	cm. 40	I	cm. 65
C	cm. 33	L	cm. 33
D	cm. 69	M	cm. 25
E	cm. 28	P	cm. 29

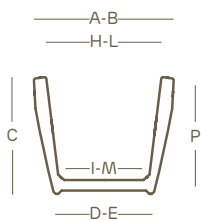

Art. 2486
cm. 40

A-B	cm. 40
C	cm. 33
D-E	cm. 28
H-L	cm. 33
I-M	cm. 25
P	cm. 29

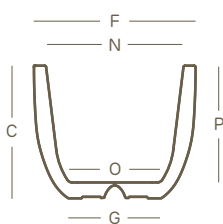

Art. 2453	Art. 2318	Art. 2319	Art. 2320	Art. 2447	Art. 2454
ø cm. 24	ø cm. 34	ø cm. 44	ø cm. 54	ø cm. 64	ø cm. 74
C cm. 20	C cm. 28	C cm. 36	C cm. 44	C cm. 52	C cm. 61
F cm. 24	F cm. 34	F cm. 44	F cm. 54	F cm. 64	F cm. 74
G cm. 14	G cm. 19	G cm. 25	G cm. 31	G cm. 37	G cm. 43
N cm. 20	N cm. 29	N cm. 37	N cm. 46	N cm. 54	N cm. 63
O cm. 13	O cm. 19	O cm. 26	O cm. 33	O cm. 37	O cm. 42
P cm. 18	P cm. 25	P cm. 32	P cm. 39	P cm. 46	P cm. 53

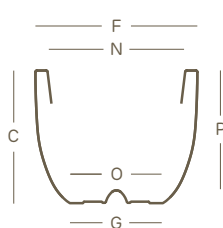

Art. 2904	Art. 2860	Art. 2861	Art. 2862	Art. 2863	Art. 2864	Art. 2865
ø cm. 18	ø cm. 24	ø cm. 34	ø cm. 44	ø cm. 54	ø cm. 64	ø cm. 74
C cm. 14	C cm. 20	C cm. 28	C cm. 36	C cm. 44	C cm. 52	C cm. 61
F cm. 18	F cm. 24	F cm. 34	F cm. 44	F cm. 54	F cm. 64	F cm. 74
G cm. 11	G cm. 14	G cm. 19	G cm. 25	G cm. 31	G cm. 37	G cm. 43
N cm. 15	N cm. 20	N cm. 29	N cm. 37	N cm. 46	N cm. 54	N cm. 63
O cm. 10	O cm. 13	O cm. 19	O cm. 26	O cm. 33	O cm. 37	O cm. 42
P cm. 12	P cm. 18	P cm. 25	P cm. 32	P cm. 39	P cm. 46	P cm. 53

ilie

pag. 10

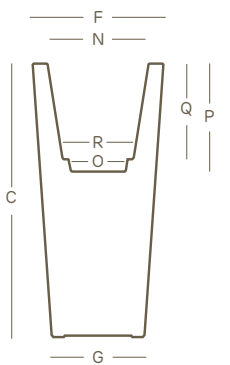

Art. 2497	Art. 2498	Art. 2415	Art. 2506
ø cm. 37	ø cm. 42	ø cm. 47	ø cm. 57
C cm. 75	C cm. 90	C cm. 98	C cm. 126
F cm. 37	F cm. 42	F cm. 47	F cm. 57
G cm. 26	G cm. 29	G cm. 33	G cm. 40
N cm. 28	N cm. 33	N cm. 36	N cm. 44
O cm. 15	O cm. 24	O cm. 20	O cm. 28
P cm. 33	P cm. 31	P cm. 41	P cm. 50
Q cm. 27		Q cm. 35	Q cm. 44
R cm. 20		R cm. 25	R cm. 32

ikon

pag. 6

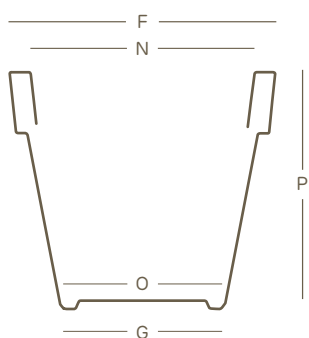

Art. 2603	Art. 2604	Art. 2605	Art. 2896	Art. 2541
ø cm. 40	ø cm. 50	ø cm. 60	ø cm. 70	ø cm. 80
C cm. 36	C cm. 44	C cm. 53	C cm. 62	C cm. 71
F cm. 40	F cm. 50	F cm. 60	F cm. 70	F cm. 80
G cm. 23	G cm. 29	G cm. 35	G cm. 42	G cm. 47
N cm. 34	N cm. 43	N cm. 52	N cm. 60	N cm. 69
O cm. 25	O cm. 30	O cm. 36	O cm. 41	O cm. 50
P cm. 33	P cm. 42	P cm. 51	P cm. 59	P cm. 70

ikon

pag. 6 - 8

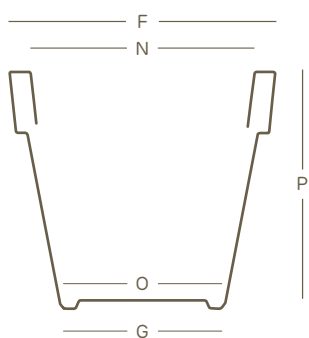

Art. 2542	Art. 2543	Art. 2786	Art. 2787	Art. 2996
ø cm. 100	ø cm. 120	ø cm. 140	ø cm. 160	ø cm. 200
C cm. 89	C cm. 107	C cm. 125	C cm. 143	C cm. 178
F cm. 100	F cm. 120	F cm. 140	F cm. 160	F cm. 200
G cm. 59	G cm. 72	G cm. 85	G cm. 97	G cm. 120
N cm. 86	N cm. 103	N cm. 120	N cm. 138	N cm. 172
O cm. 61	O cm. 72	O cm. 83	O cm. 95	O cm. 119
P cm. 88	P cm. 106	P cm. 124	P cm. 142	P cm. 173

ikon

pag. 9

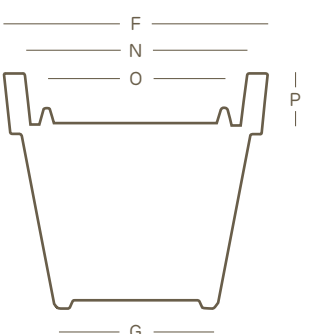

Art. 3012
ø cm. 200
C cm. 178
F cm. 200
G cm. 120
N cm. 172
O cm. 124
P cm. 40

kiam

pag. 12

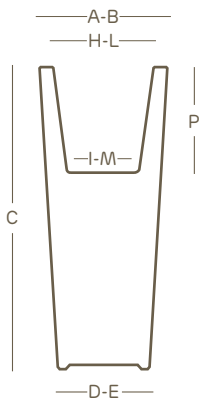

Art. 2499
cm. 35

Art. 2500
cm. 40

A-B	cm. 35	A-B	cm. 40
C	cm. 75	C	cm. 90
D-E	cm. 25	D-E	cm. 28
H-L	cm. 26	H-L	cm. 30
I-M	cm. 20	I-M	cm. 23
P	cm. 24	P	cm. 28

kube cassetta • plant box

pag. 26

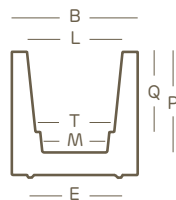
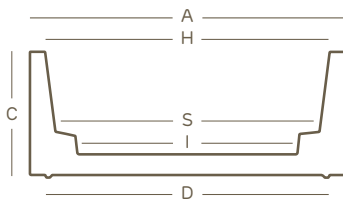

Art. 2601
cm. 80

Art. 2548
cm. 100

A	cm. 80	L	cm. 22	A	cm. 100	L	cm. 30
B	cm. 30	M	cm. 14	B	cm. 40	M	cm. 19
C	cm. 30	P	cm. 25	C	cm. 40	P	cm. 34
D	cm. 72	Q	cm. 19	D	cm. 90	Q	cm. 28
E	cm. 22	S	cm. 51	E	cm. 29	S	cm. 72
H	cm. 73	T	cm. 17	H	cm. 90	T	cm. 24
I	cm. 49			I	cm. 70		

kube panca • bench

pag. 40

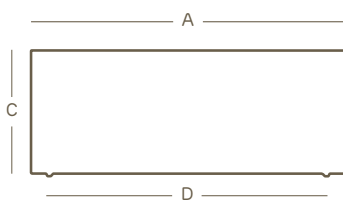

Art. 2549
cm. 100

A	cm. 100
B	cm. 40
C	cm. 40
D	cm. 90
E	cm. 29

kube sgabello • stool

pag. 41

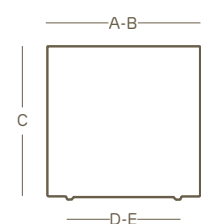

Art. 2532
cm. 40

Art. 2533
cm. 50

A	cm. 40	A	cm. 50
B	cm. 40	B	cm. 50
C	cm. 40	C	cm. 50
D	cm. 29	D	cm. 37
E	cm. 29	E	cm. 37

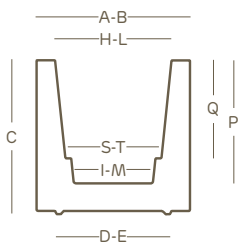

Art. 2538	Art. 2514	Art. 2515
cm. 30	cm. 40	cm. 50
A-B cm. 30	A-B cm. 40	A-B cm. 50
C cm. 30	C cm. 40	C cm. 50
D-E cm. 22	D-E cm. 29	D-E cm. 37
H-L cm. 23	H-L cm. 30	H-L cm. 38
I-M cm. 14	I-M cm. 19	I-M cm. 25
P cm. 25	P cm. 32	P cm. 40
Q cm. 18	Q cm. 26	Q cm. 34
S-T cm. 17	S-T cm. 24	S-T cm. 30

kube high cassetta alta • high plant box

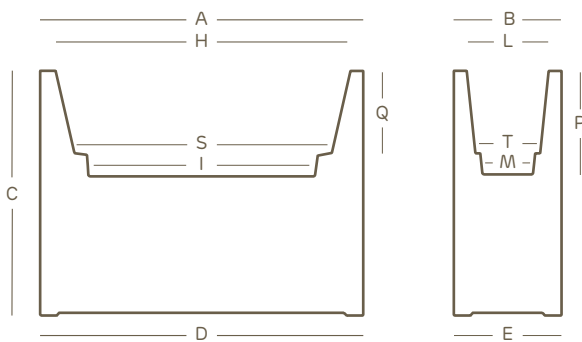

Art. 2602	Art. 2586
cm. 80	cm. 100
A cm. 80	A cm. 100
B cm. 30	B cm. 40
C cm. 70	C cm. 70
D cm. 80	D cm. 100
E cm. 30	E cm. 40
H cm. 73	H cm. 90
I cm. 49	I cm. 70
L cm. 22	L cm. 30
M cm. 14	M cm. 19
P cm. 25	P cm. 34
Q cm. 19	Q cm. 30
S cm. 51	S cm. 72
T cm. 17	T cm. 24

kube high vaso alto • high pot

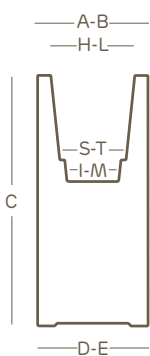

Art. 2611	Art. 2612
cm. 30	cm. 40
A-B cm. 30	A-B cm. 40
C cm. 70	C cm. 70
D-E cm. 29	D-E cm. 39
H-L cm. 23	H-L cm. 30
I-M cm. 14	I-M cm. 19
P cm. 25	P cm. 33
Q cm. 18	Q cm. 26
S-T cm. 17	S-T cm. 24

kube high slim cassetta alta • high plant box

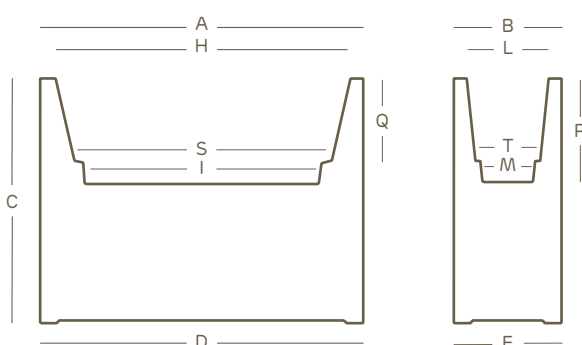

Art. 2777
cm. 80
A cm. 80
B cm. 25
C cm. 70
D cm. 80
E cm. 25
H cm. 75
I cm. 49
L cm. 20
M cm. 14
P cm. 26,5
Q cm. 20
S cm. 68
T cm. 18

kube high slim modulo • module

pag. 36

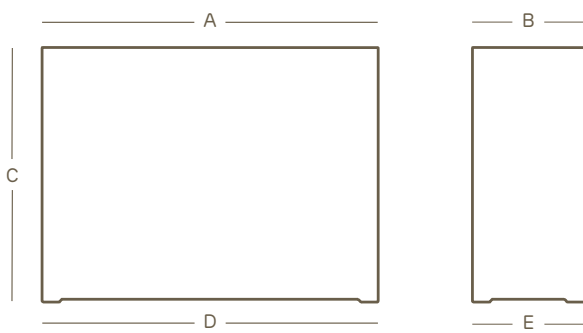

Art. 2789
cm. 80

A cm. 80
B cm. 25
C cm. 70
D cm. 80
E cm. 25

kube high slim modulo • module

pag. 36

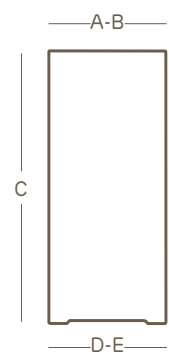

Art. 2790
cm. 25

A-B cm. 25
C cm. 70
D-E cm. 25

kube high slim vaso alto • high pot

pag. 34

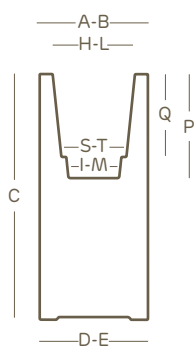

Art. 2788
cm. 25

A-B cm. 25
C cm. 70
D-E cm. 25
H-L cm. 20
I-M cm. 14
P cm. 26,5
Q cm. 20
S-T cm. 18

kube tower cassetta alta • high plant box

pag. 39

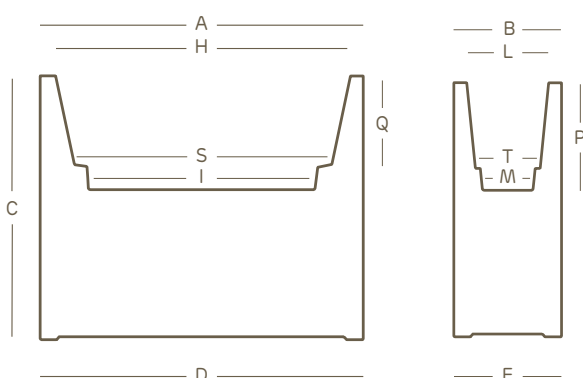

Art. 2825
cm. 70

A cm. 70
B cm. 30
C cm. 90
D cm. 70
E cm. 30
H cm. 63
I cm. 49,5
L cm. 23
M cm. 14
P cm. 26,5
Q cm. 20
S cm. 53
T cm. 20

kube tower vaso alto • high pot

pag. 38

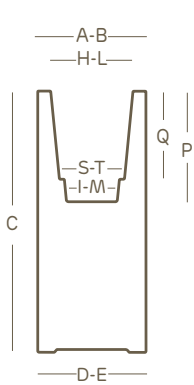

Art. 2826
cm. 30

A-B cm. 30
C cm. 90
D-E cm. 30
H-L cm. 23
I-M cm. 14
P cm. 26,5
Q cm. 20
S-T cm. 18

niscal

pag. 20

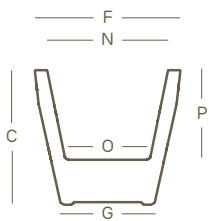

Art. 2496 Art. 2484 Art. 2485
ø cm. 37 ø cm. 47 ø cm. 57

C cm. 34	C cm. 43	C cm. 53
F cm. 37	F cm. 47	F cm. 57
G cm. 22	G cm. 31	G cm. 37
N cm. 31	N cm. 39	N cm. 47
O cm. 19	O cm. 24	O cm. 29
P cm. 23	P cm. 28	P cm. 35

opus

pag. 21

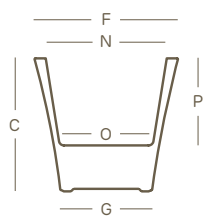

Art. 2495 Art. 2482 Art. 2483
ø cm. 37 ø cm. 47 ø cm. 57

C cm. 34	C cm. 43	C cm. 53
F cm. 37	F cm. 47	F cm. 57
G cm. 22	G cm. 30	G cm. 36
N cm. 31	N cm. 39	N cm. 47
O cm. 21	O cm. 30	O cm. 36
P cm. 26	P cm. 28	P cm. 34

quadrum

pag. 15

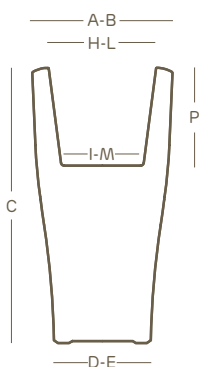

Art. 2419 Art. 2420
cm. 37 cm. 51

A-B cm. 37	A-B cm. 51
C cm. 73	C cm. 100
D-E cm. 26	D-E cm. 35
H-L cm. 29	H-L cm. 39
I-M cm. 22	I-M cm. 30
P cm. 27	P cm. 35

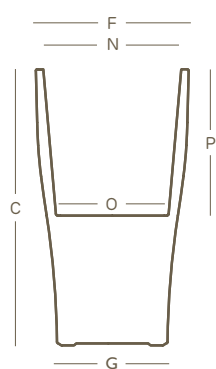

Art. 2373	Art. 2374	Art. 2375
ø cm. 35	ø cm. 43	ø cm. 56
C cm. 51	C cm. 63	C cm. 102
F cm. 35	F cm. 43	F cm. 56
G cm. 24	G cm. 29	G cm. 41
N cm. 32	N cm. 39	N cm. 51
O cm. 25	O cm. 30	O cm. 42
P cm. 29	P cm. 35	P cm. 54

khilia mini

dati tecnici

technical data

mini ikon

pag. 54

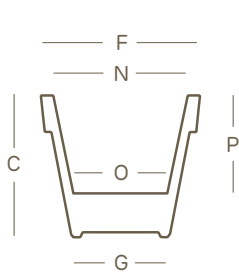

Art. 2635
 ø cm. 20

C cm. 17,5
 F cm. 20
 G cm. 11,5
 N cm. 16
 O cm. 11
 P cm. 12

mini kube vaso • pot

pag. 56

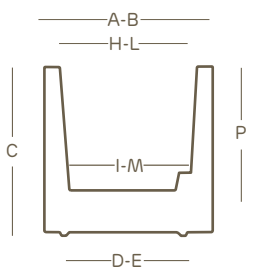

Art. 2827
 cm. 18

Art. 2634
 cm. 20

A-B	cm. 18	A-B	cm. 20
C	cm. 18	C	cm. 20
D-E	cm. 14	D-E	cm. 15
H-L	cm. 15	H-L	cm. 15
I-M	cm. 13	I-M	cm. 12
P	cm. 14	P	cm. 14,5

mini kube vaso con riserva d'acqua • pot with water reserve

pag. 62

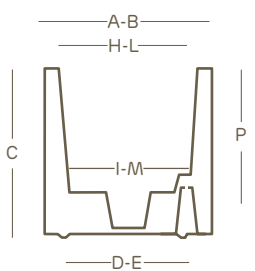

Art. 2853
 cm. 18

A-B cm. 18
 C cm. 18
 D-E cm. 14
 H-L cm. 15
 I-M cm. 13
 P cm. 14

mini kube cassetta • plant box

pag. 58

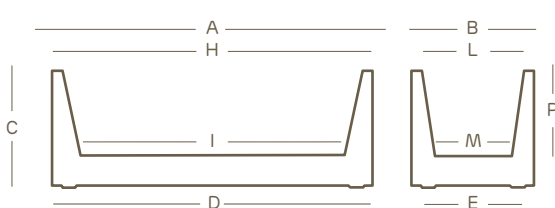

Art. 2828
 cm. 50

Art. 2776
 cm. 60

A	cm. 50	A	cm. 60
B	cm. 18	B	cm. 20
C	cm. 18	C	cm. 20
D	cm. 46	D	cm. 55
E	cm. 14	E	cm. 14,5
H	cm. 47	H	cm. 55
I	cm. 40,5	I	cm. 52
L	cm. 15	L	cm. 15
M	cm. 13	M	cm. 13
P	cm. 14	P	cm. 15,5

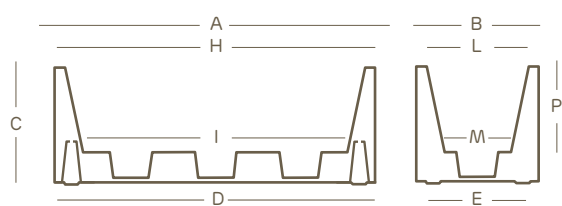

Art. 2852
cm. 50

- A cm. 50
- B cm. 18
- C cm. 18
- D cm. 46
- E cm. 14
- H cm. 47
- I cm. 40,5
- L cm. 15
- M cm. 13
- P cm. 14

khilia gloss

dati tecnici

technical data

ilie gloss

pag. 66

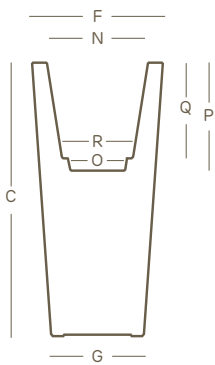

Art. 2579	Art. 2509	Art. 2518	Art. 2580
ø cm. 32	ø cm. 37	ø cm. 47	ø cm. 57
C cm. 67	C cm. 75	C cm. 98	C cm. 126
F cm. 32	F cm. 37	F cm. 47	F cm. 57
G cm. 23	G cm. 26	G cm. 33	G cm. 40
N cm. 24	N cm. 28	N cm. 36	N cm. 44
O cm. 15	O cm. 15	O cm. 20	O cm. 28
P cm. 29	P cm. 33	P cm. 41	P cm. 50
Q cm. 23	Q cm. 27	Q cm. 35	Q cm. 44
R cm. 18	R cm. 20	R cm. 25	R cm. 32

kiam gloss

pag. 67

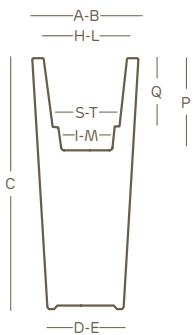

Art. 2637	Art. 2581	Art. 2638	Art. 2582
cm. 25	cm. 30	cm. 35	cm. 40
A-B cm. 25	A-B cm. 30	A-B cm. 35	A-B cm. 40
C cm. 56	C cm. 67	C cm. 75	C cm. 90
D-E cm. 18	D-E cm. 21	D-E cm. 26	D-E cm. 28
H-L cm. 18	H-L cm. 22	H-L cm. 26	H-L cm. 30
I-M cm. 13	I-M cm. 14	I-M cm. 14	I-M cm. 21
P cm. 17	P cm. 26	P cm. 31	P cm. 33
Q cm. 13	Q cm. 19	Q cm. 24	Q cm. 27
S-T cm. 15	S-T cm. 17	S-T cm. 17	S-T cm. 24

kube gloss vaso • pot

pag. 68

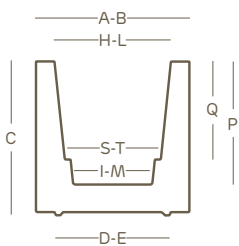

Art. 2583	Art. 2584	Art. 2585
cm. 30	cm. 40	cm. 50
A-B cm. 30	A-B cm. 40	A-B cm. 50
C cm. 30	C cm. 40	C cm. 50
D-E cm. 22	D-E cm. 29	D-E cm. 37
H-L cm. 23	H-L cm. 30	H-L cm. 38
I-M cm. 14	I-M cm. 19	I-M cm. 25
P cm. 25	P cm. 33	P cm. 41
Q cm. 18	Q cm. 27	Q cm. 35
S-T cm. 17	S-T cm. 24	S-T cm. 30

kuno gloss

pag. 69

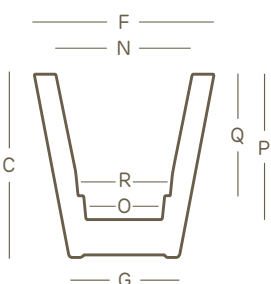

Art. 2536	Art. 2534	Art. 2535
ø cm. 40	ø cm. 50	ø cm. 60
C cm. 40	C cm. 50	C cm. 60
F cm. 40	F cm. 50	F cm. 60
G cm. 24	G cm. 30	G cm. 37
N cm. 30	N cm. 38	N cm. 46
O cm. 17	O cm. 21	O cm. 28
P cm. 32	P cm. 40	P cm. 48
Q cm. 26	Q cm. 36	Q cm. 42
R cm. 20	R cm. 25	R cm. 32

khilia laccati

dati tecnici

technical data

ikon laccato • lacquered

pag. 72

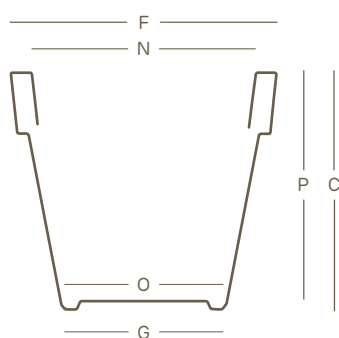

Art. L2603	Art. L2604	Art. L2605	Art. L2896	Art. L2541	Art. L2542	Art. L2543
ø cm. 40	ø cm. 50	ø cm. 60	ø cm. 70	ø cm. 80	ø cm. 100	ø cm. 120
C cm. 36	C cm. 44	C cm. 53	C cm. 62	C cm. 71	C cm. 89	C cm. 107
F cm. 40	F cm. 50	F cm. 60	F cm. 70	F cm. 80	F cm. 100	F cm. 120
G cm. 23	G cm. 29	G cm. 35	G cm. 42	G cm. 47	G cm. 59	G cm. 72
N cm. 34	N cm. 43	N cm. 52	N cm. 60	N cm. 69	N cm. 86	N cm. 103
O cm. 25	O cm. 30	O cm. 36	O cm. 41	O cm. 50	O cm. 61	O cm. 72
P cm. 33	P cm. 42	P cm. 51	P cm. 59	P cm. 70	P cm. 88	P cm. 106

quadrum laccato • lacquered

pag. 74

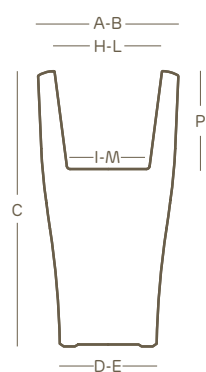

Art. L2419	Art. L2420
cm. 37	cm. 51
A-B cm. 37	A-B cm. 51
C cm. 73	C cm. 100
D-E cm. 26	D-E cm. 35
H-L cm. 29	H-L cm. 39
I-M cm. 22	I-M cm. 30
P cm. 27	P cm. 35

Legenda / Legend



Lampada fluorescente MAX 1 x 60 W
Fluorescent lamp MAX 1 x 60 W



Classe di isolamento: Classe II.
Con doppio isolamento e/o rinforzo in ogni parte e senza dispositivi per la messa a terra.
Insulation class: Class II.
With double insulation and/or reinforcement in each part and without ground devices.



Classe di isolamento: Classe III
Con isolamento ridotto perchè destinato a essere esclusivamente alimentato da un sistema a bassissima tensione di sicurezza (minore o uguale a 48V dc) e nel quale si generano tensioni di valore superiore a quello di tale sistema.
Insulation class: Class III.
With reduced insulation because the device is destined to be powered exclusively by a safety extra-low voltage system (max. 48V DC or less) in which voltages of values higher than those of such system are generated.



Attesta la conformità del prodotto alle disposizioni delle direttive comunitarie.
It certifies the conformity of the product to the European community instructions.

IP 20

Prodotto di uso ordinario. Protetto contro corpi solidi di diametro superiore a 12,5mm. L'utente non ha comunque modo di entrare in contatto con le parti in tensione. Prodotto con nessuna protezione nei confronti della penetrazione dell'acqua.
Product for ordinary use, protected against solid objects larger than 12.5 mm in diameter. Users cannot however come into contact with the live parts. This product has no water protection.

IP 67

Totalmente protetto contro la penetrazione di polveri. Prodotto resistente all'immersione temporanea massimo ad 1m di profondità. L'icona, dove presente, fa riferimento al corpo lampada.
Totally protected against penetration of dust. Product resistant against temporary immersion in water to a maximum of 1 m depth. Wherever present, the icon refers to the lamp's casing.

IP 68

Totalmente protetto contro la penetrazione di polveri. Prodotto resistente alla sommersione permanente in acqua. L'icona, dove presente, fa riferimento al corpo lampada.
Totally protected against penetration of dust. Product resistant against permanent immersion in water. Wherever present, the icon refers to the lamp's casing.



Ai sensi della Direttiva 2012/19/UE, il prodotto, alla fine della sua vita utile, non deve essere smaltito come rifiuto urbano.
According to the Directive 2012/19/UE, once the device life time is ended, it must not be disposed as urban waste.

Tutte le apparecchiature elettriche sono conformi alle direttive 2011/65/UE sulle Restrizioni d'uso di alcune sostanze pericolose (RoHS), recepite in Italia con il D.lgs 04/03/2014 n.27.

All electric equipments meet the Directives 2011/65/UE about the Reduction of the use of certain Hazardous Substances (RoHS), which came into force in Italy with D. lgs 04/03/2014 n.27.

Avvertenze - Warning:

- Collegare la spina dell'apparecchio in una presa collocata in un luogo protetto dalla pioggia e dagli spruzzi d'acqua.
- Se il cavo flessibile esterno di questo apparecchio viene danneggiato, deve essere sostituito esclusivamente dal costruttore, dal suo servizio di assistenza, o da personale qualificato equivalente, al fine di evitare pericoli.
- Nelle versioni sprovviste di interruttore sul cavo di alimentazione, collegare la spina dell'apparecchio sotto una presa comandata da interruttore.
- Si sconsiglia l'utilizzo e/o l'installazione dei prodotti luminosi su superfici/pavimentazioni non solide (sabbia, terra, erba, sassi, ghiaia, ecc.).
Inoltre, i prodotti luminosi non dovranno essere installati in prossimità (adiacenti e sullo stesso piano) di piscine e/o ambienti d'acqua.

- Connect the plug of the appliance to a power outlet that is located in a sheltered position, protected from rain and water splashes.
- If the external flexible cable of this appliance is damaged it must be replaced by either the manufacturer, the manufacturer's customer assistance service or by equivalent qualified personnel, in order to prevent possible hazards.
- For models that are not equipped with an inline on/off switch, connect the plug of the appliance to a switch controlled outlet.
- The use and/or installation of illumination devices on instable surfaces/floors or pavement (sand, soil, grass, stones, gravel, etc.) is discouraged. Neither must illumination devices be installed near (adjacent to or on the same level as) swimming pools and/or other water environments

khilia lights

dati tecnici

technical data

ikon light indoor

pag. 90

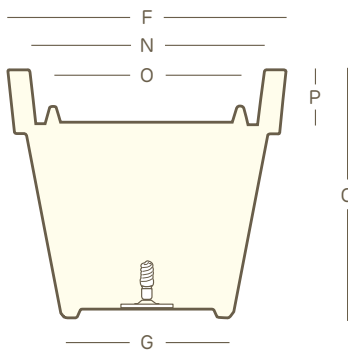

Art. 2721	Art. 2725	Art. 2729	Art. 2899	Art. 2641
ø cm. 40	ø cm. 50	ø cm. 60	ø cm. 70	ø cm. 80
C cm. 36	C cm. 44	C cm. 53	C cm. 62	C cm. 71
F cm. 40	F cm. 50	F cm. 60	F cm. 70	F cm. 80
G cm. 23	G cm. 29	G cm. 35	G cm. 42	G cm. 47
N cm. 34	N cm. 43	N cm. 52	N cm. 60	N cm. 69
O cm. 25	O cm. 30	O cm. 37	O cm. 44	O cm. 50
P cm. 6,7	P cm. 8,4	P cm. 10	P cm. 12	P cm. 13

ikon light indoor

pag. 90

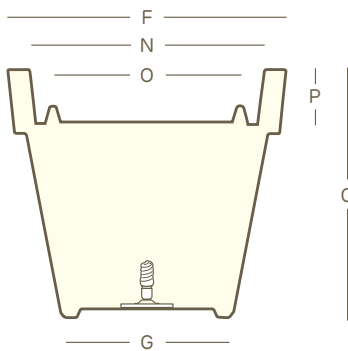

Art. 2653	Art. 2657	Art. 2806	Art. 2810
ø cm. 100	ø cm. 120	ø cm. 140	ø cm. 160
C cm. 89	C cm. 107	C cm. 125	C cm. 143
F cm. 100	F cm. 120	F cm. 140	F cm. 160
G cm. 59	G cm. 72	G cm. 85	G cm. 97
N cm. 86	N cm. 103	N cm. 120	N cm. 138
O cm. 62	O cm. 75	O cm. 87	O cm. 100
P cm. 18	P cm. 22	P cm. 29	P cm. 33

ikon light outdoor

pag. 90

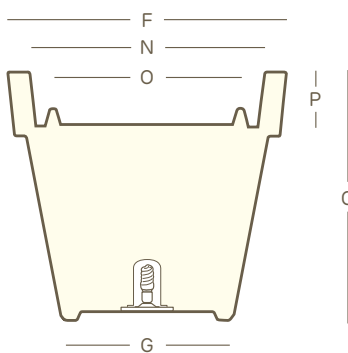

Art. 2722	Art. 2726	Art. 2730	Art. 2900	Art. 2642
ø cm. 40	ø cm. 50	ø cm. 60	ø cm. 70	ø cm. 80
C cm. 36	C cm. 44	C cm. 53	C cm. 62	C cm. 71
F cm. 40	F cm. 50	F cm. 60	F cm. 70	F cm. 80
G cm. 23	G cm. 29	G cm. 35	G cm. 42	G cm. 47
N cm. 34	N cm. 43	N cm. 52	N cm. 60	N cm. 69
O cm. 25	O cm. 30	O cm. 37	O cm. 44	O cm. 50
P cm. 6,7	P cm. 8,4	P cm. 10	P cm. 12	P cm. 13

ikon light outdoor

pag. 90 - 91

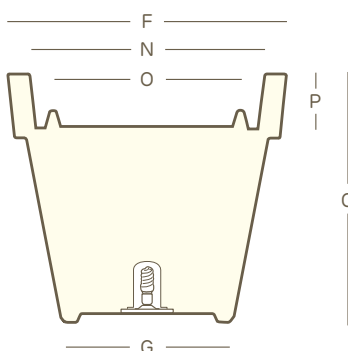

Art. 2654	Art. 2658	Art. 2807	Art. 2811	Art. 2999
ø cm. 100	ø cm. 120	ø cm. 140	ø cm. 160	ø cm. 200
C cm. 89	C cm. 107	C cm. 125	C cm. 143	C cm. 178
F cm. 100	F cm. 120	F cm. 140	F cm. 160	F cm. 200
G cm. 59	G cm. 72	G cm. 85	G cm. 97	G cm. 120
N cm. 86	N cm. 103	N cm. 120	N cm. 138	N cm. 172
O cm. 62	O cm. 75	O cm. 87	O cm. 100	O cm. 124
P cm. 18	P cm. 22	P cm. 29	P cm. 33	P cm. 40

ikon rgb led light indoor

pag. 90

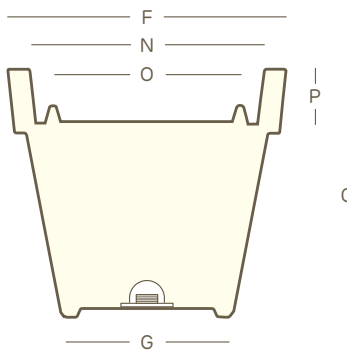

Art. 2723 ø cm. 40	Art. 2727 ø cm. 50	Art. 2731 ø cm. 60	Art. 2901 ø cm. 70	Art. 2643 ø cm. 80
C cm. 36	C cm. 44	C cm. 53	C cm. 62	C cm. 71
F cm. 40	F cm. 50	F cm. 60	F cm. 70	F cm. 80
G cm. 23	G cm. 29	G cm. 35	G cm. 42	G cm. 47
N cm. 34	N cm. 43	N cm. 52	N cm. 60	N cm. 69
O cm. 25	O cm. 30	O cm. 37	O cm. 44	O cm. 50
P cm. 6,7	P cm. 8,4	P cm. 10	P cm. 12	P cm. 13

ikon rgb led light indoor

pag. 90

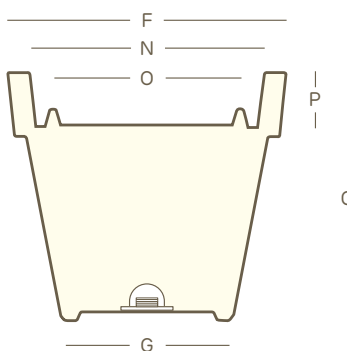

Art. 2655 ø cm. 100	Art. 2659 ø cm. 120	Art. 2808 ø cm. 140	Art. 2812 ø cm. 160
C cm. 89	C cm. 107	C cm. 125	C cm. 143
F cm. 100	F cm. 120	F cm. 140	F cm. 160
G cm. 59	G cm. 72	G cm. 85	G cm. 97
N cm. 86	N cm. 103	N cm. 120	N cm. 138
O cm. 62	O cm. 75	O cm. 87	O cm. 100
P cm. 18	P cm. 22	P cm. 29	P cm. 33

ikon rgb led light outdoor

pag. 90

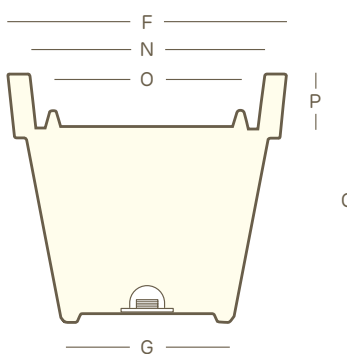

Art. 2724 ø cm. 40	Art. 2728 ø cm. 50	Art. 2732 ø cm. 60	Art. 2902 ø cm. 70	Art. 2644 ø cm. 80
C cm. 36	C cm. 44	C cm. 53	C cm. 62	C cm. 71
F cm. 40	F cm. 50	F cm. 60	F cm. 70	F cm. 80
G cm. 23	G cm. 29	G cm. 35	G cm. 42	G cm. 47
N cm. 34	N cm. 43	N cm. 52	N cm. 60	N cm. 69
O cm. 25	O cm. 30	O cm. 37	O cm. 44	O cm. 50
P cm. 6,7	P cm. 8,4	P cm. 10	P cm. 12	P cm. 13

ikon rgb led light outdoor

pag. 90 - 91

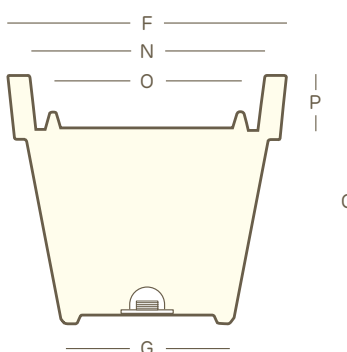

Art. 2656 ø cm. 100	Art. 2660 ø cm. 120	Art. 2809 ø cm. 140	Art. 2813 ø cm. 160	Art. 3001 ø cm. 200
C cm. 89	C cm. 107	C cm. 125	C cm. 143	C cm. 178
F cm. 100	F cm. 120	F cm. 140	F cm. 160	F cm. 200
G cm. 59	G cm. 72	G cm. 85	G cm. 97	G cm. 120
N cm. 86	N cm. 103	N cm. 120	N cm. 138	N cm. 172
O cm. 62	O cm. 75	O cm. 87	O cm. 100	O cm. 124
P cm. 18	P cm. 22	P cm. 29	P cm. 33	P cm. 40

ikon light outdoor

pag. 91

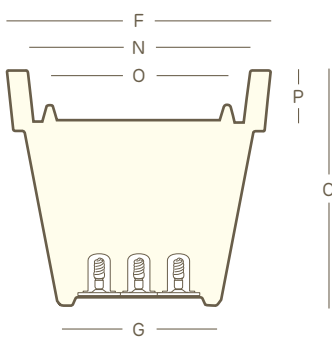

Art. 3015
ø cm. 200

C cm. 178
F cm. 200
G cm. 120
N cm. 172
O cm. 124
P cm. 40

ikon rgb led light outdoor

pag. 91

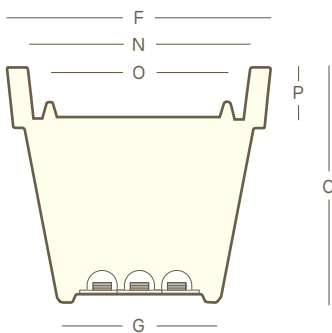

Art. 3016
ø cm. 200

C cm. 178
F cm. 200
G cm. 120
N cm. 172
O cm. 124
P cm. 40

ilie light indoor

pag. 85

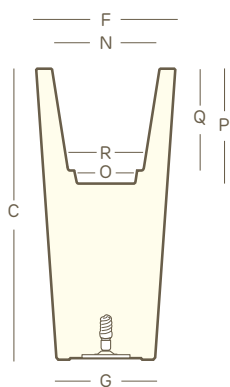

Art. 2661
ø cm. 37

Art. 2665
ø cm. 42

Art. 2669
ø cm. 47

Art. 2673
ø cm. 57

C cm. 75	C cm. 90	C cm. 98	C cm. 126
F cm. 37	F cm. 42	F cm. 47	F cm. 57
G cm. 26	G cm. 29	G cm. 33	G cm. 40
N cm. 28	N cm. 33	N cm. 36	N cm. 44
O cm. 15	O cm. 24	O cm. 20	O cm. 28
P cm. 33	P cm. 31	P cm. 41	P cm. 50
Q cm. 27		Q cm. 35	Q cm. 44
R cm. 20		R cm. 25	R cm. 32

ilie light outdoor

pag. 85

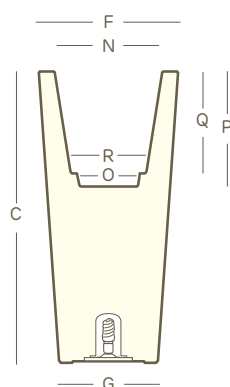

Art. 2662
ø cm. 37

Art. 2666
ø cm. 42

Art. 2670
ø cm. 47

Art. 2674
ø cm. 57

C cm. 75	C cm. 90	C cm. 98	C cm. 126
F cm. 37	F cm. 42	F cm. 47	F cm. 57
G cm. 26	G cm. 29	G cm. 33	G cm. 40
N cm. 28	N cm. 33	N cm. 36	N cm. 44
O cm. 15	O cm. 24	O cm. 20	O cm. 28
P cm. 33	P cm. 31	P cm. 41	P cm. 50
Q cm. 27		Q cm. 35	Q cm. 44
R cm. 20		R cm. 25	R cm. 32

ilie rgb led light indoor

pag. 85

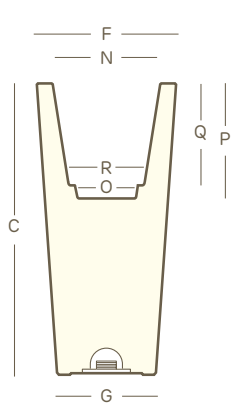

Art. 2663	Art. 2667	Art. 2671	Art. 2675
ø cm. 37	ø cm. 42	ø cm. 47	ø cm. 57
C cm. 75	C cm. 90	C cm. 98	C cm. 126
F cm. 37	F cm. 42	F cm. 47	F cm. 57
G cm. 26	G cm. 29	G cm. 33	G cm. 40
N cm. 28	N cm. 33	N cm. 36	N cm. 44
O cm. 15	O cm. 24	O cm. 20	O cm. 28
P cm. 33	P cm. 31	P cm. 41	P cm. 50
Q cm. 27		Q cm. 35	Q cm. 44
R cm. 20		R cm. 25	R cm. 32

ilie rgb led light outdoor

pag. 85

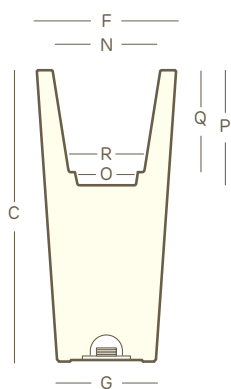

Art. 2664	Art. 2668	Art. 2672	Art. 2676
ø cm. 37	ø cm. 42	ø cm. 47	ø cm. 57
C cm. 75	C cm. 90	C cm. 98	C cm. 126
F cm. 37	F cm. 42	F cm. 47	F cm. 57
G cm. 26	G cm. 29	G cm. 33	G cm. 40
N cm. 28	N cm. 33	N cm. 36	N cm. 44
O cm. 15	O cm. 24	O cm. 20	O cm. 28
P cm. 33	P cm. 31	P cm. 41	P cm. 50
Q cm. 27		Q cm. 35	Q cm. 44
R cm. 20		R cm. 25	R cm. 32

kiam light indoor

pag. 84

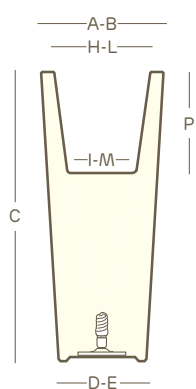

Art. 2693	Art. 2697
cm. 35	cm. 40
A-B cm. 35	A-B cm. 40
C cm. 75	C cm. 90
D-E cm. 25	D-E cm. 28
H-L cm. 26	H-L cm. 30
I-M cm. 20	I-M cm. 23
P cm. 24	P cm. 28

kiam light outdoor

pag. 84

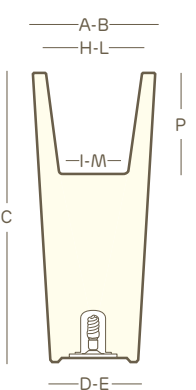

Art. 2694	Art. 2698
cm. 35	cm. 40
A-B cm. 35	A-B cm. 40
C cm. 75	C cm. 90
D-E cm. 25	D-E cm. 28
H-L cm. 26	H-L cm. 30
I-M cm. 20	I-M cm. 23
P cm. 24	P cm. 28

kiam rgb led light indoor

pag. 84

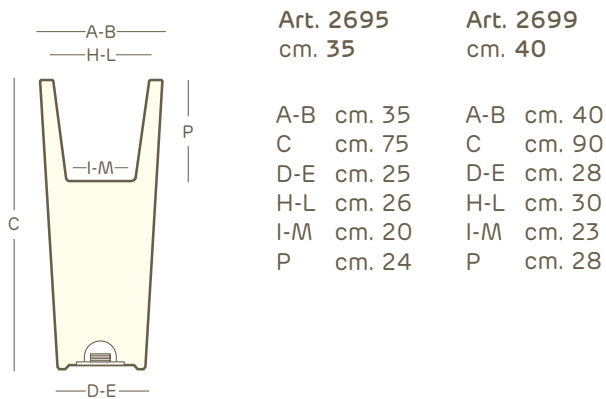

kiam rgb led light outdoor

pag. 84

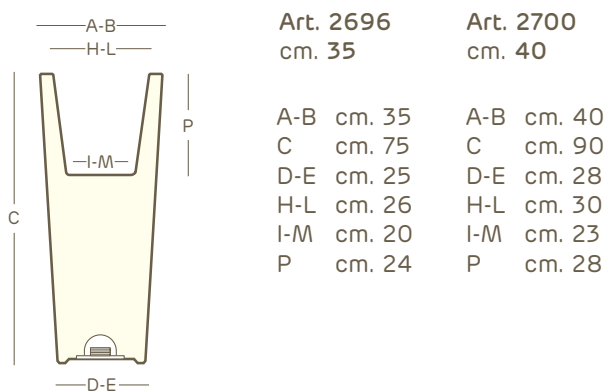

kube light indoor sgabello • stool

pag. 78

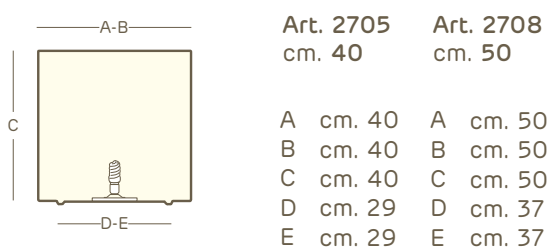

kube light outdoor sgabello • stool

pag. 78

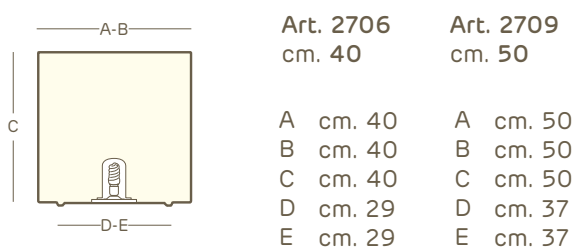

kube rgb led light indoor sgabello • stool

pag. 78

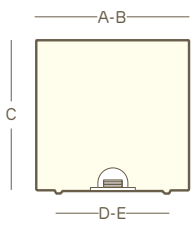

Art. 2707
cm. 40

Art. 2710
cm. 50

A cm. 40
B cm. 40
C cm. 40
D cm. 29
E cm. 29

A cm. 50
B cm. 50
C cm. 50
D cm. 37
E cm. 37

kube rgb led light outdoor sgabello • stool

pag. 78

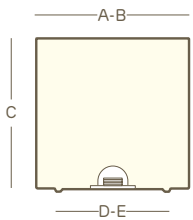

Art. 2707
cm. 40

Art. 2710
cm. 50

A cm. 40
B cm. 40
C cm. 40
D cm. 29
E cm. 29

A cm. 50
B cm. 50
C cm. 50
D cm. 37
E cm. 37

kube light indoor panca • bench

pag. 79

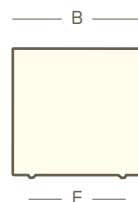
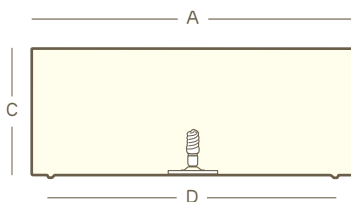

Art. 2755
cm. 100

A cm. 100
B cm. 40
C cm. 40
D cm. 90
E cm. 29

kube light outdoor panca • bench

pag. 79

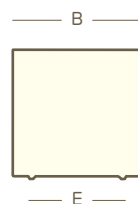
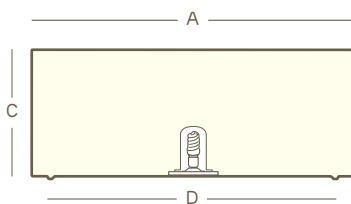

Art. 2756
cm. 100

A cm. 100
B cm. 40
C cm. 40
D cm. 90
E cm. 29

kube rgb led light indoor panca • bench

pag. 79

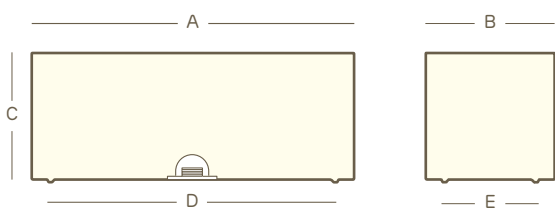

Art. 2757
cm. 100

A cm. 100
B cm. 40
C cm. 40
D cm. 90
E cm. 29

kube rgb led light outdoor panca • bench

pag. 79

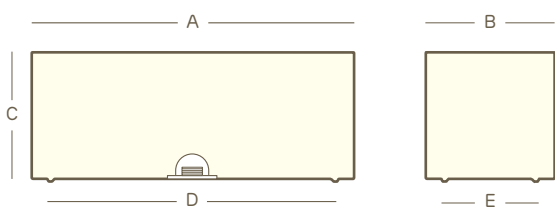

Art. 2757
cm. 100

A cm. 100
B cm. 40
C cm. 40
D cm. 90
E cm. 29

kube high light indoor cassetta alta • high plant box

pag. 81

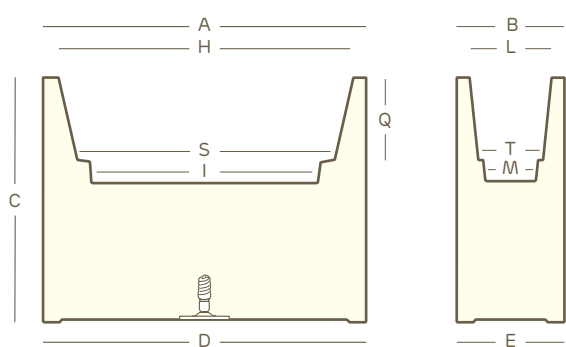

Art. 2745
cm. 80

Art. 2701
cm. 100

A cm. 80	L cm. 22	A cm. 100	L cm. 30
B cm. 30	M cm. 14	B cm. 40	M cm. 19
C cm. 70	P cm. 25	C cm. 70	P cm. 34
D cm. 80	Q cm. 19	D cm. 100	Q cm. 30
E cm. 30	S cm. 51	E cm. 40	S cm. 72
H cm. 73	T cm. 17	H cm. 90	T cm. 24
I cm. 49		I cm. 70	

kube high light outdoor cassetta alta • high plant box

pag. 81

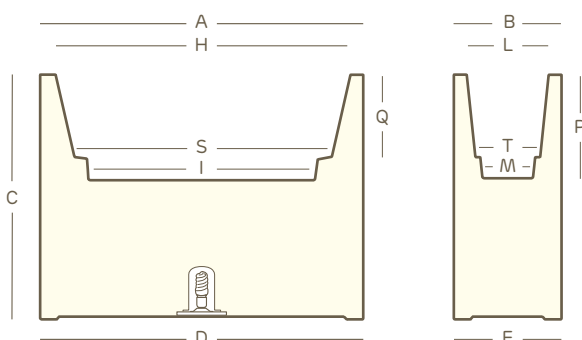

Art. 2746
cm. 80

Art. 2702
cm. 100

A cm. 80	L cm. 22	A cm. 100	L cm. 30
B cm. 30	M cm. 14	B cm. 40	M cm. 19
C cm. 70	P cm. 25	C cm. 70	P cm. 34
D cm. 80	Q cm. 19	D cm. 100	Q cm. 30
E cm. 30	S cm. 51	E cm. 40	S cm. 72
H cm. 73	T cm. 17	H cm. 90	T cm. 24
I cm. 49		I cm. 70	

kube high rgb led light indoor cassetta alta • high plant box

pag. 81

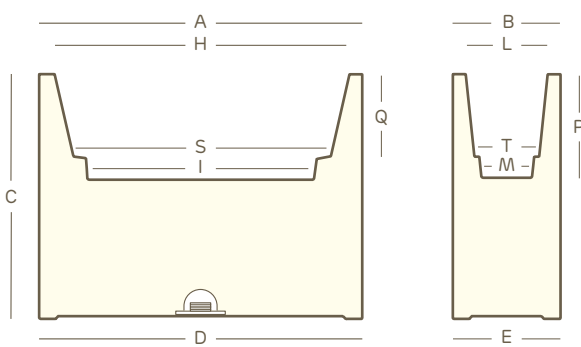

Art. 2747
cm. 80

Art. 2703
cm. 100

A cm. 80	L cm. 22	A cm. 100	L cm. 30
B cm. 30	M cm. 14	B cm. 40	M cm. 19
C cm. 70	P cm. 25	C cm. 70	P cm. 34
D cm. 80	Q cm. 19	D cm. 100	Q cm. 30
E cm. 30	S cm. 51	E cm. 40	S cm. 72
H cm. 73	T cm. 17	H cm. 90	T cm. 24
I cm. 49		I cm. 70	

kube high rgb led light outdoor cassetta alta • high plant box

pag. 81

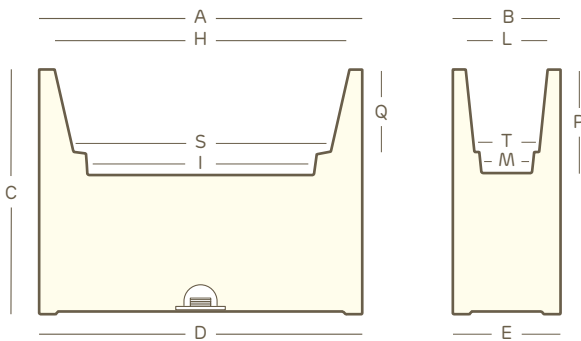

Art. 2748
cm. 80

Art. 2704
cm. 100

A cm. 80	L cm. 22	A cm. 100	L cm. 30
B cm. 30	M cm. 14	B cm. 40	M cm. 19
C cm. 70	P cm. 25	C cm. 70	P cm. 34
D cm. 80	Q cm. 19	D cm. 100	Q cm. 30
E cm. 30	S cm. 51	E cm. 40	S cm. 72
H cm. 73	T cm. 17	H cm. 90	T cm. 24
I cm. 49		I cm. 70	

kube high light indoor vaso alto • high pot

pag. 80

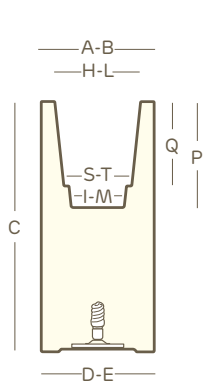

Art. 2737
cm. 30

Art. 2741
cm. 40

A-B cm. 30	A-B cm. 40
C cm. 70	C cm. 70
D-E cm. 29	D-E cm. 39
H-L cm. 23	H-L cm. 30
I-M cm. 14	I-M cm. 19
P cm. 25	P cm. 33
Q cm. 18	Q cm. 26
S-T cm. 17	S-T cm. 24

kube high light outdoor vaso alto • high pot

pag. 80

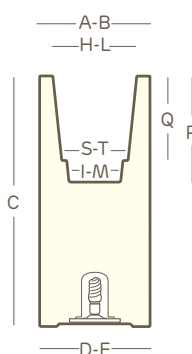

Art. 2738
cm. 30

Art. 2742
cm. 40

A-B cm. 30	A-B cm. 40
C cm. 70	C cm. 70
D-E cm. 29	D-E cm. 39
H-L cm. 23	H-L cm. 30
I-M cm. 14	I-M cm. 19
P cm. 25	P cm. 33
Q cm. 18	Q cm. 26
S-T cm. 17	S-T cm. 24

kube high rgb led light indoor vaso alto • high pot

pag. 80

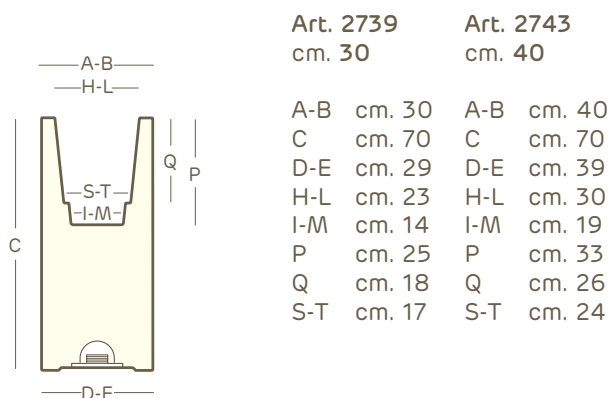

kube high rgb led light outdoor vaso alto • high pot

pag. 80

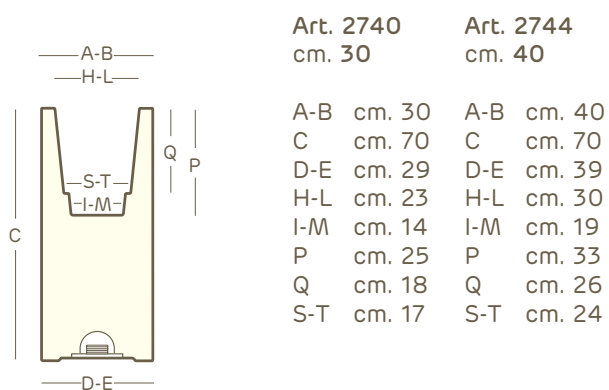

kube high slim light indoor cassetta alta • high plant box

pag. 93

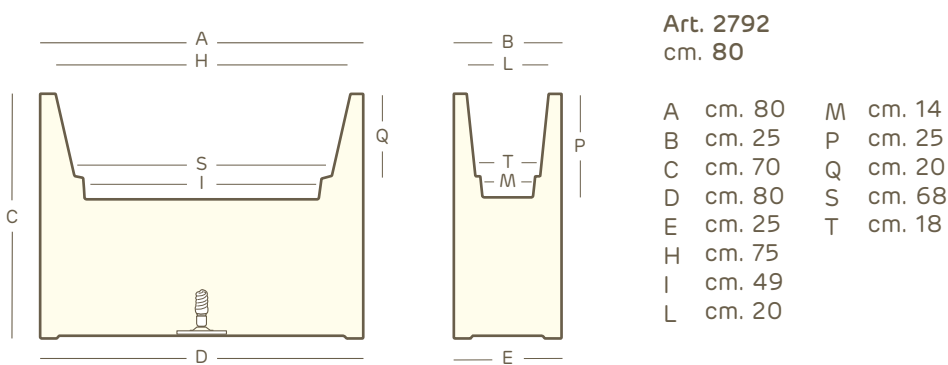

kube high slim light outdoor cassetta alta • high plant box

pag. 93

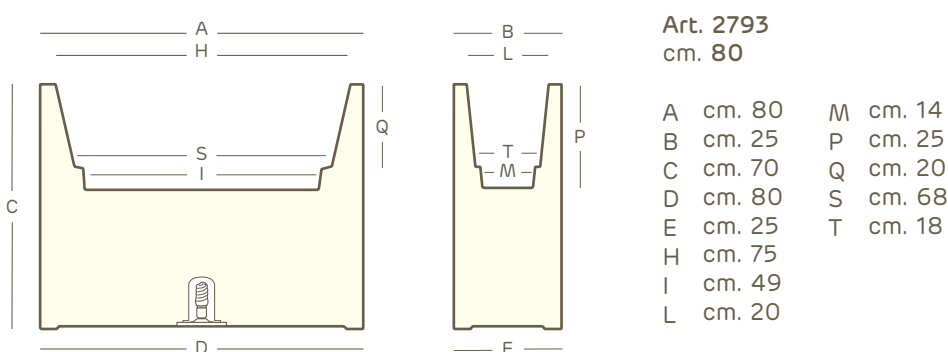

kube high slim rgb led light indoor cassetta alta • high plant box

pag. 93

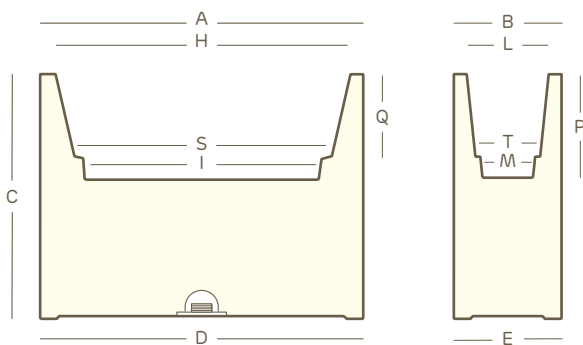

Art. 2794
cm. 80

A	cm. 80	M	cm. 14
B	cm. 25	P	cm. 25
C	cm. 70	Q	cm. 20
D	cm. 80	S	cm. 68
E	cm. 25	T	cm. 18
H	cm. 75		
I	cm. 49		
L	cm. 20		

kube high slim rgb led light outdoor cassetta alta • high plant box

pag. 93

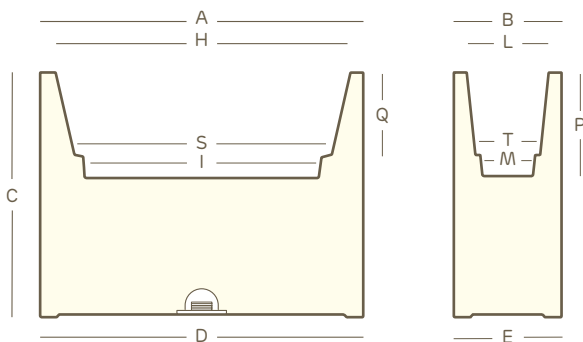

Art. 2795
cm. 80

A	cm. 80	M	cm. 14
B	cm. 25	P	cm. 25
C	cm. 70	Q	cm. 20
D	cm. 80	S	cm. 68
E	cm. 25	T	cm. 18
H	cm. 75		
I	cm. 49		
L	cm. 20		

kube high slim light indoor vaso alto • high pot

pag. 92

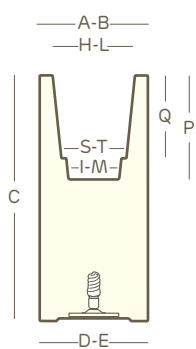

Art. 2796
cm. 25

A-B	cm. 25
C	cm. 70
D-E	cm. 25
H-L	cm. 20
I-M	cm. 15
P	cm. 26,5
Q	cm. 20
S-T	cm. 18

kube high slim light outdoor vaso alto • high pot

pag. 92

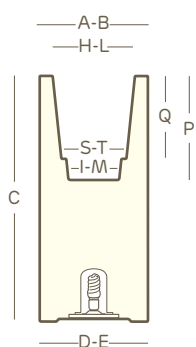

Art. 2797
cm. 25

A-B	cm. 25
C	cm. 70
D-E	cm. 25
H-L	cm. 20
I-M	cm. 15
P	cm. 26,5
Q	cm. 20
S-T	cm. 18

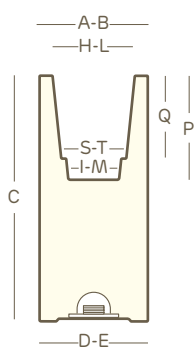

Art. 2798
cm. 25

A-B	cm. 25
C	cm. 70
D-E	cm. 25
H-L	cm. 20
I-M	cm. 15
P	cm. 26,5
Q	cm. 20
S-T	cm. 18

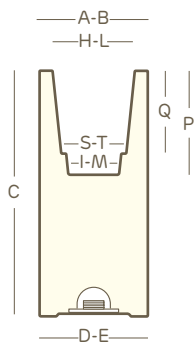

Art. 2799
cm. 25

A-B	cm. 25
C	cm. 70
D-E	cm. 25
H-L	cm. 20
I-M	cm. 15
P	cm. 26,5
Q	cm. 20
S-T	cm. 18

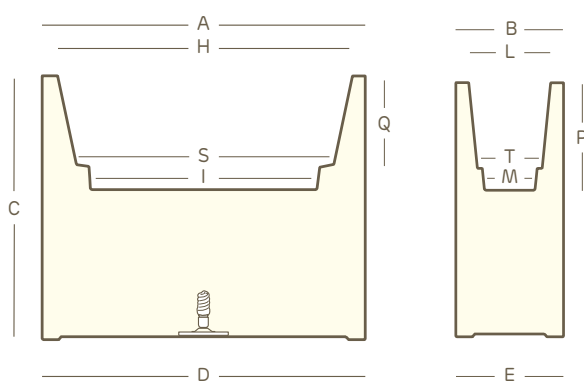

Art. 2835
cm. 70

A	cm. 70	L	cm. 23
B	cm. 30	M	cm. 14
C	cm. 90	P	cm. 26,5
D	cm. 70	Q	cm. 20
E	cm. 30	S	cm. 53
H	cm. 63	T	cm. 20
I	cm. 49,5		

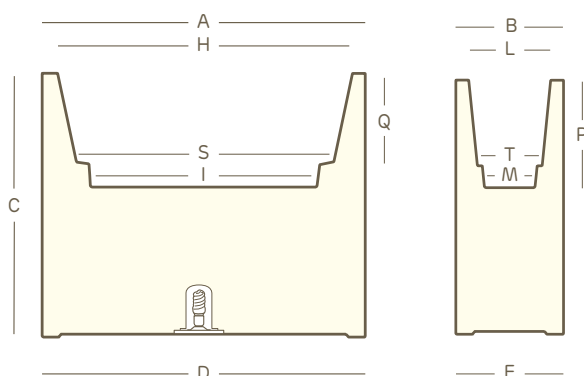

Art. 2836
cm. 70

A	cm. 70	L	cm. 23
B	cm. 30	M	cm. 14
C	cm. 90	P	cm. 26,5
D	cm. 70	Q	cm. 20
E	cm. 30	S	cm. 53
H	cm. 63	T	cm. 20
I	cm. 49,5		

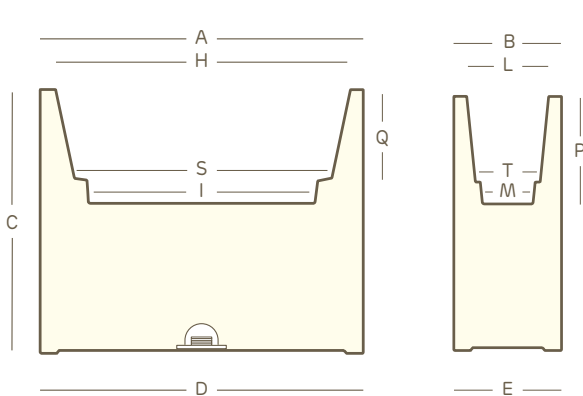

Art. 2837
cm. 70

A	cm. 70	L	cm. 23
B	cm. 30	M	cm. 14
C	cm. 90	P	cm. 26,5
D	cm. 70	Q	cm. 20
E	cm. 30	S	cm. 53
H	cm. 63	T	cm. 20
I	cm. 49,5		

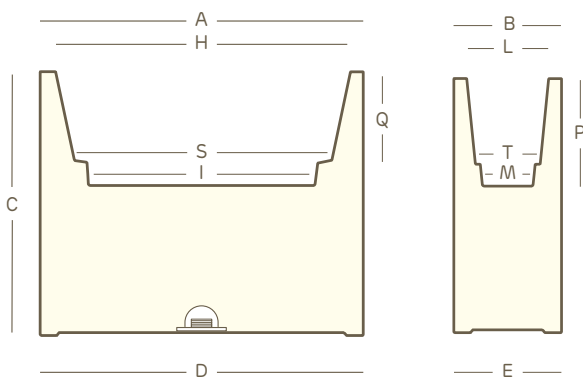

Art. 2838
cm. 70

A	cm. 70	L	cm. 23
B	cm. 30	M	cm. 14
C	cm. 90	P	cm. 26,5
D	cm. 70	Q	cm. 20
E	cm. 30	S	cm. 53
H	cm. 63	T	cm. 20
I	cm. 49,5		

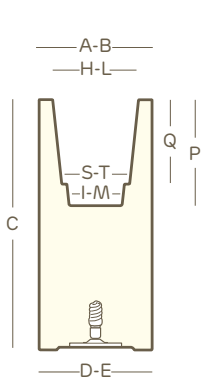

Art. 2831
cm. 30

A-B	cm. 30
C	cm. 90
D-E	cm. 30
H-L	cm. 23
I-M	cm. 14
P	cm. 26,5
Q	cm. 20
S-T	cm. 18

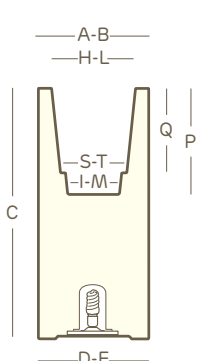

Art. 2832
cm. 30

A-B	cm. 30
C	cm. 90
D-E	cm. 30
H-L	cm. 23
I-M	cm. 14
P	cm. 26,5
Q	cm. 20
S-T	cm. 18

kube tower rgb led light indoor vaso alto • high pot

pag. 94

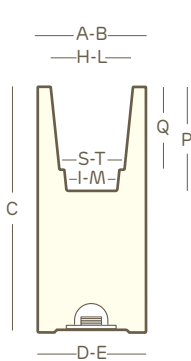

Art. 2833
cm. 30

A-B	cm. 30
C	cm. 90
D-E	cm. 30
H-L	cm. 23
I-M	cm. 14
P	cm. 26,5
Q	cm. 20
S-T	cm. 18

kube tower rgb led light outdoor vaso alto • high pot

pag. 94

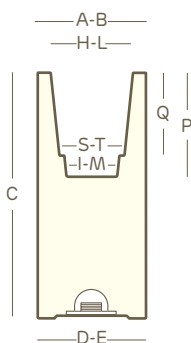

Art. 2834
cm. 30

A-B	cm. 30
C	cm. 90
D-E	cm. 30
H-L	cm. 23
I-M	cm. 14
P	cm. 26,5
Q	cm. 20
S-T	cm. 18

quadrum light indoor

pag. 82

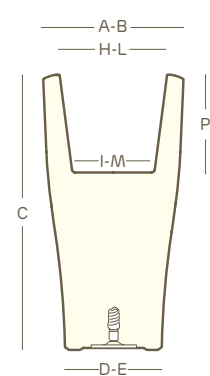

Art. 2711
cm. 51

A-B	cm. 51
C	cm. 100
D-E	cm. 35
H-L	cm. 39
I-M	cm. 30
P	cm. 35

quadrum light outdoor

pag. 82

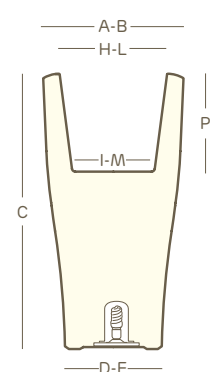

Art. 2712
cm. 51

A-B	cm. 51
C	cm. 100
D-E	cm. 35
H-L	cm. 39
I-M	cm. 30
P	cm. 35

quadrum rgb led light indoor

pag. 82

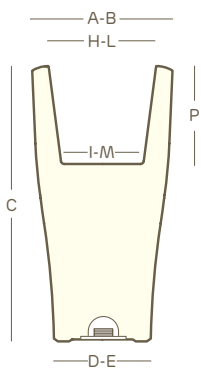

Art. 2713
cm. 51

A-B cm. 51
C cm. 100
D-E cm. 35
H-L cm. 39
I-M cm. 30
P cm. 35

quadrum rgb led light outdoor

pag. 82

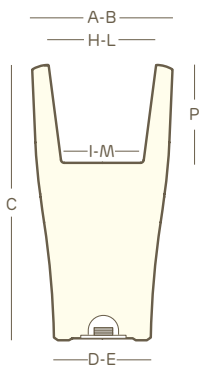

Art. 2714
cm. 51

A-B cm. 51
C cm. 100
D-E cm. 35
H-L cm. 39
I-M cm. 30
P cm. 35

sfera light indoor

pag. 86

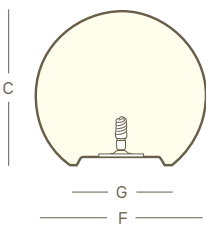

Art. 2639	Art. 2715	Art. 2718
ø cm. 45	ø cm. 55	ø cm. 65

C cm. 40	C cm. 50	C cm. 60
F cm. 45	F cm. 55	F cm. 65
G cm. 28	G cm. 31	G cm. 34

sfera light outdoor

pag. 86

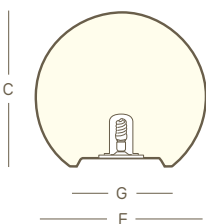

Art. 2651	Art. 2716	Art. 2719
ø cm. 45	ø cm. 55	ø cm. 65

C cm. 40	C cm. 50	C cm. 60
F cm. 45	F cm. 55	F cm. 65
G cm. 28	G cm. 31	G cm. 34

sfera rgb led light indoor

pag. 86

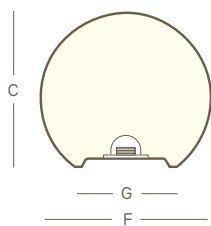

Art. 2749	Art. 2717	Art. 2720
ø cm. 45	ø cm. 55	ø cm. 65
C cm. 40	C cm. 50	C cm. 60
F cm. 45	F cm. 55	F cm. 65
G cm. 28	G cm. 31	G cm. 34

sfera rgb led light outdoor

pag. 86

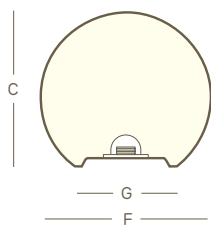

Art. 2749	Art. 2717	Art. 2720
ø cm. 45	ø cm. 55	ø cm. 65
C cm. 40	C cm. 50	C cm. 60
F cm. 45	F cm. 55	F cm. 65
G cm. 28	G cm. 31	G cm. 34

sfera con piedistallo light indoor

pag. 88

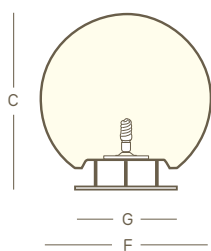

Art. 2759
ø cm. 65
C cm. 70
F cm. 65
G cm. 34

sfera con piedistallo light outdoor

pag. 88

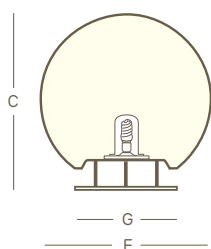

Art. 2760
ø cm. 65
C cm. 70
F cm. 65
G cm. 34

sfera con piedistallo rgb led light indoor

pag. 88

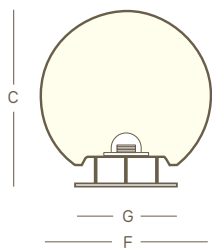

Art. 2761
ø cm. 65

C cm. 70
F cm. 65
G cm. 34

sfera con piedistallo rgb led light outdoor

pag. 88

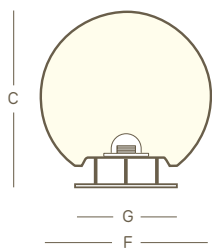

Art. 2761
ø cm. 65

C cm. 70
F cm. 65
G cm. 34

Legenda / Legend



Lampada fluorescente MAX 1 x 60 W
Fluorescent lamp MAX 1 x 60 W



Classe di isolamento: Classe II.
Con doppio isolamento e/o rinforzo in ogni parte e senza dispositivi per la messa a terra.
Insulation class: Class II.
With double insulation and/or reinforcement in each part and without ground devices.



Classe di isolamento: Classe III
Con isolamento ridotto perchè destinato a essere esclusivamente alimentato da un sistema a bassissima tensione di sicurezza (minore o uguale a 48V dc) e nel quale si generano tensioni di valore superiore a quello di tale sistema.
Insulation class: Class III.
With reduced insulation because the device is destined to be powered exclusively by a safety extra-low voltage system (max. 48V DC or less) in which voltages of values higher than those of such system are generated.



Attesta la conformità del prodotto alle disposizioni delle direttive comunitarie.
It certifies the conformity of the product to the European community instructions.

IP 20

Prodotto di uso ordinario. Protetto contro corpi solidi di diametro superiore a 12,5mm. L'utente non ha comunque modo di entrare in contatto con le parti in tensione. Prodotto con nessuna protezione nei confronti della penetrazione dell'acqua.
Product for ordinary use, protected against solid objects larger than 12.5 mm in diameter. Users cannot however come into contact with the live parts. This product has no water protection.

IP 67

Totalmente protetto contro la penetrazione di polveri. Prodotto resistente all'immersione temporanea massimo ad 1m di profondità. L'icona, dove presente, fa riferimento al corpo lampada.
Totally protected against penetration of dust. Product resistant against temporary immersion in water to a maximum of 1 m depth. Wherever present, the icon refers to the lamp's casing.

IP 68

Totalmente protetto contro la penetrazione di polveri. Prodotto resistente alla sommersione permanente in acqua. L'icona, dove presente, fa riferimento al corpo lampada.
Totally protected against penetration of dust. Product resistant against permanent immersion in water. Wherever present, the icon refers to the lamp's casing.



Ai sensi della Direttiva 2012/19/UE, il prodotto, alla fine della sua vita utile, non deve essere smaltito come rifiuto urbano.
According to the Directive 2012/19/UE, once the device life time is ended, it must not be disposed as urban waste.

Tutte le apparecchiature elettriche sono conformi alle direttive 2011/65/UE sulle Restrizioni d'uso di alcune sostanze pericolose (RoHS), recepite in Italia con il D.lgs 04/03/2014 n.27.

All electric equipments meet the Directives 2011/65/UE about the Reduction of the use of certain Hazardous Substances (RoHS), which came into force in Italy with D. lgs 04/03/2014 n.27.

Avvertenze - Warning:

- Collegare la spina dell'apparecchio in una presa collocata in un luogo protetto dalla pioggia e dagli spruzzi d'acqua.
- Se il cavo flessibile esterno di questo apparecchio viene danneggiato, deve essere sostituito esclusivamente dal costruttore, dal suo servizio di assistenza, o da personale qualificato equivalente, al fine di evitare pericoli.
- Nelle versioni sprovviste di interruttore sul cavo di alimentazione, collegare la spina dell'apparecchio sotto una presa comandata da interruttore.
- Si sconsiglia l'utilizzo e/o l'installazione dei prodotti luminosi su superfici/pavimentazioni non solide (sabbia, terra, erba, sassi, ghiaia, ecc.).
Inoltre, i prodotti luminosi non dovranno essere installati in prossimità (adiacenti e sullo stesso piano) di piscine e/o ambienti d'acqua.

- Connect the plug of the appliance to a power outlet that is located in a sheltered position, protected from rain and water splashes.
- If the external flexible cable of this appliance is damaged it must be replaced by either the manufacturer, the manufacturer's customer assistance service or by equivalent qualified personnel, in order to prevent possible hazards.
- For models that are not equipped with an inline on/off switch, connect the plug of the appliance to a switch controlled outlet.
- The use and/or installation of illumination devices on instable surfaces/floors or pavement (sand, soil, grass, stones, gravel, etc.) is discouraged. Neither must illumination devices be installed near (adjacent to or on the same level as) swimming pools and/or other water environments

khilia mini lights

dati tecnici

technical data

mini ikon light

pag. 100

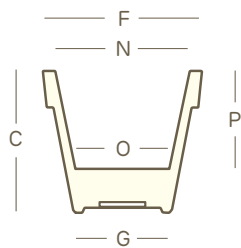

Art. 2782
 ø cm. 20

C cm. 17,5
 F cm. 20
 G cm. 11,5
 N cm. 16
 O cm. 11
 P cm. 12

mini kube light

pag. 102

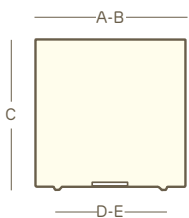

Art. 2784
 cm. 20

A-B cm. 20
 C cm. 20
 D-E cm. 15

mini kube light cassetta • plant box

pag. 104

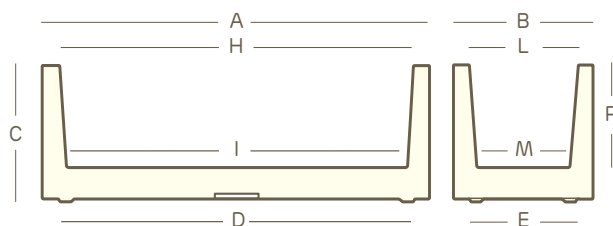

Art. 2791
 cm. 60

A cm. 60
 B cm. 20
 C cm. 20
 D cm. 55
 E cm. 14,5
 H cm. 55
 I cm. 52
 L cm. 15
 M cm. 13
 P cm. 15,5

mini kube light vaso • pot

pag. 101

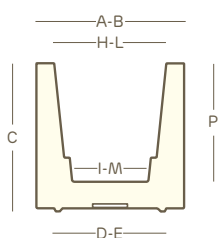

Art. 2783
 cm. 20

A-B cm. 20
 C cm. 20
 D-E cm. 15
 H-L cm. 15
 I-M cm. 12
 P cm. 14,5

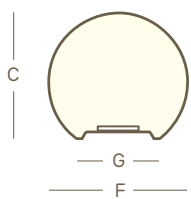

Art. 2636
cm. 20

C cm. 18
F cm. 20
G cm. 11,5

khilia kit luce per interni

pag. 106

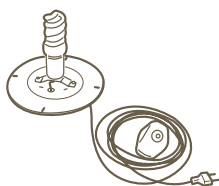

khilia kit luce in PC per **interni**
indoor PC khilia light kit

Il kit luce è compatibile con lampadine di classi energetiche E → A++, ed è venduto con una lampada di classe energetica A.

The light kit is compatible with bulbs of the energy class E → A++, and is sold with a bulb of the energy class A.

art. A4279

dettagli • details

piastra in policarbonato • polycarbonate plate
cavo trasparente • transparent cable
pulsantiera a pedale • foot switch
spina europea bipolare • european bipolar plug
lunghezza cavo • wire length: **cm. 370**

luce • light
1 x 20 W



khilia kit luce per esterni

pag. 107

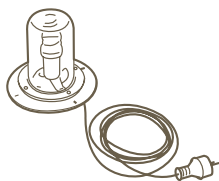

khilia kit luce in PC per **esterni**
outdoor PC khilia light kit

Il kit luce è compatibile con lampadine di classi energetiche E → A++, ed è venduto con una lampada di classe energetica A.

The light kit is compatible with bulbs of the energy class E → A++, and is sold with a bulb of the energy class A.

art. A4280

dettagli • details

piastra in policarbonato • polycarbonate plate
guscio in policarbonato • polycarbonate shell
guarnizione a tenuta • gasket seal
cavo nero • black cable
spina schuko antispruzzo • anti-splash
lunghezza cavo • wire length: **cm. 280**

luce • light
1 x 20 W



kit led rgb per interni/esterni

pag. 108

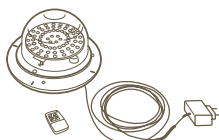

kit led rgb per **interni/esterni**
rgb led light kit **indoor/outdoor**

Il kit luce è munito di lampade a LED integrate con classe energetica A→A++.

The light kit is equipped with integrated LED bulbs of the energy class A → A++.

art. A4307

dettagli • details

guscio in policarbonato • polycarbonate shell
telecomando • remote control
cavo nero • black cable
spina europea bipolare • european bipolar plug
trasformatore in 12V a parete • 12V wall transformer
predisposizione per base di stabilizzazione
arrangement for stability base
lunghezza cavo • wire length: **cm. 500**

luce • light
modulo 60 led rgb 15W
15W 60 led rgb module



kit led rgb a batteria con spina per interni/esterni

pag. 110

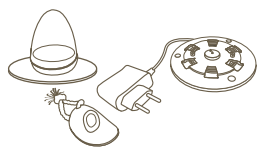

kit led rgb a batteria con spina per
interni/esterni

rgb led light kit with battery with plug
indoor/outdoor

art. A4364

dettagli • details

kit led rgb powered by smart&green
autonomia 6 ore circa alla massima intensità
autonomy 6 hours on average at maximum power
telecomando • remote control
base di ricarica con spina europea bipolare
european bipolar plug charger
diffusore in polietilene resistente ai raggi u.v. e agli urti
polyethylene plastic diffuser, resistant to u.v. and shocks
batteria li-ion polimeri 3,7V 2200 mAh • battery li-ion
3,7V 2200 mAh

luce • light

35 led: 20 led bianchi e 15 led colorati - 1,2 W
35 leds: 20 white leds and 15 color leds - 1,2 W



kit mini led light per interni

pag. 112

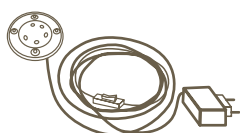

kit mini led light per **interni**
mini led light kit **indoor**

Il kit luce è munito di lampade a LED
integrate con classe energetica A → A++.

The light kit is equipped with integrated LED
bulbs of the energy class A → A++.

art. A4303

dettagli • details

cavo trasparente • transparent cable
spina europea bipolare • european bipolar plug
trasformatore in 12V a parete • 12V wall transformer
pulsantiera • switch
lunghezza cavo • wire length: cm. 140

luce • light

modulo 6 led bianchi 1,5 W
1,5 W white 6 led module



khilia riserva d'acqua

dati tecnici

technical data

rotonde • round

kit riserva d'acqua ø 20

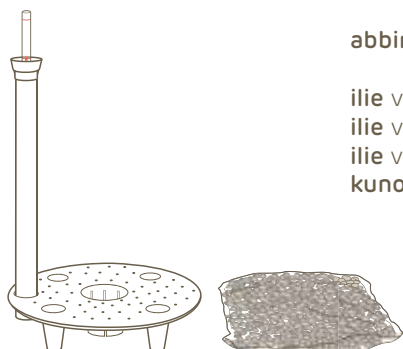

kit riserva d'acqua ø 20
water reserve kit ø 20

abbinato a • fitting to:

ilie vaso ø cm. 37
ilie vaso gloss ø cm. 37
ilie vaso laccato ø cm. 37
kuno vaso gloss ø cm. 40

art. A4256

dettagli • details

griglia • separator: ø cm. 20
tubo con indicatore livello acqua • supply shaft with water level gauge: h. cm. 40
argilla espansa • expanded clay: lt. 1
capacità riserva acqua • water reserve capacity: lt. 1,3

07
nero
black
schwarz
negro
noir

kit riserva d'acqua ø 25

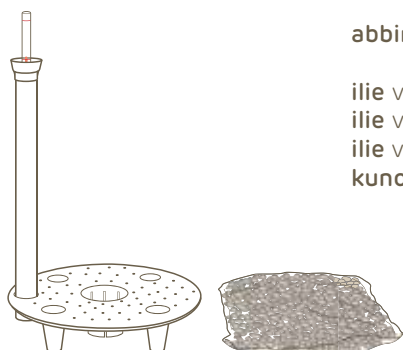

kit riserva d'acqua ø 25
water reserve kit ø 25

abbinato a • fitting to:

ilie vaso ø cm. 47
ilie vaso gloss ø cm. 47
ilie vaso laccato ø cm. 47
kuno vaso gloss ø cm. 50

art. A4239

dettagli • details

griglia • separator: ø cm. 25
tubo con indicatore livello acqua • supply shaft with water level gauge: h. cm. 47,5
argilla espansa • expanded clay: lt. 2
capacità riserva acqua • water reserve capacity: lt. 2,5

07
nero
black
schwarz
negro
noir

kit riserva d'acqua ø 32

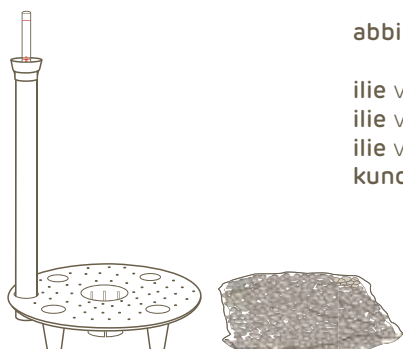

kit riserva d'acqua ø 32
water reserve kit ø 32

abbinato a • fitting to:

ilie vaso ø cm. 57
ilie vaso gloss ø cm. 57
ilie vaso laccato ø cm. 57
kuno vaso gloss ø cm. 60

art. A4240

dettagli • details

griglia • separator: ø cm. 32
tubo con indicatore livello acqua • supply shaft with water level gauge: h. cm. 57,5
argilla espansa • expanded clay: lt. 3
capacità riserva acqua • water reserve capacity: lt. 4

07
nero
black
schwarz
negro
noir

quadrate • square

kit riserva d'acqua cm. 17

kit riserva d'acqua cm. 17
water reserve kit cm. 17

art. A4255

abbinato a • fitting to:

dettagli • details

kiam vaso gloss cm. 30
kuba vaso cm. 30
kuba vaso cm. 30 con ruote
kuba vaso gloss cm. 30
kuba vaso gloss cm. 30 con ruote
kuba high vaso cm. 30
kuba high vaso cm. 30 con ruote
kuba high slim vaso cm. 25
kuba tower vaso cm. 30

griglia • separator: cm. 17 x 17
tubo con indicatore livello acqua • supply shaft with water level gauge: h. cm. 33,5
argilla espansa • expanded clay: lt. 1
capacità riserva acqua • water reserve capacity: lt. 1,2

07

nero
black
schwarz
negro
noir

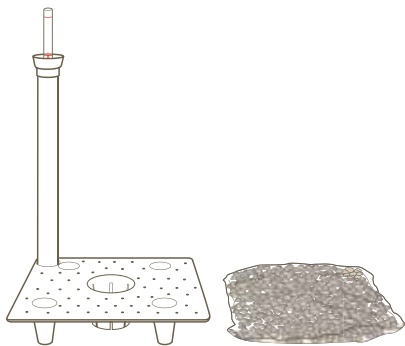

kit riserva d'acqua cm. 17

kit riserva d'acqua cm. 17
water reserve kit cm. 17

art. A4373

abbinato a • fitting to:

dettagli • details

kiam vaso gloss cm. 35

griglia • separator: cm. 17 x 17
tubo con indicatore livello acqua • supply shaft with water level gauge: h. cm. 38
argilla espansa • expanded clay: lt. 1
capacità riserva acqua • water reserve capacity: lt. 1,2

07

nero
black
schwarz
negro
noir

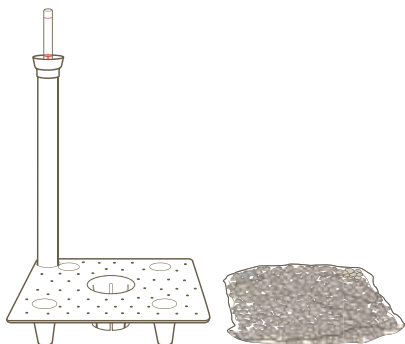

kit riserva d'acqua cm. 24

kit riserva d'acqua cm. 24
water reserve kit cm. 24

art. A4241

abbinato a • fitting to:

dettagli • details

kiam vaso gloss cm. 40
kuba vaso cm. 40
kuba vaso cm. 40 con ruote
kuba vaso gloss cm. 40
kuba vaso gloss cm. 40 con ruote
kuba high vaso cm. 40
kuba high vaso cm. 40 con ruote

griglia • separator: cm. 24 x 24
tubo con indicatore livello acqua • supply shaft with water level gauge: h. cm. 40
argilla espansa • expanded clay: lt. 2
capacità riserva acqua • water reserve capacity: lt. 3

07

nero
black
schwarz
negro
noir

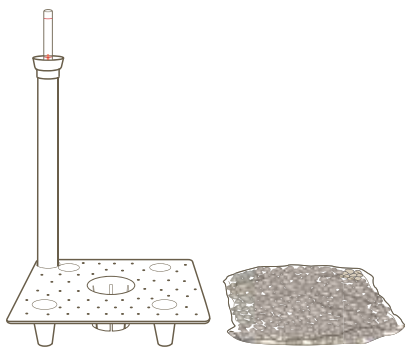

kit riserva d'acqua cm. 30

kit riserva d'acqua cm. 30
water reserve kit cm. 30

art. A4242

abbinato a • fitting to:

dettagli • details

kube vaso cm. 50
kube vaso cm. 50 con ruote
kube vaso gloss cm. 50
kube vaso gloss cm. 50 con ruote

griglia • separator: cm. 30x30
tubo con indicatore livello acqua • supply shaft
with water level gauge: h. cm. 48,5
argilla espansa • expanded clay: lt. 3
capacità riserva acqua • water reserve capacity: lt. 5

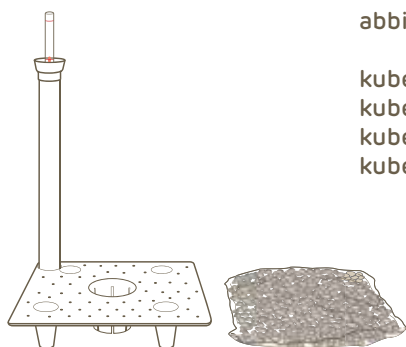

nero
black
schwarz
negro
noir

07

cassette • plant boxes

kit riserva d'acqua cm. 17 x 51

kit riserva d'acqua cm. 17x51
water reserve kit cm. 17x51

art. A4327

abbinato a • fitting to:

dettagli • details

kube cassetta cm. 80
kube cassetta cm. 80 con ruote
kube high cassetta cm. 80
kube high cassetta cm. 80 con ruote
kube high slim cassetta cm. 80
kube tower cassetta cm. 70

griglia • separator: 3 x cm. 17 x 17
tubo con indicatore livello acqua • supply shaft with water level gauge: h. cm. 33,5
argilla espansa • expanded clay: 3 x lt. 1
capacità riserva acqua • water reserve capacity: lt. 3,6

nero
black
schwarz
negro
noir

07

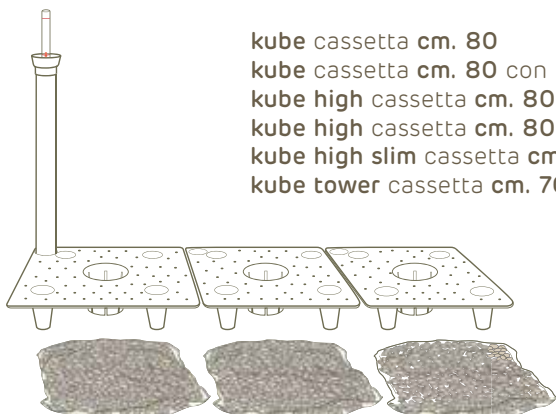

kit riserva d'acqua cm. 24 x 72

kit riserva d'acqua cm. 24x72
water reserve kit cm. 24x72

art. A4278

abbinato a • fitting to:

dettagli • details

kube cassetta cm. 100
kube cassetta cm. 100 con ruote
kube high cassetta cm. 100
kube high cassetta cm. 100 con ruote

griglia • separator: 3 x cm. 24 x 24
tubo con indicatore livello acqua • supply shaft with water level gauge: h. cm. 40
argilla espansa • expanded clay: 3 x lt. 2
capacità riserva acqua • water reserve capacity: lt. 9

nero
black
schwarz
negro
noir

07

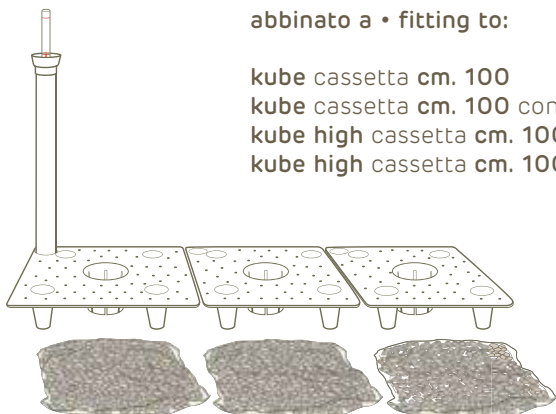

colors

collection

- C2** bianco
white
weiss
blanco
blanc
- G9** tortora
taupe
taupe
tortola
tourterelle
- B7** nero perla
pearl black
pearl schwarz
negro perla
noir perle
- 86** verde acido
acid green
apfel grün
verde acido
vert anis
- A2** verde A2
green A2
grün A2
verde A2
vert A2
- 43** verde smeraldo
emerald green
petrol
verde esmeralda
vert emeraude
- A9** rosso
red
rot
rojo
rouge
- D7** rosso oriente
orient red
orientrot
rojo oriente
rouge orient
- E5** ruggine
rust
rost
oxido
rouille
- C1** arancio
orange
orange
naranja
orange

gloss

- C2** bianco
white
weiss
blanco
blanc
- E5** ruggine
rust
rost
oxido
rouille

light

- 98** neutro
neutral
neutral
transparente
neutre

laccati

- 03** bianco
white
weiss
blanco
blanc
- 07** nero
black
schwarz
negro
noir
- D7** rosso oriente
orient red
orientrot
rojo oriente
rouge orient



pastel colors

M9

sabbia
sandy
sand
arena
sable

N1

giada
jade
jade
jade
jade

N2

cenere
ashen
asche
ceniza
cendre

N0

cipria
powder
puder
polvo
poudre

69

avorio
ivory
elfenbein
marfil
ivoire



special colors



nero - verde
black - green
schwarz - grün
negro - verde
noir - vert



nero - arancio
black - orange
schwarz - orange
negro - naranja
noir - orange



cenere - bianco
ashen - white
asche - weiss
ceniza - blanco
cendre - blanc

ATTENZIONE: La stampa su carta non sempre riproduce fedelmente i colori dei prodotti.

Le immagini e i dati riportati in questo catalogo sono indicativi. **euro3plast spa** si riserva il diritto di apportare eventuali variazioni o migliorie agli articoli illustrati, anche senza preavviso. I nostri uffici commerciali rimangono a vostra completa disposizione per qualsiasi ulteriore delucidazione.

Tutto il materiale contenuto in questo catalogo, compresi i testi, le fotografie, i disegni, è proprietà di **euro3plast spa** e pertanto è protetto dalle leggi che tutelano la proprietà intellettuale. Per tale motivo non può essere utilizzato senza esplicita autorizzazione scritta da **euro3plast spa**.

ATTENTION: The print on the paper doesn't grant the accurate reproduction of the colors.

The images and the indicated data in our catalogue are approximate. **euro3plast spa** reserves the right to effect any changes or improvements, to the illustrated articles, also without notice. For further information, our Customer Service are at your disposal.

All the material in this catalogue (including texts, photos and drawing), belong to **euro3plast spa**. Therefore it is protected by laws defending intellectual property. For this reason it cannot be used by anybody without the prior and written authorization of **euro3plast spa**.

graphic design & art director
Euro3plast spa

photo
Lorenzo Ceretta
Riccardo Urnato



euro3plast spa • viale del lavoro, 45 • 36021 ponte di barbarano (vi) italy • t +39 0444 788200 • f +39 0444 788290
www.euro3plast.com • info@euro3plast.com

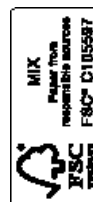

printed in italy - tipolitografia campisi (vi) 05/2017



8 000072 022186